

GEN2.4KW SERIES

Laboratory Power Supplies: 2.4KW



Features

- High Power Density 2.4KW in 1U
- Single phase 240VAC or 3phase 208VAC
- Power Factor Correction
- Output voltage up to 600V, current up to 300A
- Built-in RS232 / RS-485 Interface Standard
- Last Setting Memory: Front Panel Lockout
- Parallel Operation / Master Slave with up to four units
- Reliable Encoders for Voltage & Current adjustment
- Independent Remote ON/OFF and Remote Enable / Disable
- External Analog programming & Monitoring (0-5V or 0-10V)
- Auto Re-Start / Safe-Start: user selectable
- Optional Interfaces :
 - LX/ Compliant LAN
 - Isolated Analog Programming & Monitoring Interface
 - IEEE Multi-Drop –SCPI, USB interface
 - Labview & LabWindows drivers

Model Table Selection:

Model	Output		Power W
	V	A	
GEN8-300	0 – 8V	0 – 300A	2400W
GEN10-240	0 – 10V	0 – 240A	2400W
GEN16-150	0 – 16V	0 – 150A	2400W
GEN20-120	0 – 20V	0 – 120A	2400W
GEN30-80	0 – 30V	0 – 80A	2400W
GEN40-60	0 – 40V	0 – 60A	2400W

Model	Output		Power W
	V	A	
GEN60-40	0 – 60V	0 – 40A	2400W
GEN80-30	0 – 80V	0 – 30A	2400W
GEN100-24	0 – 100V	0 – 24A	2400W
GEN150-16	0 – 150V	0 – 16A	2400W
GEN300-8	0 – 300V	0 – 8A	2400W
GEN600-4	0 – 600V	0 – 4A	2400W

How to order:

GEN 10 240 - IEE - 1P230

Series Name	Output Voltage	Output Current	Options	AC Input Options
			IEEE	1P230 (170-265V)
			IS510	3P208 (170-265V)
			IS420	
			LAN	

Options:

1phase 240VAC (170-265) - **1P230**
3phase 208VAC (170-265) - **3P208**

RS232 / RS-485 Interface built-in (Standard)
 GPIB (Multi-Drop Master Interface) – **IEEE**
 Voltage Programming Isolated Analag Interface – **IS510**
 Current Programming Isolated Analog Interface - **IS420**
 LAN Interface (complies with LXI Class C) - **LAN**

GEN2.4KW SERIES

Laboratory Power Supplies: 2.4KW

Front Panel Description



1. ON/OFF Switch
2. Air Intake allows zero stacking for maximum system flexibility and power density.
3. Reliable encoder controls Output Voltage, Address, OVP and UVL settings.
4. Volt Display shows Output Voltage and directly displays OVP, UVL and Address settings.
5. Reliable encoder controls Output Current, sets baudrate and Advanced Parallel mode.
6. Current Display shows Output Current and displays Baud rate. Displays total current in Parallel Master/Slave Mode
7. Function/Status LEDs:

- Alarm
- Fine Control
- Preview Settings
- Foldback Mode
- Remote Mode
- Output On

8. Pushbuttons allow flexible user configuration

8. Pushbuttons allow flexible user configuration

- Coarse and Fine adjustment of Output Voltage/Current and Advanced Parallel Master or Slave select.
- Preview settings and set Voltage/Current with Output OFF, Front Panel Lock
- Parallel Master/Slave
- Set OVP and UVL Limits
- Set Current Foldback Protection
- Go to Local Mode and select Address and Baud rate
- Output ON/OFF and Auto-Re-Start/Safe-Start Mode

Rear Panel Description



1. Remote/Local Output Voltage Sense Connections.
2. DIP Switches select 0-5V or 0-10V Programming and other functions.
3. DB25 (Female) connector allows (Non-isolated) Analog Program and Monitor and other functions.
4. RS-485 OUT to other Genesys™ Power Supplies.
5. RS-232/RS-485 IN Remote Serial Programming.
6. Output Connections: Rugged busbars (shown) for up to 100V Output; wire clamp connector for Outputs >100V.
7. Exit air assures reliable operation when zero stacked.
8. Input: 230VAC Single Phase (shown), 208 VAC Three Phase, 50/60 Hz AC Input Connector: Phoenix P/N: FRONT-4-H-7.62.
9. Optional Interface Position for IEEE 488.2 SCPI (shown) or Isolated Analog Interface or LAN Interface.
10. Auxiliary Output Voltage Connector. Phoenix P/N: IMC1.5/7-ST-3.81

GEN2.4KW SERIES

Laboratory Power Supplies: 2.4KW

Genesys™ 2.4kW Specifications

1.0 MODEL Specifications in blue are improved

MODEL	GEN	8-300	10-240	16-150	20-120	30-80	40-60	60-40	80-30	100-24	150-16	300-8	600-4
1. Rated output voltage(*1)	V	8	10	16	20	30	40	60	80	100	150	300	600
2. Rated Output Current(*2)	A	300	240	150	120	80	60	40	30	24	16	8	4
3. Rated Output Power	W	2400	2400	2400	2400	2400	2400	2400	2400	2400	2400	2400	2400

1.1 CONSTANT VOLTAGE MODE

1. Max. line regulation (0.01% of rated Vo+2mV)(*6)	mV	2.8	3	3.5	4	5	6	8	10	12	17	32	62
2. Max load regulation (0.015% of rated Vo+5mV)(*7)	mV	6.2	6.5	7.25	8	9.5	11	14	17	20	27.5	50	95
3. Ripple and noise p-p 20MHz (*8)	mV	50	50	50	50	55	55	60	60	70	90	150	240
4. Ripple r.m.s 5Hz~1MHz	mV	6	6	6	6	6	6	6	7	10	20	45	60
5. Remote sense compensation/wire	V	2	2	2	2	5	5	5	5	5	5	5	5
6. Temp. coefficient	PPM/°C	50PPM/°C of rated output voltage, following 30 minutes warm-up											
7. Temp. stability		0.01% of rated Vout over 8hrs interval following 30 minutes warm-up. Constant line, load & temp.											
8. Warm-up drift		Less than 0.05% of rated output voltage+2mV over 30 minutes following power On.											
9. Up-prog. response time, 0~Vo Rated (*9)	mS	15											
10. Down-prog response time	Full-load (*9)	10	10	20	20	20	20	30	40	40	60	80	100
	No-load (*10)	500	500	500	500	600	700	1100	1200	1500	2500	3000	3000
11. Transient response time	mS	Time for output voltage to recover within 0.5% of its rated output for a load change 10-90% of rated output current. Output set-point: 10-100%, local sense. Less than 1mSec for models up to and including 100V. 2msec for models above 100V											

1.2 CONSTANT CURRENT MODE

1. Max. line regulation (0.01% of rated Io+2mA)(*6)	mA	32	26	17	14	10	8	6	5	4.4	3.6	2.8	2.4
2. Max. load regulation (0.02% of rated Io+5mA)(*11)	mA	65	53	35	29	21	17	13	11	9.8	8.2	6.6	5.8
3. Ripple r.m.s 5Hz~1MHz. (*12)	mA	700	500	400	250	150	90	60	40	30	12	10	5
4. Load regulation thermal drift		Less than 0.1% of rated output current over 30 minutes following load change.											
5. Temp. coefficient	PPM/°C	70PPM/°C from rated output current, following 30 minutes warm-up.											
6. Temp. stability		0.01% of rated Iout over 8hrs. interval following 30minutes warm-up. Constant line, load & temperature.											
7. Warm-up drift		8V~20V models: Less than ±0.5% of rated output current over 30 minutes following power On.											
		30V~600V models: Less than ±0.25% of rated output current over 30 minutes following power On.											

1.3 PROTECTIVE FUNCTIONS

1. OCP	0~105% Constant Current
2. OCP Foldback	Output shut down when power supply change from CV to CC. User selectable.
3. OVP type	Inverter shut-down, manual reset by AC input recycle or by OUT button or by communication port command.
4. OVP trip point	0.5~10V 0.5~12V 1~18V 1~24V 2~36V 2~44V 5~66V 5~88V 5~110V 5~165V 5~330V 5~660V
5. Output Under Voltage Limit	Preset by front panel or communication port. Prevents from adjusting Vout below limit.
6. Over Temp. Protection	User selectable, latched or non-latched.

1.4 ANALOG PROGRAMMING AND MONITORING

1. Vout Voltage Programming	0~100%, 0~5V or 0~10V, user select. Accuracy and linearity: ±0.5% of rated Vout.
2. Iout Voltage Programming (*13)	0~100%, 0~5V or 0~10V, user select. Accuracy and linearity: ±1% of rated Iout.
3. Vout Resistor Programming	0~100%, 0~5/10Kohm full scale, user select. Accuracy and linearity: ±1% of rated Vout.
4. Iout Resistor Programming (*13)	0~100%, 0~5/10Kohm full scale, user select. Accuracy and linearity: ±1.5% of rated Iout.
5. On/Off control (rear panel)	By electrical. Voltage: 0~0.6V/2~15V, or dry contact, user selectable logic.
6. Output Current monitor (*13)	0~5V or 0~10V, Accuracy: ±1%, user selectable.
7. Output Voltage monitor	0~5V or 0~10V, Accuracy: ±1%, user selectable.
8. Power Supply OK signal	TTL high (4~5V) -OK, 0V-Fail 500ohm series resistance.
9. CV/CC Indicator	Open collector, CC mode: On, CV mode: Off, Maximum voltage: 30V, maximum sink current: 10mA
10. Enable/Disable	Dry contact. Open: off, Short: on. Max. voltage at Enable/Disable in: 6V.
11. Local/Remote analog control	By electrical signal or Open/Short: 0~0.6V or short: Remote, 2~15V or open: Local.
12. Local/Remote analog control Indicator	Open collector, Local: Off, Remote: On. Maximum voltage: 30V, maximum sink current: 10mA.

1.5 FRONT PANEL

1. Control functions	Vout/ Iout manual adjust by separate encoders (coarse and fine adjustment selectable).
	OVP/UVL manual adjust by Volt. Adjust encoder.
2. Display	On/Off, Output on/off, Re-start modes (auto, safe), Foldback control (CV to CC), Go to local control.
	Address selection by Voltage (or current) adjust encoder. Number of addresses: 31.
	Re-start modes (automatic restart, safe mode).
	Baud rate selection: 1200, 2400, 4800, 9600 and 19,200.
3. Indications	Voltage: 4 digits, Accuracy: 0.05% of rated output Voltage ±1 count.
	Current: 4 digits, Accuracy: 0.2% of rated output current ±1 count.
	Voltage, Current, Alarm, Fine, Preview, Foldback, Local, Output On, Front Panel Lock, CVCC.

1.6 Interface Specifications for the GENESYS Series with RS-232/RS-485 Or Optional GPIB/LAN Interface Installed

1. Remote Voltage Programming (16 bit)	V	8	10	15	20	30	40	60	80	100	150	300	600
Resolution (0.002% of Vo Rated)	mV	0.16	0.2	0.3	0.4	0.6	0.8	1.2	1.6	2	3	6	12
Accuracy (0.05% of Vo Rated) (*14)	mV	4	5	8	10	15	20	30	40	50	75	150	300
2. Remote Current Programming (16 bit)	mA	6	4.80	3.00	2.40	1.60	1.20	0.80	0.60	0.48	0.32	0.16	0.08
Resolution (0.002% of Io Rated)	mA	900	720	450	360	240	180	120	90	72	48	24	12
Accuracy (0.2% of Io Rated+0.1% of Io Actual Output) (*13)	mA	900	720	450	360	240	180	120	90	72	48	24	12
3. Readback Voltage	%	0.002	0.011	0.007	0.006	0.004	0.003	0.002	0.002	0.011	0.007	0.004	0.002
Resolution (% of Vo Rated)	mV	0.16	1.10	1.05	1.20	1.20	1.20	1.20	1.60	11.00	10.50	12.00	12.00
Resolution (Readback Voltage)	mV	4	5	8	10	15	20	30	40	50	75	150	300
Accuracy (0.05% of Vo Rated)													
4. Readback Current	%	0.004	0.005	0.007	0.009	0.002	0.002	0.003	0.004	0.005	0.007	0.002	0.003
Resolution (% of Io Rated)	mA	12	12	10.5	10.8	1.6	1.2	1.2	1.2	1.2	1.120	0.160	0.120
Resolution (Readback Current)	mA	900	720	450	360	240	180	120	90	72	48	24	12
Accuracy (0.3% of Io Rated) (*13)													
5. OVP/UVL Programming	mV	8	10	15	20	30	40	60	80	100	150	300	600
Resolution (0.1% of Vo Rated)	mV	80	100	150	200	300	400	600	800	1000	1500	3000	6000
Accuracy (1% of Vo Rated)													

*1: Minimum voltage is guaranteed to maximum 0.2% of rated output voltage.
 *2: Minimum current is guaranteed to maximum 0.4% of rated output current.
 *3: For cases where conformance to various safety standards (UL, IEC, etc.) is required, to be described as 190-240Vac (50/60Hz) for 3-Phase 208V models.
 *4: 3-Phase 208V models: At 208Vac input voltage. With rated output power.
 *5: Not including EMI filter inrush current, less than 0.2mSec.
 *6: 3-Phase 208V models: 170~265Vac, constant load.
 *7: From No-Load to Full-Load, constant input voltage. Maximum drop in Remote Sense.
 *8: For 8V~300V models: Measured with JEITA RC-9131A (1:1) probe. For 600V model: Measured
 *9: From 10% to 90% or 90% to 10% of Rated Output Voltage, with rated, resistive load with 10:1 probe.

*10: From 90% to 10% of Rated Output Voltage.
 *11: For load voltage change, equal to the unit voltage rating, constant input voltage.
 *12: For 8V~16V models the ripple is measured from 2V to rated output voltage and rated output current. For other models, the ripple is measured at 10~100% of rated output voltage and rated output current.
 *13: The Constant Current programming readback and monitoring accuracy does not include the warm-up and Load regulation thermal drift.
 *14: Measured at the sensing point.

GEN2.4KW SERIES

Laboratory Power Supplies: 2.4KW

General Specifications Genesys™ 2.4kW

2.1 INPUT CHARACTERISTICS		GEN	8-300	10-240	16-150	20-120	30-80	40-60	60-40	80-30	100-24	150-16	300-8	600-4
1. Input voltage/freq. (*3)		VAC	Single Phase,230V models: 170~265Vac, 47~63Hz 3-Phase, 208V models: 170~265Vac, 47~63Hz											
2. Maximum Input current at 100% load	Single Phase,230V models: 3-Phase, 208V models:	A	17.3	17.3	17.3	16.8	16.6	16.6	16.6	16.6	16.6	16.6	16.6	16.6
3. Power Factor (Typ)			10.5	10.5	10.5	10.2	10.1	10.1	10.1	10.1	10.1	10.1	10.1	10.1
4. Efficiency (*4)		%	84	84	86	86	86	88	88	88	88	88	88	87
5. Inrush Current (*5)		A	Single-Phase and 3-Phase 208V models: Less than 50A											
2.2 POWER SUPPLY CONFIGURATION														
1. Parallel Operation	Up to 4 identical units in master/slave mode													
2. Series Operation	Up to 2 identical units. with external diodes. 600V Max to Chassis ground													
2.3 ENVIRONMENTAL CONDITIONS														
1. Operating temp	0~50°C, 100% load.													
2. Storage temp	-20~85°C													
3. Operating humidity	20~90% RH (non-condensing).													
4. Storage humidity	10~95% RH (non-condensing).													
5. Vibration	MIL-810F, method 514.5 , The EUT is fixed to the vibrating surface.													
6. Shock	Less than 20G , half sine , 11mSec. Unit is unpacked.													
7. Altitude	Operating: 10000ft (3000m), Derate output current by 2%/100m above 2000m, Alternatively, derate maximum ambient temp. by 1°C/100m above 2000m. Non operating: 40000ft (12000m).													
8. RoHS Compliance	Complies with the requirements of RoHS directive.													
2.4 EMC														
1. Applicable Standards:														
2. ESD	IEC1000-4-2. Air-disch.-8KV, contact disch.-4KV													
3. Fast transients	IEC1000-4-4. 2KV													
4. Surge immunity	IEC1000-4-5. 1KV line to line, 2KV line to ground													
5. Conducted immunity	IEC1000-4-6, 3V													
6. Radiated immunity	IEC1000-4-3, 3V/m													
7. Magnetic field immunity	EN61000-4-8, 1A/m													
8. Voltage dips	EN61000-4-11													
9. Conducted emission	EN55022A, FCC part 15-A, VCCI-A.													
10. Radiated emission	EN55022A, FCC part 15-A, VCCI-A.													
2.5 SAFETY														
1. Applicable standards:	UL 60950-1, CSA 22.2 No. 60950-1, IEC 60950-1, EN 60950-1													
2. Interface classification	Models with Vout 50V: Output is SELV, all communication/control interfaces: RS232/485, IEEE, Isolated Analog, LAN, Sense, Remote Programming and Monitoring, 5V d.c. auxiliary output are SELV Models with 60V Vout 400V: Output is Hazardous, communication/control interfaces: RS232/485, IEEE, Isolated Analog, LAN, Remote Programming and Monitoring (pins 1-3, pins 14-16), 5V d.c. auxiliary output are SELV, Sense, Remote Programming and Monitoring (pins 8-13, pins 21-25), 15V auxiliary output are Hazardous. Models with 400V Vout 600V: Output is Hazardous, all communication/control interfaces-RS232/485, IEEE, Isolated Analog, LAN, Sense, Remote Programming and Monitoring (all pins), 5V d.c./15V d.c. auxiliary outputs are Hazardous.													
3. Withstand voltage	Vout 50V models: Input-Output/communication/control/auxiliary outputs (SELV): 4242VDC 1min, Input-Ground: 2828VDC 1min., Output/communication/control/auxiliary outputs (SELV)-Ground: 1000VDC 1min. 60V Vout 100V models: Input-Output/15V d.c. auxiliary output/communication/control (Hazardous): 2600VDC 1min, Input-communication/control/5V d.c. auxiliary output (SELV): 4242VDC 1min, Output/15V d.c. auxiliary output/communication/control (Hazardous): -communication/control/5V d.c. auxiliary output (SELV): 1900VDC 1min, Output/15V d.c. auxiliary output/communication/control (Hazardous): -Ground: 1200VDC 1min, Input-Ground: 2828VDC 1min. 100V Vout 600V models: Input-Output/15V d.c. auxiliary output/communication/control (Hazardous): 4000VDC 1min, Input-communication/control/5V d.c. auxiliary output (SELV): 4242VDC 1min, Output/15V d.c. auxiliary output/communication/control (Hazardous): -communication/control/5V d.c. auxiliary output (SELV): 3550VDC 1min, Output/15V d.c. auxiliary output/communication/control (Hazardous): -Ground: 2670VDC 1min, Input-Ground: 2828VDC 1min.													
3. Insulation resistance	More than 100Mohm at 25°C , 70% RH.													
2.6 MECHANICAL CONSTRUCTION														
1. Cooling	Forced air flow: from front to rear. No ventilation holes at the top or bottom of the chassis; Variable fan speed.													
2. Dimensions (WxHxD)	W: 423mm, H: 43.6mm, D: 441mm (excluding connectors, encoders, handles, etc.)													
3. Weight	Less than 10 kg.													
4. AC Input connector (with Protective Cover)	Single Phase,230V models, Power Combicon PC 6-16/3-GF-10,16 series, with Strain relief. 3-Phase, 208V & 400V models, Power Combicon PC 6-16/4-GF-10,16 series, with Strain relief.													
5. Output connectors	8V to 100V models: Bus-bars (hole Ø 10.5mm). 150V to 600V models: wire clamp connector, Phoenix P/N: FRONT-4-H-7.62													
2.7 AUXILIARY OUTPUTS														
1. 15V Output (*8)	15V± 5%, 0.2A Max Load, Ripple & Noise 100mVp-p. referenced internally to the negative output potential.													
2. 5V Output	5V± 5%, 0.2A Max Load, Ripple & Noise 100mVp-p. referenced internally to IF_COM potential.													
2.8 RELIABILITY SPECS														
1. Warranty	5 years.													

All specifications subject to change without notice.

GEN2.4KW SERIES

Laboratory Power Supplies: 2.4KW

Outline Drawing Genesys™ 2.4kW Units

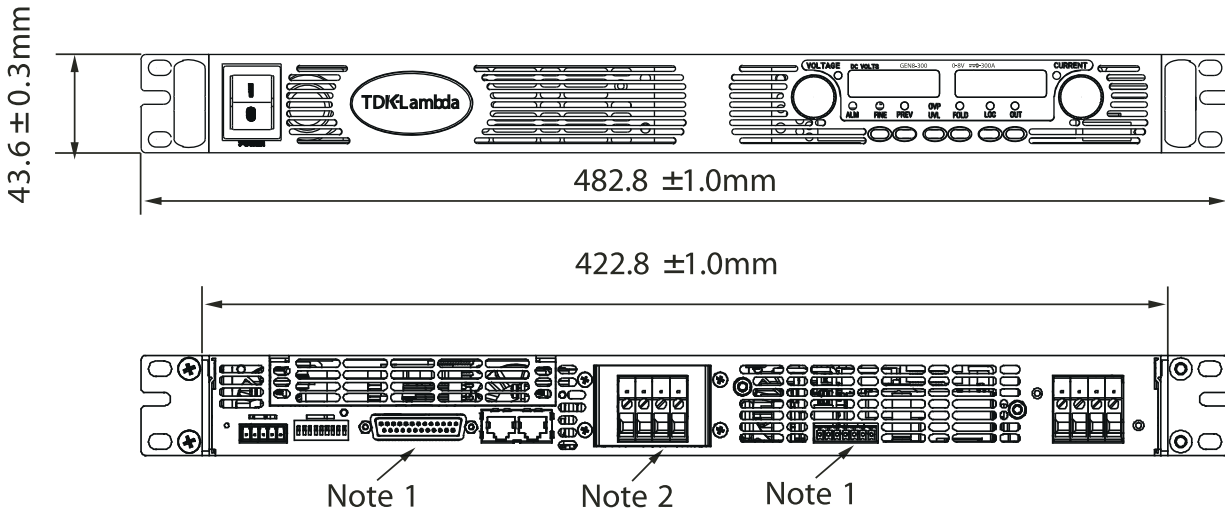

GEN2.4KW SERIES

Laboratory Power Supplies: 2.4KW

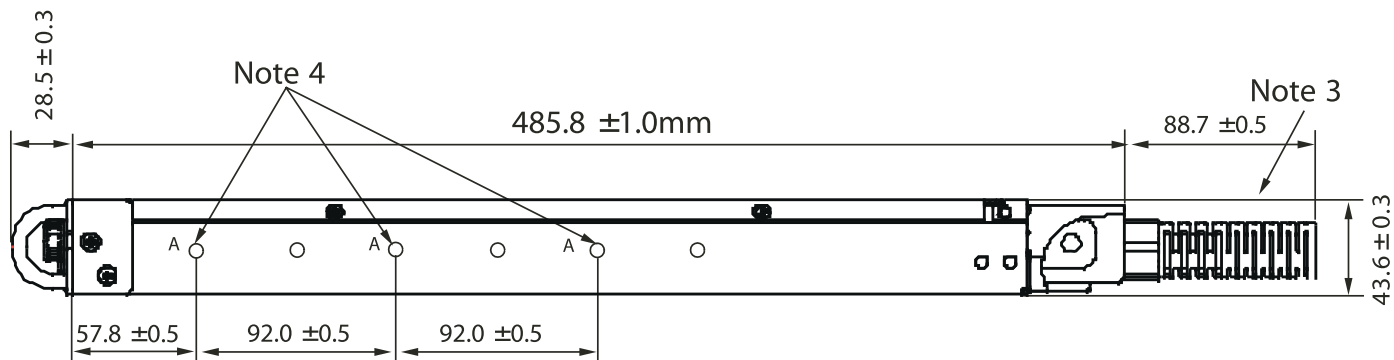

NOTE

1. Mating plug supplied with power supply.
2. Bus bars for 8V to 100V models. See Detail
2. Ac cable strain relief supplied with power supply.
4. Chassis slides mounting holes #10-32 marked "A".
GENERAL DEVICES P/N: CC3001-00-5160 or equivalent.

Genesys™ Power Parallel and Series Configurations

Parallel operation - Master/Slave:

Active current sharing allows up to four identical units to be connected in an auto-parallel configuration for four times the output power.

In Advanced Parallel Master/Slave Mode, total current is programmed and reported by the Master, Up to four supplies act as one.



Series operation

Up to two units may be connected in series to increase the output voltage or to provide bipolar output. (Max 600V to Chassis Ground).

Remote Programming via RS-232 & RS-485 Interface

Standard Serial Interface allows daisy-chain control of up to 31 power supplies on the same communication bus with built-in RS-232 & RS-485 Interface.

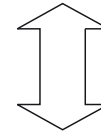
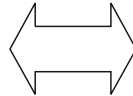

Programming Options (Factory installed)

Digital Programming via IEEE Multi-Drop Interface

P/N: IEEE

- Allows IEEE Master to control up to 30 slaves over RS-485 daisy-chain
- Only the Master needs be equipped with IEEE Interface
- IEEE 488.2 SCPI Compliant
- Program Voltage
- Measure Voltage
- Over Voltage setting and shutdown
- Error and Status Messages

- Program Current
- Measure Current
- Current Foldback shutdown

Isolated Analog Programming

Four Channels to Program and Monitor Voltage and Current.

Isolation allows operation with floating references in harsh electrical environments.

Choose between programming with Voltage or Current.

Connection via removable terminal block: Phoenix MC1,5/8-ST-3.81.

- Voltage Programming, user-selectable 0-5V or 0-10V signal.
Power supply Voltage and Current Programming Accuracy $\pm 1\%$
Power supply Voltage and Current Monitoring Accuracy $\pm 1.5\%$
- Current Programming with 4-20mA signal.
Power supply Voltage and Current Programming Accuracy $\pm 1\%$
Power supply Voltage and Current Monitoring Accuracy $\pm 1.5\%$

P/N: IS510

P/N: IS420

LAN Interface LXI Compliant to Class C

P/N: LAN

- Meets all LXI-C Requirements
- Address Viewable on Front Panel
- Fixed and Dynamic Addressing
- Compatible with most standard Networks
- VISA & SCPI Compatible
- LAN Fault Indicators
- Auto-detects LAN Cross-over Cable
- Fast Startup

Power Supply Identification / Accessories

How to order

GEN	8	-	300	-	-
Series Name	Output Voltage (0~8V)	Output Current (0~300A)	Factory Options: Option: IEEE IS510 IS420 LAN	Factory AC Input Options: 1P230 (Single Phase 170~265VAC) 3P208 (Three Phase 170~265VAC)	

Models 2.4kW

Model	Output Voltage VDC	Output Current (A)	Output Power (W)
GEN 8-300	0~8V	0~300	2400
GEN 10-240	0~10V	0~240	2400
GEN 16-150	0~16V	0~150	2400
GEN 20-120	0~20V	0~120	2400
GEN 30-80	0~30V	0~80	2400
GEN 40-60	0~40V	0~60	2400

Model	Output Voltage VDC	Output Current (A)	Output Power (W)
GEN 60-40	0~60V	0~40	2400
GEN 80-30	0~80V	0~30	2400
GEN 100-24	0~100V	0~24	2400
GEN 150-16	0~150V	0~16	2400
GEN 300-8	0~300V	0~8	2400
GEN 600-4	0~600V	0~4	2400

Factory option	P/N
RS-232/RS-485 Interface built-in Standard	-
GPIB Interface	IEEE
Voltage Programming Isolated Analog Interface	IS510
Current Programming Isolated Analog Interface	IS420
LAN Interface (Complies with LXI Class C)	LAN

Accessories

1. Serial Communication cable

RS-232/RS-485 cable is used to connect the power supply to the Host PC.

Mode	RS-485	RS-232	RS-232
PC Connector	DB-9F	DB-9F	DB-25F
Communication Cable	Shield Ground L=2m	Shield Ground L=2m	Shield Ground L=2m
Power Supply Connector	EIA/TIA-568A (RJ-45)	EIA/TIA-568A (RJ-45)	EIA/TIA-568A (RJ-45)
P/N	GEN/485-9	GEN/232-9	GEN/232-25

2. Serial link cable*

Daisy-chain up to 31 Genesys™ power supplies.

Mode	Power Supply Connector	Communication Cable	P/N
RS-485	EIA/TIA-568A (RJ-45)	Shield Ground L=50cm	GEN/RJ45

* Included with power supply



Also available, Genesys™
1U Half Rack 750W
1U full Rack
750W/1500W/2400W
2U full Rack 3300W/5000W