

400TR AND 800TR

TEST RODS

APPLICATION

- The test rod can be used for:
 - cable fault location
 - cable testing
 - phasing checks, etc.
- Connections may be made with a cable lug, a 4 mm plug or spring clips.

TECHNICAL CHARACTERISTICS

- The 400TR test rod can be used with 430TB connectors.
- The 800TR is for use with the 480TB, 484TB and 489TB.



DESIGN

1. Insulating shroud.
2. Threaded rod for test connection.
3. Two nuts M12.
4. Insulation.
5. Copper test rod stem.

An insulating shroud is provided to allow the application of test voltages when bushings are closely spaced.

INSTALLATION

The test rod is mounted on to the clamping screw in the type C interface tee and coupling connectors. The test cable is connected to the threaded stem and the insulating shroud moved to its final position over the end of the test rod.

ORDERING INSTRUCTIONS

Simply specify:
400TR or 800TR test rod.

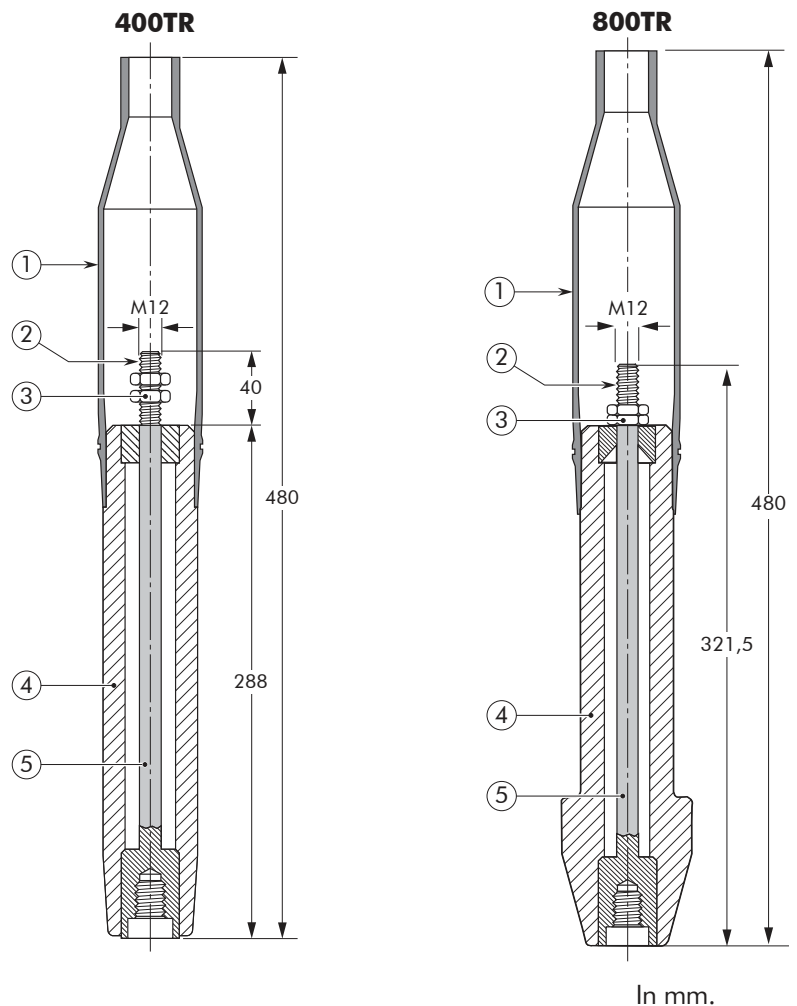

Test rod type	Maximum A.C. test voltage (50 Hz - 1 min)	Maximum D.C. test voltage (8 x U ₀ - 30 min)	Impulse voltage (1.2 x 50 μs)
400TR	36 kV	96 kV	95 kV
800TR	36 kV	96 kV	95 kV

05/2017