



# HVA28TD

## User Manual

**ENGLISH**

Rev 1.1

**HV Diagnostics, Inc.**  
North and South America

271 Rope Mill Pkwy, Ste 2  
Woodstock, GA 30189  
USA

Tel. +1 (678) 445 2555  
Fax +1 (678) 445 2557

[www.hvdiagnostics.com](http://www.hvdiagnostics.com)

**HV Diagnostic Sarl**  
Africa, Asia, Australia,  
Middle East

[www.hvdsa.com](http://www.hvdsa.com)



**Ultra-compact and universal  
VLF High Voltage Test Set  
with Tangent Delta**



## Table of Contents

|          |   |           |
|----------|---|-----------|
| <b>1</b> | <b><i>Forward</i></b> .....                 | <b>5</b>  |
| 1.1      | Regarding this Document .....               | 5         |
| 1.2      | Documentation Conventions .....             | 6         |
| 1.3      | Legal Considerations.....                   | 7         |
| <b>2</b> | <b><i>Safety</i></b> .....                  | <b>8</b>  |
| 2.1      | General Safety .....                        | 8         |
| 2.2      | Work Safety .....                           | 8         |
| 2.3      | Appropriate Applications .....              | 10        |
| 2.4      | Operator Qualifications .....               | 10        |
| <b>3</b> | <b><i>General Description</i></b> .....     | <b>11</b> |
| 3.1      | Technical Specifications.....               | 11        |
| 3.2      | Design Features .....                       | 12        |
| 3.3      | Materials .....                             | 13        |
| <b>4</b> | <b><i>Design and Construction</i></b> ..... | <b>15</b> |
| 4.1      | Control Elements .....                      | 15        |
| 4.2      | User Interface .....                        | 18        |
| 4.3      | Instrument Set-up .....                     | 20        |
| 4.4      | Operation Modes .....                       | 25        |
| <b>5</b> | <b><i>Test Procedure</i></b> .....          | <b>28</b> |
| 5.1      | Equipment Set-up.....                       | 28        |
| 5.2      | Manual Test Mode .....                      | 30        |
| 5.3      | Automatic Test Mode.....                    | 36        |
| 5.4      | Interrupting a Test.....                    | 43        |
| <b>6</b> | <b><i>Tangent Delta</i></b> .....           | <b>44</b> |
| 6.1      | Application .....                           | 44        |
| 6.2      | Equipment Set-up.....                       | 44        |
| 6.3      | Tangent Delta Test.....                     | 46        |
| 6.4      | PC Software HVA28TD .....                   | 49        |
| 6.5      | Bluetooth® Setup and Config Procedure ..... | 53        |
| <b>7</b> | <b><i>Reporting</i></b> .....               | <b>70</b> |



---

|           |  |           |
|-----------|--|-----------|
| <b>8</b>  | <b><i>Disconnection Procedure</i></b> .....    | <b>74</b> |
| <b>9</b>  | <b><i>Instrument Care</i></b> .....            | <b>76</b> |
| <b>10</b> | <b><i>Glossary and Abbreviations</i></b> ..... | <b>77</b> |
| <b>11</b> | <b><i>Declaration of Conformity</i></b> .....  | <b>78</b> |

# 1 Forward

## Purpose

This operating manual serves to ensure the proper and safe use of the HVA28TD test instrument.

## 1.1 Regarding this Document

### Target User

This operating manual is designed to inform various user groups. The scope and depth of the information provided may not be appropriate for all users. However, it is important that all users familiarize themselves with this document in full. The following is a guideline indicating the most significant information as a function of the user’s responsibilities.

| User                    | Responsibilities   | Focus   |
|-------------------------|--|---|
| HVA Operator            | <ul style="list-style-type: none"> <li>To connect the equipment</li> <li>To carry out manual or pre-programmed test sequence</li> <li>To verify validity of HVA application</li> <li>To adjust instrument settings</li> <li>To program automatic test sequences in accordance with particular testing standards</li> </ul> | <p><b>All Sections</b></p> <p>Particular focus on all <b>safety</b> messages</p>                                |
| Procurement, Management | <ul style="list-style-type: none"> <li>To assure that the workplace is safe and has all required equipment</li> <li>To assure that HVA operators are qualified technicians</li> <li>To assure that operators fulfil their responsibilities</li> </ul>  | <p>Particular focus on <b>safety</b> messages and information regarding <b>general</b> product description.</p> |

### Safekeeping



#### **NOTICE**

This manual should always be on hand when using the HVA28TD test instrument

## 1.2 Documentation Conventions

The following explain the **symbols**, and **safety messages** found in this document. The employment of safety symbols and signal words are according to the American National Standards Institute standard ANSI Z535.6 "Product Safety Signs and Labels".

### Safety Messages

#### Danger

**DANGER**

Indicates a hazardous situation which if not avoided will result in death or serious injury

#### Warning

**WARNING**

Indicates a hazardous situation which if not avoided could result in death or serious injury.

#### Caution

**CAUTION**

Indicates a hazardous situation which if not avoided could result in minor or moderate injury.

#### Notice

**NOTICE**

Indicates suggested practices to protect equipment and property.

### Symbols



Yellow triangle, framed in black: Used to indicate a potential hazard. Only used in conjunction with description of the possible hazard! Detailed symbol may correspond to this specific hazard.



Red outlined circle with red diagonal line: Used to indicate forbidden practices. The described handling practice must not be carried out!



Blue circle with white exclamation mark: Used to indicate recommended precautionary measures or a situation that can lead to property damage.

## 1.3 Legal Considerations

### Warranty

HV Diagnostics provides a one-year warranty from the original purchase date of instrument for all necessary parts and labor. This warranty is void in the event of abuse, incorrect operation or use, unauthorized modification or repairs, or failure to perform the specified maintenance as indicated in this operation manual. This warranty does not include normal consumable items such as lamps, paper rolls, printer ribbons, batteries or other auxiliary items.

This warranty and our liability are limited to replacing or repairing defective equipment at our discretion. Equipment that is returned to HV Diagnostics must be packed in original packaging. All shipped items must be prepaid and insured. No other warranties are expressed or implied.

### Contact Information

HV Diagnostics, Inc.  
271 Rope Mill Pkwy, Ste 2  
Woodstock, GA 30188  
USA  
T: +1 (678) 445 2555  
F: +1 (678) 445 2557  
North America  
[www.hvdiagnostics.com](http://www.hvdiagnostics.com)  
[sales@hvdiagnostics.com](mailto:sales@hvdiagnostics.com)

HV Diagnostic Sarl  
Africa, Asia, Australia,  
Middle East  
[www.hvdsa.com](http://www.hvdsa.com)

### Copyright

©2012 HV Diagnostics, Inc.  
All rights reserved.

No part of this publication may be reproduced, transmitted, stored, or translated in hardcopy or electronic form without the written consent of HV Diagnostics.

### Your opinion matters!

Your comments and suggestions are of value. We are dedicated to supporting your needs. Offering you optimal documentation is part of our promise of quality.

Improvement suggestions regarding this manual may be sent to:

[sales@hvdiagnostics.com](mailto:sales@hvdiagnostics.com)

Thank you for your feedback!

## 2 Safety

Safety is **priority!** Respect all **safety information**; only use the HVA28TD for **appropriate applications** and ensure that operators possess the required **operator qualifications**.

### 2.1 General Safety



#### NOTICE

##### Operation Manual

Before carrying out any high voltage test with this instrument, read this Operating Manual in its entirety.

### 2.2 Work Safety



#### DANGER

##### Electric Shock Hazard

Never assume that equipment is safe to handle without using the necessary safety equipment and grounding procedures.

- All procedures must comply with local safety regulations
- Always treat exposed connectors and conductors as potential electric shock hazards.
- DUT must be grounded, de-energized and isolated from all power sources.
- All auxiliary electrical apparatus such as switchgear, surge arresters etc. must be isolated from the test power source and the DUT.
- All cables and connectors must be inspected for damage before use. Damaged equipment must not be used.
- Ground connections must be made first and removed last!
- DUT must be discharged and grounded before disconnecting the test lead.
- Avoid testing alone. In the event of an emergency another person's presence may be essential.



#### DANGER

##### Authorized Personnel Only

The test area must be secured to keep non-qualified personnel off the premises!

- Signs must warn all persons of the high voltage test area.
- Only qualified electrical technicians should have access to the test area.
- Other persons must be accompanied by qualified electrical technicians and must be informed of the risks involved.





**WARNING**

**Radiation Hazard**

Testing vacuum bottles, above their voltage rating, with DC can produce dangerous X-rays.



**NOTICE**

**Equipment Handling**

DUT must have clean connections.  
Test instruments must only be repaired or modified by authorized HV Diagnostics personnel.



**NOTICE**

**If required according to local safety regulations**

Wear high voltage gloves when handling high voltage cables and equipment.

## 2.3 Appropriate Applications

The HVA28TD test instrument is designed to perform high voltage insulation testing of various types of highly capacitive loads.

### Appropriate DUTs

| DUT Type                      | Examples   |
|-------------------------------|--|
| Cables                        | <ul style="list-style-type: none"> <li>• Extruded cables (e.g. XLPE)</li> <li>• Laminated cables (e.g. PILC)</li> <li>• Insulated cables</li> <li>• Cable jacket / sheath</li> </ul> |
| Other highly capacitive loads | <ul style="list-style-type: none"> <li>• Generators</li> <li>• Switchgear</li> <li>• Transformers</li> <li>• Rotating machines</li> <li>• Insulators</li> <li>• Bushings</li> </ul>  |

### Appropriate Measurements

| Measurement | Examples  |
|-------------|---|
| Test        | <ul style="list-style-type: none"> <li>• Capacitance</li> <li>• Resistance</li> <li>• Dielectric breakdown voltage</li> <li>• RMS current</li> <li>• Applied voltage</li> </ul> |



### NOTICE

#### Other Applications

Before proceeding, contact HV Diagnostics to validate appropriate use!

## 2.4 Operator Qualifications

HVA operators must be **qualified electrical technicians!** Proof of necessary qualifications for working in high voltage domain is mandatory. It is highly recommended that operators have completed an emergency rescue training program.

## 3 General Description

### 3.1 Technical Specifications

| Characteristic                             | HVA28TD <sup>1</sup>  |
|--|---|
| Input Voltage                              | 100 – 240 V 50/60 Hz (400 VA)   |
| Output Voltage [Max.]                      | Sinusoidal: 0 – 28 kV peak, 20 kV rms<br>DC: ± 0 – 28 kV<br>Squarewave: 28 kV, Accuracy: ± 1%<br>Resolution: 0.1 kV   |
| Output Current                             | 0 – 20 mA (Resolution 1 µA) Accuracy: ± 1%  |
| Resistance Range                           | 0.1 MΩ....5 GΩ  |
| Output Frequency                           | 0.01 – 0.1 Hz in steps of 0.01 Hz (default 0.1 Hz) – auto frequency selection   |
| Output Load                                | 0.5 µF @ 0.1 Hz @ 20kV rms<br>5.0 µF @ 0.01 Hz @ 20 kV rms<br>10.0 µF maximum Capacitance! <sup>2</sup>   |
| Sheath Test                                | Max Test Voltage: 10 kV<br>Trip Current: 0.1 mA – 5.0 mA  |
| Sheath Fault Location <sup>3</sup>         | Max Test Voltage: 10 kV<br>Pulse/Period: 1:3 / 4 s, 1:5 / 4 s, 1:5 / 6 s, 1:9 / 6 s   |
| Test Modes                                 | AC (VLF) Symmetrical and load independent across full range, DC (plus or negative polarity), Burn-/ Fault Condition or Fault Trip Mode, Jacket / Sheath Testing |
| Safety                                     | 50 Hz – 12 kV Feedback Protection / Dual Discharge Device (internal)  |
| Record Storage                             | Built in Memory: up to 50 reports, 40 Test sequences<br>USB Memory Flash drive: Unlimited   |
| Metering                                   | Voltage and Current (True rms and / or peak),<br>Capacitance, Resistance, Time, Flashover Voltage   |
| Tangent Delta measurement optimal accuracy | ± 1 x 10 <sup>-4</sup>  |
| Duty                                       | Continuous! No thermal limitation for operating time  |
| PC Software [included]                     | “HVA Control Center” and “TD Control Center for Windows XP / Vista / 7  |
| Computer Interfaces                        | Bluetooth and USB   |
| Weight                                     | 14 kg / 31 lbs  |
| Dimensions [Peli Case 1430]                | 430mm x 240mm x 340mm / 17” x 9.5” x 13.4”  |
| Environment                                | Storage Temperature: -25°C to 70°C (-13°F to 158°F)<br>Operation Temperature: -5°C to 45°C (23°F to 113°F)<br>Humidity: 5-70 % non-condensing;                  |

<sup>1</sup> Technical Specifications are subject to change. HV Diagnostics reserves the right to modify values in accordance with future HVA28TD development.

<sup>2</sup> in combination with locating device (not in scope of supply)

<sup>3</sup> at lower frequency and voltage

## 3.2 Design Features







To assure that the workplace is safe and that operators can fulfil their responsibilities with ease, the HVA28TD provides the following features.

| Feature  | Purpose / Application  | Advantage  |
|--|--|--|
| Optimized Frequency Selection / Automatic load measurement | <ul style="list-style-type: none"> <li>To test capacitive loads</li> <li>No instrument restart necessary</li> </ul>                                    | <ul style="list-style-type: none"> <li>Facilitates testing</li> <li>Limits number of connections to the DUT</li> </ul>   |
| Fully Automatic Test Sequences                             | <ul style="list-style-type: none"> <li>To test according to IEEE and IEC, or other standards</li> </ul>  | <ul style="list-style-type: none"> <li>Facilitates complex testing</li> <li>Facilitates test repetition</li> </ul>   |
| Real Time Display  | <ul style="list-style-type: none"> <li>To indicate instantaneous output voltage display.</li> </ul>  | <ul style="list-style-type: none"> <li>Facilitates testing</li> </ul>  |
| Load independent output                                    | <ul style="list-style-type: none"> <li>To indicate true symmetrical sinusoidal and square wave waveforms output</li> </ul>                             | <ul style="list-style-type: none"> <li>Facilitates testing</li> </ul>  |
| Built in Memory  | <ul style="list-style-type: none"> <li>To save test sequences</li> <li>To save test reports</li> </ul>   | <ul style="list-style-type: none"> <li>Facilitates test repetition</li> <li>Facilitates documentation</li> </ul>   |
| Arc Management   | <ul style="list-style-type: none"> <li>To provide short-circuit protection</li> <li>To allow for fault conditioning</li> </ul>                         | <ul style="list-style-type: none"> <li>Limits test interruptions commonly encountered when using conventional HV test instruments that immediately trip on arc detection.</li> </ul> |
| Automatic load measurement                                 | <ul style="list-style-type: none"> <li>To limit connections to the DUT</li> </ul>  | <ul style="list-style-type: none"> <li>Facilitates testing</li> </ul>  |
| Intelligent Design   | <ul style="list-style-type: none"> <li>To avoid moving parts and need for lubrication</li> </ul>   | <ul style="list-style-type: none"> <li>Reduces maintenance</li> <li>Improves instrument durability and reliability</li> </ul>  |
| Instrument Lock-Key switch                                 | <ul style="list-style-type: none"> <li>To prevent against unauthorized use</li> </ul>  | <ul style="list-style-type: none"> <li>Improves safety</li> </ul>  |
| Local and remote emergency off switches                    | <ul style="list-style-type: none"> <li>To shutdown operations in emergency situation</li> </ul>  | <ul style="list-style-type: none"> <li>Improves safety</li> </ul>  |
| Fully integrated discharge and transient circuit           | <ul style="list-style-type: none"> <li>To ground the DUT after testing</li> <li>To protect the unit from transient over voltages</li> </ul>            | <ul style="list-style-type: none"> <li>Improves safety</li> <li>Protects instrument</li> </ul>   |
| Initial load clearance test at reduced voltages            | <ul style="list-style-type: none"> <li>To check automatically for shorts or grounds, during load measurement, before test initiation</li> </ul>        | <ul style="list-style-type: none"> <li>Improves safety</li> </ul>  |
| Return Voltage Indication                                  | <ul style="list-style-type: none"> <li>To monitor external high voltage greater than 100V (AC or DC )</li> </ul>                                       | <ul style="list-style-type: none"> <li>Improves safety</li> </ul>  |
| Discharge Status Indication                                | <ul style="list-style-type: none"> <li>To indicate when DUT is not fully discharged. LED Red lights when residual voltage greater than 100V</li> </ul> | <ul style="list-style-type: none"> <li>Improves safety during normal disconnection procedures</li> </ul>   |
| USB  | <ul style="list-style-type: none"> <li>To store test reports</li> <li>To upload test sequences</li> </ul>  | <ul style="list-style-type: none"> <li>Facilitates documentation</li> <li>Facilitates Test repetition</li> </ul>   |
| Bluetooth  | <ul style="list-style-type: none"> <li>To send test reports</li> <li>To upload test sequences</li> </ul>   | <ul style="list-style-type: none"> <li>Facilitates documentation</li> <li>Facilitates Test repetition</li> </ul>   |
| IP67 (with closed lid)                                     | <ul style="list-style-type: none"> <li>To avoid damage during transport or storage</li> <li>To protect instrument from water</li> </ul>                | <ul style="list-style-type: none"> <li>Protects instrument</li> <li>Improves functionality</li> </ul>  |

### 3.3 Materials

#### Shipment Content

Items included upon delivery of the HVA28TD are listed below. The \* marking specifies items that are country specific. For inquiries, please contact HV Diagnostics.

| Part No. | Item  | Description   | Qty |
|----------|---|---|-----|
| 702 003  | HVA28TD   |    | 1   |
| 702 502  | HVA28TD HV Cable  |    | 1   |
| 700 505  | Grounding Cable Transparent<br>6mm <sup>2</sup> / 4m; with 400A clamp         |   | 1   |
| 700 907  | Power On Key<br>Spare key for Key switch (7)                                  |  | 1   |
|          | Mains Cable*  |  | 1   |
| 702 509  | Connection External Guard –cable shield with<br>HVA28 Guard Connection DUT ** |  | 1   |
| 700 050  | Corona Shield 2 parts   |  | 2   |

| Part No. | Item   | Description  | Qty |
|----------|--|--|-----|
|          | HV Plug 50kV protection  |   | 1   |
| 700 199  | USB Stick Flash Drive HV Diagnostics                             |   | 1   |
|          | HVA28TD Shipping Box   |   | 1   |
|          | HVA28TD Laptop bag HV Diagnostics for Test leads/accessories     |   | 1   |
|          | HVA28TD riser for Pelican Case                                   |  | 1   |
|          | HVA28TD Operation Manual   |  | 1   |
|          | HVA28TD PC Software:“HVA Control Center” and “TD Control Center” |  | 1   |

## 4 Design and Construction

### 4.1 Control Elements

HVA28TD control and connection components are located on the front panel.



| Orientation | Description  |
|-------------|--|
| Front Panel | <ul style="list-style-type: none"> <li>• Test controls and emergency shutdown</li> <li>• HV status information</li> <li>• Cable and power source connections</li> <li>• Air vent</li> <li>• USB</li> </ul> |

### Switches and Controls



| Pos. | Name               | Description   |
|------|--------------------|---|
| 1    | Emergency OFF      | <p>Activates emergency shutdown.<br/>Operation is only possible when Emergency OFF is deactivated.</p> <ul style="list-style-type: none"> <li>To Activate Emergency Off → Press in</li> <li>To Deactivate Emergency Off → Release latch and rotate</li> </ul> |
| 2    | LED green          | <p>Indicates HV status.</p> <p>★ Green light indicates → High Voltage is OFF</p>  |
| 3    | LED red            | <p>Indicates HV status.</p> <p>★ Red light indicates → High Voltage is ON (possible DANGER)<br/>→ DUT not discharged<br/>(residual voltage &gt;100V)</p>  |
| 4    | Display screen     | Displays menu, options and status information.  |
| 5    | Navigation knob    | <p>Enables user to select options and functions shown on display.<br/>See 4.2 User Interface</p> <ul style="list-style-type: none"> <li>To scroll selection up or down → Rotate</li> <li>To enter selection → Click (push in)</li> </ul>                      |
| 6    | HV switch [on/off] | <p>Activates high voltage.</p> <ul style="list-style-type: none"> <li>To activate HV output → Press within 10 seconds after START<br/>See 5.2 Manual Test Procedure<br/>See 5.3 Automatic Test Procedure</li> </ul>   |











| Pos. | Name                | Description  |
|------|---------------------|--|
| 7    | Key switch [on/off] | <p>Locks the unit to prevent against unauthorized use.</p> <ul style="list-style-type: none"> <li>To disable unit → Remove key from the OFF Position</li> <li>To reactivate unit → Replace key and turn to ON Position.</li> </ul> |
| 8    | Grounding connector | Serves as connection point from HVA to ground.   |
| 9    | Power supply plug   | Serves as connection point from the HVA to the 100V – 240V, 50/60 Hz powers source.  |
| 10   | HV output connector | <p>Serves as connection point from the HVA to the HV test lead.</p> <p>To connect → Screw the HV test lead into the HV output connector (as long as a click can be heard) and tighten</p>  |
| 11   | Air Vent            | Air inlet with filter, for cooling of electronic elements.   |
| 12   | Air Vent            | Air outlet, for cooling of electronic elements.  |
| 13   | Communication port  | <p>Serves as connection point from the HVA to a USB device.</p>    |

## 4.2 User Interface

### Main Screen



|                      | Element   | Description  |
|----------------------|---|--|
| Title                |    | After activating the unit, display shows "Main Menu"               |
| Unit                 |    | Indicates type of unit operated                                    |
| Date and Time        |    | Indicates day, date and time                                       |
| USB                  |  | Indicates if USB is enabled (green) or disabled (red)              |
| Bluetooth            |  | Indicates if Bluetooth is enabled (green) or disabled (red)        |
| Scroll Button        |  | If active, scroll up or down the screen                            |
| Up and Down Arrow    |  | Navigate with these arrows up and down if a Control Box is active. |
| Control Box Active   |  | Box is active, chose given selections                              |
| Control Box Inactive |  | Box inactive, no selections to be chosen                           |

## Display Navigation

The navigation “knob (5) enables the user to select or change options shown on the HVA display screen (4).

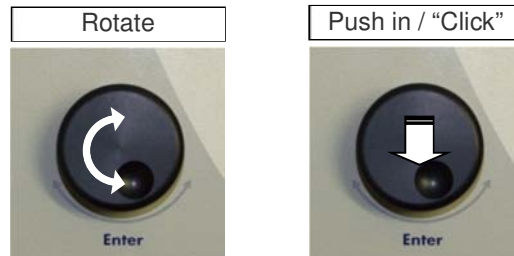

- To move to another item in a menu list or to any other field possible on the actual displayed screen→ Rotate the knob.
- To scroll through options or to change value displayed of an active field→ Rotate the knob.
- To select marked option or to accept set value accept→ Push in / “click”



### 4.3 Instrument Set-up





The HVA28TD instrument settings should be established prior to first utilization and can be modified at any time thereafter. “Instrument Settings” is found in the main menu.



#### Instrument Setup

Steps IS1- IS7 describe how to **do the Instrument Setup**.

| Step  | Procedure (Instrument Setup)     |
|---|----------------------------------|
| <p><b>IS1: Settings</b></p>          | <p>Select “Settings”</p>         |
| <p><b>IS2: Instrument Setup</b></p>  | <p>Select “Instrument Setup”</p> |

| Step   | Procedure (Instrument Setup)   |
|--|--|
| <p><b>IS3: Set Date and Time</b></p>  | <p>Select "Set Date and Time" from "Instrument Settings" menu to arrive at appropriate screen.</p>                                 |
| <p><b>IS4: Set Date and Time</b></p>  | <p>Set Date and Time.</p>  |
| <p><b>IS5: Units</b></p>            | <p>Choose between Metric and Feet.</p>   |
| <p><b>IS6: Reporting</b></p>        | <p>Choose one of the reporting types:</p> <ul style="list-style-type: none"> <li>• Basic (only Report Title is entered)</li> </ul> |

**Step**

**Procedure** (Instrument Setup)

**IS7: Bluetooth**



Activate or deactivate Bluetooth



**IS8: Update from USB**



Put the USB flash drive into the Communication Port (13) and the take updates from the USB stick.





## System Information

Steps **SI1- SI3** describe how to do find the **System Information**.

| Step  | Procedure (System Information)  |
|---|---|
| <p><b>SI1: Settings</b></p>                  | <p>Select "Settings"</p>  |
| <p><b>SI2: System Information</b></p>       | <p>Select "System Info"</p>   |
| <p><b>SI3: See System Information</b></p>  | <p>"System Information" displays HVA characteristics. This information cannot be modified by the operator:</p> <ul style="list-style-type: none"> <li>• Version HMI</li> <li>• Version CTRL</li> <li>• Serial number: HVA unit serial number</li> </ul> |

## Language and Region

Steps L1 – L4 describe how to do set **Language and Region**.

| Step  | Procedure (System Information)  |
|---|---|
| <p><b>L1: Settings</b></p>             | <p>Select "Settings"</p>  |
| <p><b>L2: System Information</b></p>  | <p>Select "Language and Region"</p>   |
| <p><b>L3: Language</b></p>           | <p>Choose Language:</p> <ul style="list-style-type: none"> <li>• English</li> <li>• German</li> <li>• Dutch</li> <li>• French</li> </ul>  |
| <p><b>L4: Region</b></p>             | <p>Choose Region:</p> <ul style="list-style-type: none"> <li>• Europe</li> <li>• UK</li> <li>• USA</li> <li>• Russia</li> <li>• China</li> <li>• South Africa</li> <li>• Asia</li> <li>• International</li> </ul> |



## 4.4 Operation Modes

The following describes the scope of each HVA28TD operation modes: **Test Modes**, **Output Modes** (Waveform), **Arc Management Modes**, and **Data Transfer Modes**.

### Test Modes

The HVA28TD can be operated in “Manual” or “Automatic” mode. For detailed procedure, see 5.2 - Manual Test Mode, and 5.3 - Automatic Test Mode.

| Test Mode | Characteristics  |
|-----------|--|
| Manual    | Designed to facilitate rapid testing. Test Parameters of the last manual test appear as the default setting. <ul style="list-style-type: none"> <li>• Test parameters can be changed immediately before activating a test.</li> <li>• Basic reporting most appropriate setting. (Extended reporting will generate a report with most fields left blank)</li> </ul> |
| Automatic | Designed for testing with predefined configuration in order to satisfy specific requirements (e.g. IEEE, IEC standards). <ul style="list-style-type: none"> <li>• Test sequence must be configured and saved at any time before testing.</li> <li>• Extended reporting most appropriate setting.</li> </ul>  |

### Output Modes

The HVA can carry out HV28TD test in the following output modes:

| Output Mode           | Characteristics  |
|-----------------------|--|
| DC [- /+]             | Single polarity output. DUT is polarized (negative / positive) with respect to ground. <ul style="list-style-type: none"> <li>• <b>Not</b> recommended for testing extruded cables (e.g. XLPE cables).</li> <li>• Measured valued: Dielectric loss of the DUT (including leakage current across terminations)</li> <li>• DC - : Most commonly used DC output mode</li> </ul> |
| VLF Sinewave          | Default waveform <ul style="list-style-type: none"> <li>• Suitable for testing extruded cables (e.g. XLPE cables).</li> <li>• Measured valued: RMS</li> </ul>  |
| VLF Squarewave        | <ul style="list-style-type: none"> <li>• Suitable for testing extruded cables (e.g. XLPE cables).</li> <li>• Measured valued: RMS</li> </ul>   |
| Vacuum Bottle Testing | <ul style="list-style-type: none"> <li>• Not suitable for testing with DC above DUT voltage rating (X-ray Hazard)</li> <li>• Possible in Manual and Automatic test modes</li> <li>• Trip current and rise rate are user defined</li> <li>• Measured valued: kV</li> </ul>  |

| Output Mode                | Characteristics   |
|----------------------------|---|
| Sheath Test                | <ul style="list-style-type: none"> <li>Suitable for Sheath Test</li> <li>Duration is user defined</li> <li>Unmax 10 kV</li> </ul>   |
| Sheath Fault Location Mode | <ul style="list-style-type: none"> <li>Suitable for Sheath Fault Location</li> <li>Duration is user defined</li> <li>Pulse user defined<br/>(1:3/4 s, 1:5/4 s, 1:5/6 s, 1:9/6 s)</li> </ul> |

### Arc Management Modes

If a fault is detected during a HV test, the arc management mode determines how the failure is managed. The “Burn on Arc” mode will condition the fault whereas the “Trip out on Arc” mode will immediately switch HV off.

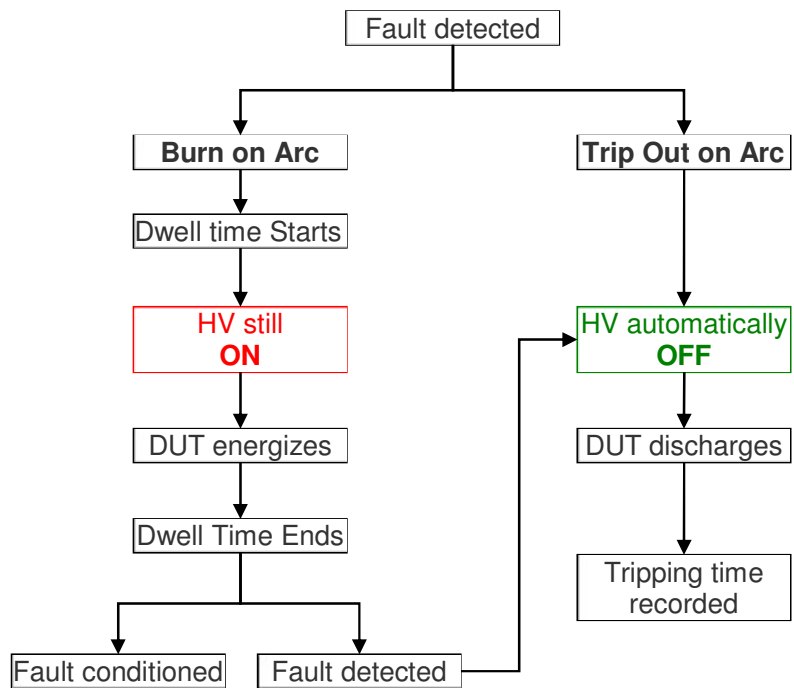

## Data Transfer Modes

The HVA28TD built in memory can save up to 50 reports and 40 test sequences. Data storage location and transfer capability depends on the configuration of the communication port (13).

| Configuration | Characteristics  |
|---------------|--|
| USB           | <ul style="list-style-type: none"><li>• The USB Flash Drive goes into the communication port (13)</li><li>• When connected, left hand corner of main menu displays “USB” enabled (green).</li><li>• Test sequences are directly saved to HVA28TD memory</li><li>• All reports saved in HVA28TD memory can be transferred to the linked USB stick.</li><li>• Reports saved on the USB stick can be viewed on the HVA28TD display.</li></ul> |

## 5 Test Procedure



### DANGER

#### Electric Shock Hazard!

**All procedures must comply with local safety regulations.**

- Before operating the HVA28TD, equipment set-up procedure must be completed!
- Cables must be connected in the proper sequence!
- Before, turning on the power supply and before activating the HVA28TD, verify that all system elements are properly grounded!  
See 5.1 Equipment Set-up: Steps S1 –S7

### 5.1 Equipment Set-up

Steps **S1-S7** describe the **Equipment Set-up** procedure. When carrying out multiple tests, the ground and power supply connections must always remain intact. The HV test lead must be reconnected before each subsequent test (i.e. repeat procedure as of step S3).

Connection Diagram: Cable Testing

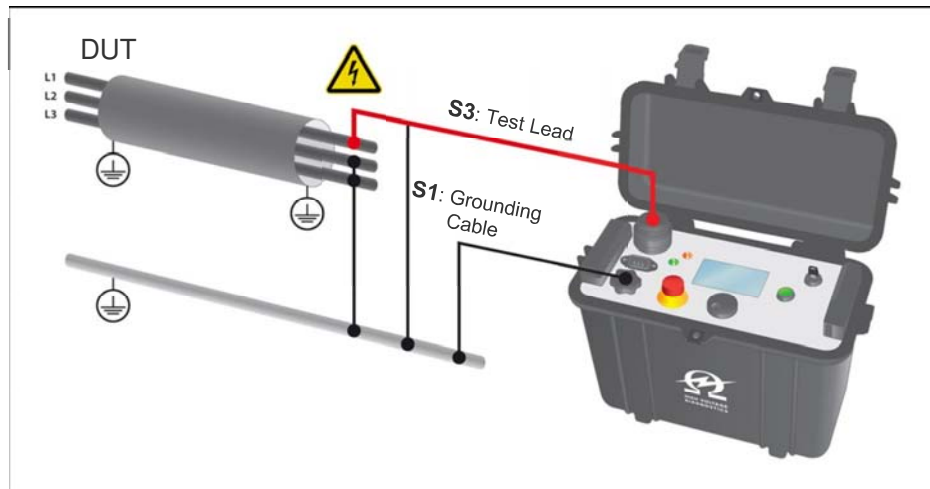

| Step | Procedure  |
|------|--|
| S1   | Connect Grounding Cable <ul style="list-style-type: none"> <li>• Connect grounding cable to the HVA grounding connector (10)</li> <li>• Connect grounding cable to the DUT ground</li> </ul> |
| S2   | Connect Power Supply Cable <ul style="list-style-type: none"> <li>• Connect the power supply cable to the HVA power supply plug (9)</li> </ul>   |



| Step | Procedure  |
|------|--|
| S3   | Connect HV Test Lead <ul style="list-style-type: none"><li>• Screw the HV test lead into the HVA HV output connector (11)</li><li>• Connect the HV cable shield to ground.</li><li>• Connect other end of HV test lead (clamp including screen protector) to the DUT.</li></ul>  |
| S4   | Verify Connections <ul style="list-style-type: none"><li>• Check that all cables are attached securely.</li></ul>  |
| S5   | Configure communication port (13)<br>For USB Data Transfer Mode: <ul style="list-style-type: none"><li>• Connect the USB Flash adapter</li><li>• Insert USB stick</li></ul>  |
| S6   | Turn key switch (7) to the “ON” position   |
| S7   | The HVA system automatically boots. <ul style="list-style-type: none"><li>• Start-up default screen appears<br/>“Start Test” screen</li></ul> Select appropriate option from default screen and proceed to appropriate section for further instructions: <ul style="list-style-type: none"><li>• See 5.2 Manual Test Mode or<br/>See 5.3 Automatic Test Mode</li></ul> |

## 5.2 Manual Test Mode

This HVA28TD test mode facilitates rapid testing. If the default is the “Manual Mode Screen”, a test with the same settings as the previous test can be started directly after activating the system.

### Setting Manual Test Parameters

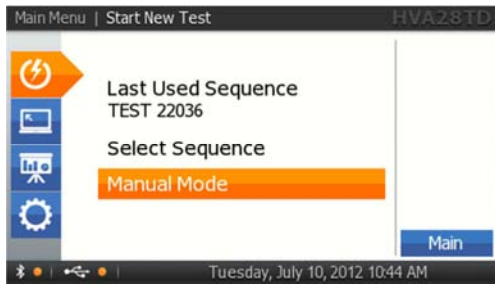
Steps **MS1-MS11** describe how to **set manual mode test parameters**.

| Step   | Procedure (Set Manual Test Parameters)  |
|--|---|
| <p><b>MS1: Start new Test</b></p>       | <p>Select “Start Test”</p>  |
| <p><b>MS2: Start Manual Mode</b></p>  | <p>Select “Manual Mode”</p>   |
| <p><b>MS3: SETUP</b></p>              | <p>To set the waveform, frequency, or test duration, select “SETUP” on bottom of “Manual Test” screen</p> |

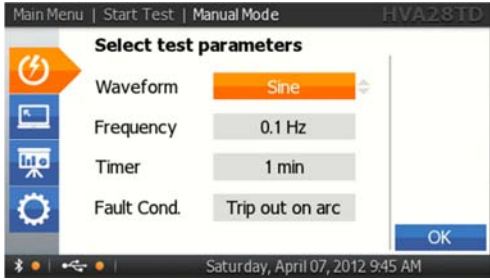
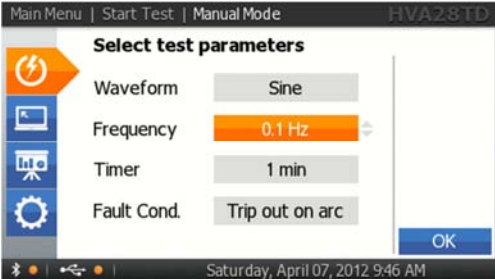
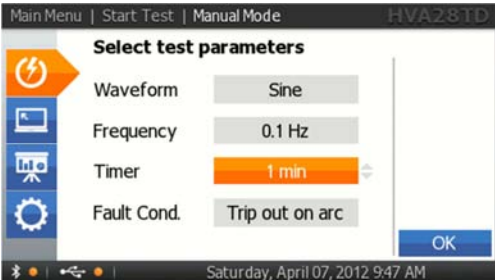
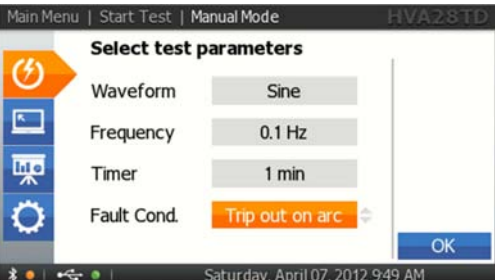
| Step   | Procedure (Set Manual Test Parameters)   |
|--|--|
| <p><b>MS4: SETUP: Waveform</b></p>    | <p>Select one of the following output modes:</p> <ul style="list-style-type: none"> <li>• Sine wave</li> <li>• Square wave</li> <li>• DC+</li> <li>• DC-</li> <li>• Vacuum Bottle Test</li> <li>• Sheath Test</li> <li>• Sheath Fault Location</li> </ul>                              |
| <p><b>MS5: SETUP: Frequency</b><br/>Sinewave, Squarewave</p>                 | <p>Set the frequency to as close to 0.1Hz as possible.</p> <ul style="list-style-type: none"> <li>• 0.1 Hz/Auto: Recommended setting that automatically maintains the frequency as close to 0.1Hz as possible</li> </ul> <p>To correct entry select “CANCEL” at bottom of display.</p> |
| <p><b>MS6: SETUP: Duration</b><br/>(Not applicable Vacuum Bottle Test)</p>  | <p>To modify the duration, rotate navigation knob (5).</p> <p>To accept value, push in knob.</p> <ul style="list-style-type: none"> <li>• Min. test duration = 1 minute</li> <li>• Max. test duration = 24 hours</li> </ul> <p>To return to “Manual Mode” screen, select “OK”</p>      |
| <p><b>MS7: Arc Management Mode</b></p>                                      | <p>Rotate navigation knob (5) until the field on bottom of the screen is highlighted.</p> <p>To change the mode, push in the knob. One of the following modes will be displayed:</p> <ul style="list-style-type: none"> <li>• Trip out on Arc</li> <li>• Burn on Arc</li> </ul>        |

**Step**

**MS8: Preset Test Voltage:**

(optional-voltage can be set once test has been initiated!)



**Procedure** (Set Manual Test Parameters)

Entering the test voltage before activating the manual mode test “START” is **optional**.

In manual mode, voltage can be set once test has been initiated!

To set the test voltage before activating the manual mode test “START”:

Rotate navigation knob (5) until voltage field is framed. The dot in upper right hand corner indicates that the test voltage is in preset mode. To modify the value, rotate navigation knob (5).



- Min. test voltage = 0.0kV
- Max. voltage = 20.0kVrms (VLF),  
±28.0kV DC, 28.0kV Squarewave

To accept the value, push in knob (5).The dot in upper right hand disappears indicating that the test voltage is set.

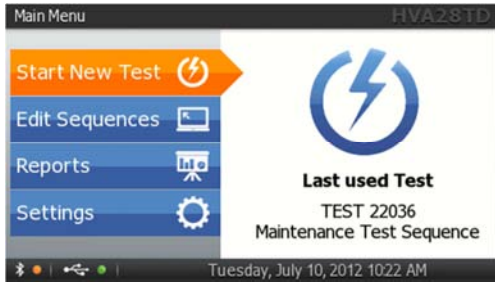
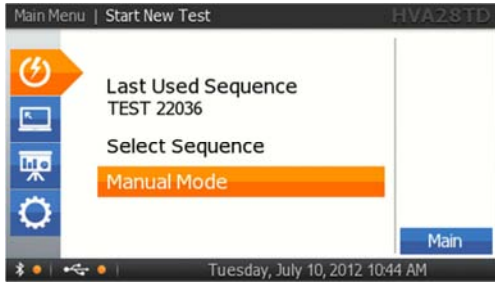

## Running a Manual Test

Steps **MR1-MR9** describe how to **run a test in the manual mode.**

| Step  | Procedure (Run Manual Test)  |
|---|--|
| <p><b>MR1: Start new Test</b></p>      | <p>Select "Start Test"</p>   |
| <p><b>MR2: Start Manual Mode</b></p>  | <p>Select "Manual Mode"</p>  |
| <p><b>MR3: START Test</b></p>        | <p>Start the test when test parameters displayed on the "Manual Test" screen are correct. Rotate navigation knob (5) until the "START" field is highlighted. To run the test, push in knob (5)</p> |
| <p><b>MR4: Report Title</b></p>      | <p>For naming "Report Title", see 7 Reporting Procedure – Report Naming Instructions.</p>  |

**Step**

**Procedure** (Run Manual Test)

**MR5: HV Activation**



Once the activation screen appears,

- Press the HV switch (6) within 10 seconds.

If the HV switch is not activated within the 10 second window, the “Manual Mode” screen will reappear.

**MR6: Test Start up**



“Startup” appears on the screen to indicate that the HVA is initializing the test

**MR7: Set Test Voltage**

(if not preset in step MS 8)

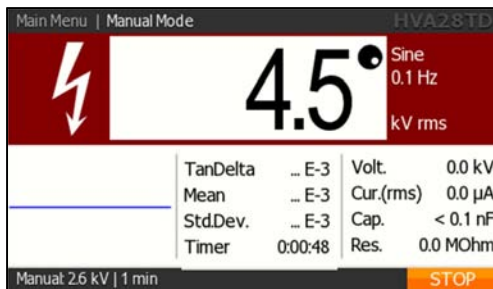

Rotate navigation knob (5) to modify the voltage value.

- Min. test voltage = 0.0kV
- Max. voltage = 20.0kV rms (VLF), ±28.0kV DC, 28.0kV Squarewave

**MR8: Test**

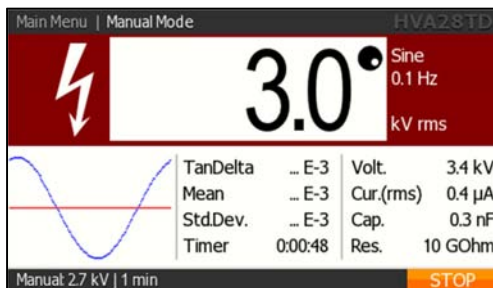

Test begins automatically  
The bottom of the screen indicates the lapsed time

T: lapsed time / total test duration

| Step  | Procedure (Run Manual Test)  |
|---|--|
| <p data-bbox="313 296 508 327"><b>MR9: Test End</b></p>  | <p data-bbox="898 338 1320 369">Display indicates end of Manual Test</p> |

### 5.3 Automatic Test Mode

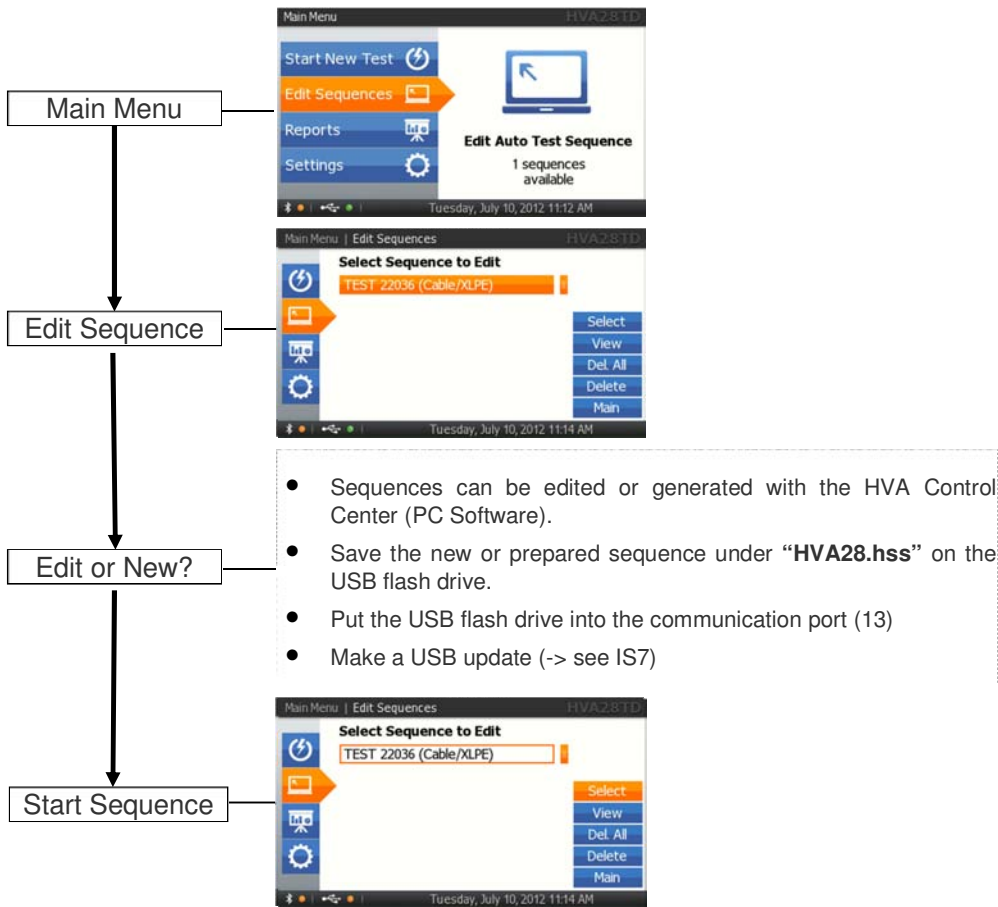

This HVA28TD test mode facilitates testing in order to satisfy specific requirements (e.g. IEEE, IEC standards). The test sequence can be configured, modified and saved at any time before testing.

#### Configuring Auto Test. Sequence- Overview

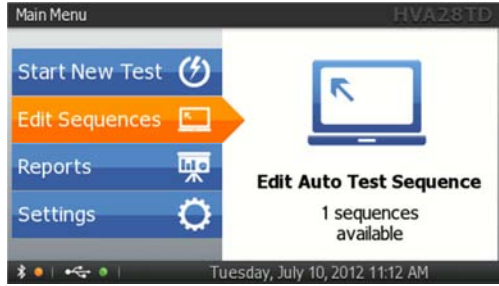
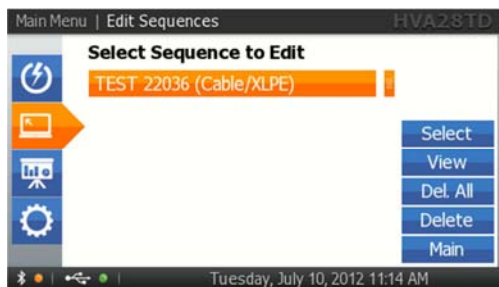

## Configuring Auto Test. Sequence on the HVA Unit

Steps AS1-AS3 describe how to **configure a test sequence**.

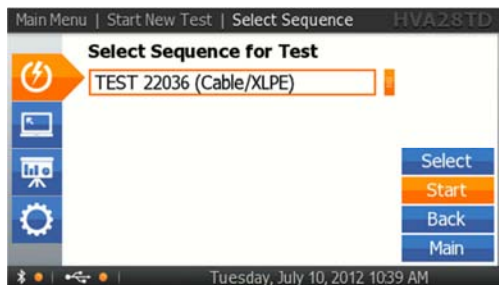
| Step  | Procedure (Configure Automatic Sequence)  |
|---|---|
| <p><b>AS1: Edit Sequences</b></p>  | <p>Select "Edit Sequences"</p>  |
| <p><b>AS2: EDIT or NEW?</b></p>   | <p>To edit or generate new test sequences change to the HVA28 Control Center (PC Software) -&gt; see Page 35 PC1-PC3.</p> <ul style="list-style-type: none"> <li>• Edit or make a new test sequence on the HVA28 Control Center</li> <li>• Save the sequence on the USB flash drive</li> </ul> <div data-bbox="1055 976 1461 1018" style="background-color: #0070C0; color: white; padding: 5px; text-align: center;"><b>NOTICE</b></div> <div data-bbox="917 997 1031 1102" style="float: left; margin-right: 10px;">  </div> <p>The file must be saved under <b>"HVA28.hss"</b> on the USB flash drive.</p> <ul style="list-style-type: none"> <li>• Put the USB flash drive into the communication port (13)</li> <li>• Make a USB update (Settings -&gt; see IS7)</li> </ul> <p>The sequence is found in the "Edit Sequences" Menu display</p> |
| <p><b>AS3: DUT</b></p>           | <p>Select one of the Sequences which are already stored in memory.</p>  |

## Configuring Auto Test. Sequence- Detailed Steps

Steps **AS1-AS3** describe how to **configure a test sequence** with the HVA Control Center.

### Step

### Procedure (Configure Automatic Sequence)

#### PC1: Edit Sequences



Start HVA Control Center on the computer and press button “Manage Test Sequences”

#### PC2: Save Sequence



Adjust your specifications and press “Update Changes”

Afterwards press button “Save Sequences”

#### PC3: Save on USB Flash Drive

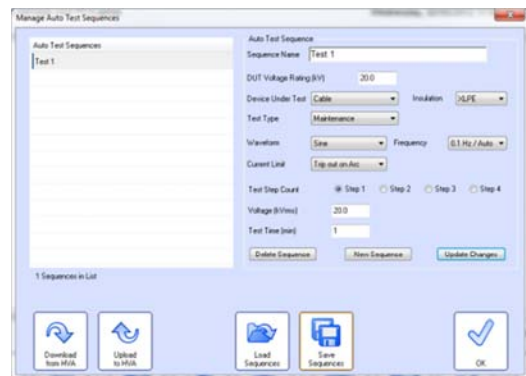

Save Sequences as ‘HVA28.hss’ file!



### NOTICE

The file must be saved under “HVA28.hss” on the USB flash drive. Otherwise it won't work!

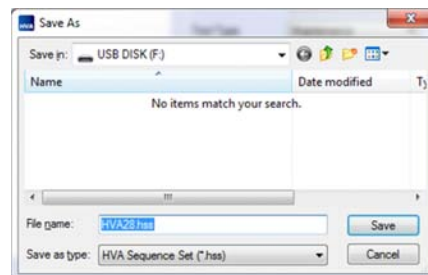

## Running an Automatic Test - Overview

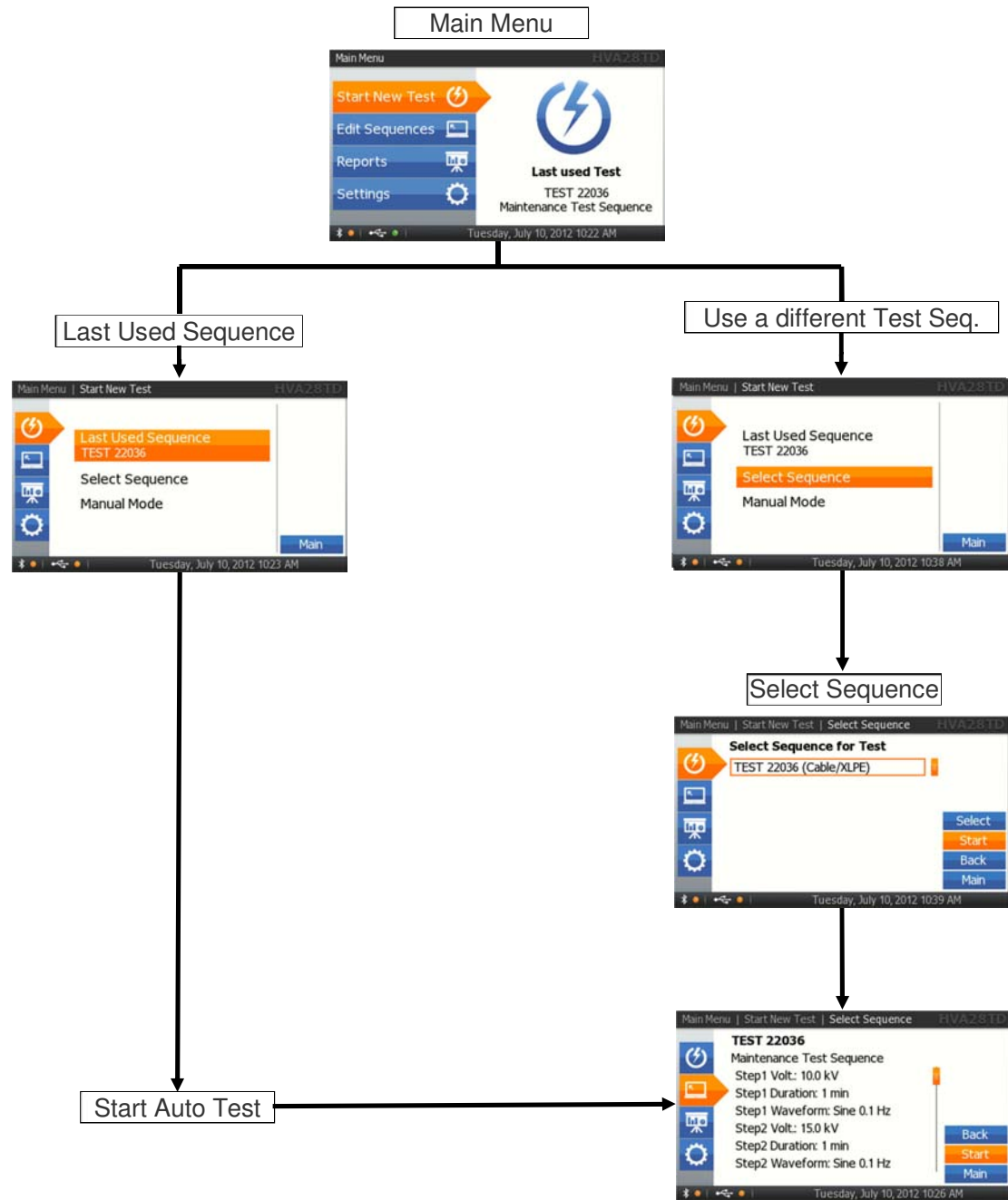



## Running an Automatic Test - Detailed Steps

Steps **AR1 – AR9** describe how to **run a test in the Automatic Mode**.

| Step   | Procedure (Run Automatic Test )   |
|--|---|
| <p><b>AR1: Use Last Seq. or Start New Test</b></p>  | <p>Select "Start Test"</p>  |
| <p><b>AR2: Chose Test</b></p>                      | <p>To repeat the previous test sequence:</p> <ul style="list-style-type: none"> <li>• Select "Last Used Sequence" from "Main Menu"</li> <li>• Proceed to Step AR4</li> </ul> <p>Otherwise, select:</p> <ul style="list-style-type: none"> <li>• "Start Sequence"</li> </ul> |
| <p><b>AR3: Sequence</b></p>                       | <p>Select one of the Sequences</p>  |
| <p><b>AR4: Sequence</b></p>                       | <p>All information about the chosen sequence is displayed.</p>  |

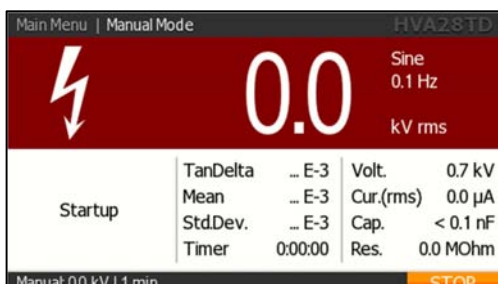
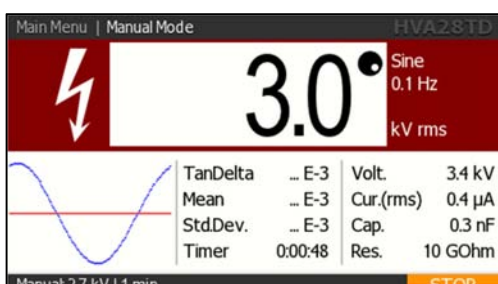

| Step   | Procedure (Run Automatic Test)   |
|--|--|
| <p><b>AR5: Report Title</b></p>     | <p>For naming “Report Title”, see 7 Reporting Procedure – Report Naming Instructions.</p>  |
| <p><b>AR6: HV Activation</b></p>    | <p>Once the activation screen appears,</p> <ul style="list-style-type: none"> <li>Press the HV switch (6) within 10 seconds.</li> </ul> <p>If the HV switch is not activated within the 10 second window, the “Start Auto Test Seq.” screen will reappear.</p> |
| <p><b>AR7: Test Start up</b></p>  | <p>“Startup” appears on the screen to indicate that the HVA is initializing test</p>   |
| <p><b>AR8: Test</b></p>           | <p>Test begins automatically</p> <p>The bottom of the screen indicates the lapsed time<br/>T: lapsed time / total test duration</p>  |

**Step**

**AR9: Test End**







**Procedure (Run Automatic Test )**

Display indicates end of Auto Test

If reporting is active, the user can immediately view the report.

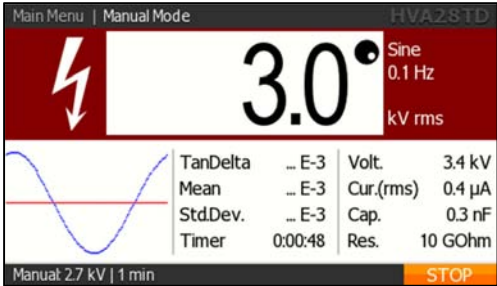
## 5.4 Interrupting a Test

Once a test has started, it can be interrupted at any time. It is recommended to select the appropriate method corresponding to the situation

| Situation  | Procedure   |
|--|---|
| <p>Routine STOP<br/>(No emergency)</p>  | <p>When a test is in progress, “STOP” on the display screen is highlighted.<br/>To interrupt the test, push in / click the navigation knob (5)</p> <ul style="list-style-type: none"> <li>• HVA28TD <b>software</b> deactivates HV</li> <li>• Test stops</li> </ul> |
| <p>Alternative</p>                     | <p>When a test is in progress, press the HV switch (6) to deactivate high voltage.</p> <ul style="list-style-type: none"> <li>• HVA28TD <b>hardware</b> deactivates HV</li> <li>• Test stops</li> </ul>   |
| <p>Emergency Stop</p>                 | <p>In an emergency situation, press the Emergency Off (1) to shutdown the system.</p> <ul style="list-style-type: none"> <li>• HVA28TD <b>hardware</b> deactivates HV</li> <li>• Test stops</li> </ul>  |
|                                       | <p>After test interruption, a message is displayed indicating that the test has been terminated by the user.</p>  |

## 6 Tangent Delta

### 6.1 Application

The HVA28TD provides the testing and commissioning engineer/technician with a versatile high voltage tan delta measuring system suitable for testing medium voltage electrical insulation systems such as cables (including: XLPE, PE, EPR, PILC, etc.), capacitors, switchgear, transformers, rotating machines, insulators and bushings.

Tan Delta testing enables the cable test engineer to detect insulation defects before the cable fails in service. The HVA28TD is a HVA test unit with an integrated tangent delta measuring system. The tan delta test results of the test object can now be easily measured, recorded and screen on the display. The results can be stored easily via USB flash drive.

Additional HVA28TD PC Software is included in the scope of delivery. With this PC Software the test results can be easily stored on a standard PC or Laptop for analysis, trending or quality control. This enables the cable engineer to now make tangent delta testing a routine maintenance test.

### 6.2 Equipment Set-up

Connection Diagram: Cable Testing

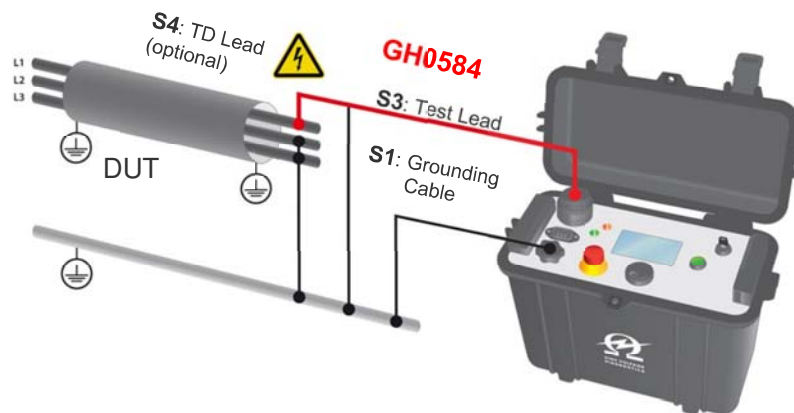

| Step | Procedure  |
|------|--|
| S1   | Connect Grounding Cable <ul style="list-style-type: none"> <li>Connect grounding cable to the HVA grounding connector (10)</li> <li>Connect grounding cable to the DUT ground</li> </ul> |
| S2   | Connect Power Supply Cable <ul style="list-style-type: none"> <li>Connect the power supply cable to the HVA power supply plug (9)</li> </ul>   |



| Step | Procedure   |
|------|---|
| S3   | <p>Connect HV Test Lead</p> <ul style="list-style-type: none"> <li>• Screw the HV test lead into the HVA HV output connector (11)</li> <li>• Connect the HV cable shield to ground.</li> <li>• Connect other end of HV test lead (clamp including screen protector) to the DUT.</li> </ul>  |
| S4   | <p>Clean the terminations prior to testing. If possible, connect the external guard like it's shown in the pictures below (702 509).</p>  |
| S5   | <p>Verify Connections</p> <ul style="list-style-type: none"> <li>• Check that all cables are attached securely.</li> </ul>  |
| S6   | <p>Configure communication port (13)</p>  |
| S7   | <p>Turn key switch (7) to the "ON" position</p>   |
| S8   | <p>The HVA system automatically boots.</p> <ul style="list-style-type: none"> <li>• Start-up default screen appears "Start Test" screen</li> </ul> <p>Select appropriate option from default screen and proceed to appropriate section for further instructions:</p> <ul style="list-style-type: none"> <li>• See 5.2 Manual Test Mode or</li> <li>• See 5.3 Automatic Test Mode</li> </ul> |



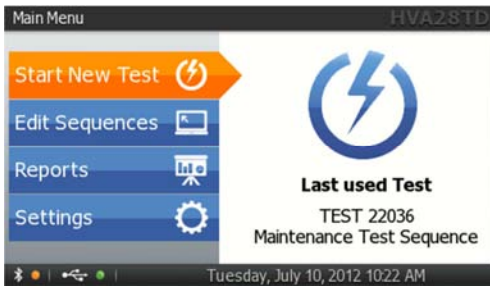
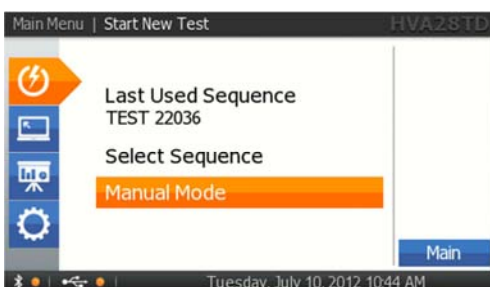

## 6.3 Tangent Delta Test

### Running a Manual Test with Tangent Delta

Steps TD1 – TD9 describe how to run a test in the manual mode with Tangent Delta.

| Step  | Procedure (Run Manual Test)  |
|---|--|
| <p><b>TD1: Start new Test</b></p>      | <p>Select "Start Test"</p>   |
| <p><b>TD2: Start Manual Mode</b></p>  | <p>Select "Manual Mode"</p>  |
| <p><b>TD3: START Test</b></p>        | <p>Start the test when test parameters displayed on the "Manual Test" screen are correct. Rotate navigation knob (5) until the "START" field is highlighted. To run the test, push in knob (5)</p> |

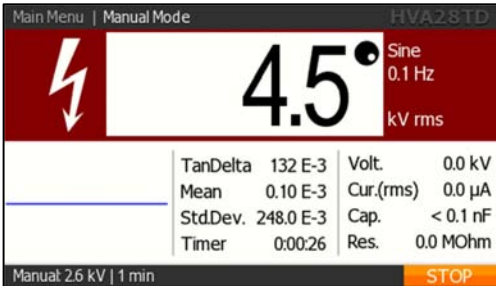
| Step  | Procedure (Run Manual Test)   |           |           |           |          |      |         |           |           |          |         |          |           |       |          |      |          |  |      |          |  |
|---|---|-----------|-----------|-----------|----------|------|---------|-----------|-----------|----------|---------|----------|-----------|-------|----------|------|----------|--|------|----------|--|
| <p><b>TD4: HV Activation</b></p>   | <p>For naming “Report Title”, see 6 Reporting Procedure – Report Naming Instructions.</p>   |           |           |           |          |      |         |           |           |          |         |          |           |       |          |      |          |  |      |          |  |
| <p><b>TD5: HV Activation</b></p>    | <p>Once the activation screen appears,</p> <ul style="list-style-type: none"> <li>• Press the HV switch (6) within 10 seconds.</li> </ul> <p>If the HV switch is not activated within the 10 second window, the “Manual Mode” screen will reappear.</p> |           |           |           |          |      |         |           |           |          |         |          |           |       |          |      |          |  |      |          |  |
| <p><b>TD6: Test Start up</b></p>  <table border="1" data-bbox="391 1234 878 1360"> <tr> <td rowspan="4">Startup</td> <td>TanDelta</td> <td>... E-3</td> <td>Volt.</td> <td>0.7 kV</td> </tr> <tr> <td>Mean</td> <td>... E-3</td> <td>Cur.(rms)</td> <td>0.0 µA</td> </tr> <tr> <td>Std.Dev.</td> <td>... E-3</td> <td>Cap.</td> <td>&lt; 0.1 nF</td> </tr> <tr> <td>Timer</td> <td>0:00:00</td> <td>Res.</td> <td>0.0 MOhm</td> </tr> </table>   | Startup   | TanDelta  | ... E-3   | Volt.     | 0.7 kV   | Mean | ... E-3 | Cur.(rms) | 0.0 µA    | Std.Dev. | ... E-3 | Cap.     | < 0.1 nF  | Timer | 0:00:00  | Res. | 0.0 MOhm | <p>“Startup” appears on the screen to indicate that the HVA is initializing the test</p> |      |          |  |
| Startup   |   | TanDelta  | ... E-3   | Volt.     | 0.7 kV   |      |         |           |           |          |         |          |           |       |          |      |          |  |      |          |  |
|   |   | Mean      | ... E-3   | Cur.(rms) | 0.0 µA   |      |         |           |           |          |         |          |           |       |          |      |          |  |      |          |  |
|   |   | Std.Dev.  | ... E-3   | Cap.      | < 0.1 nF |      |         |           |           |          |         |          |           |       |          |      |          |  |      |          |  |
|   | Timer   | 0:00:00   | Res.      | 0.0 MOhm  |          |      |         |           |           |          |         |          |           |       |          |      |          |  |      |          |  |
| <p><b>TD7: Set Test Voltage</b><br/>(if not preset in step MS 8)</p>  <table border="1" data-bbox="391 1640 878 1766"> <tr> <td></td> <td>TanDelta</td> <td>132 E-3</td> <td>Volt.</td> <td>0.0 kV</td> </tr> <tr> <td></td> <td>Mean</td> <td>0.10 E-3</td> <td>Cur.(rms)</td> <td>0.0 µA</td> </tr> <tr> <td></td> <td>Std.Dev.</td> <td>248.0 E-3</td> <td>Cap.</td> <td>&lt; 0.1 nF</td> </tr> <tr> <td></td> <td>Timer</td> <td>0:00:26</td> <td>Res.</td> <td>0.0 MOhm</td> </tr> </table> |   | TanDelta  | 132 E-3   | Volt.     | 0.0 kV   |      | Mean    | 0.10 E-3  | Cur.(rms) | 0.0 µA   |         | Std.Dev. | 248.0 E-3 | Cap.  | < 0.1 nF |      | Timer    | 0:00:26  | Res. | 0.0 MOhm | <p>Rotate navigation knob (5) to modify the voltage value.</p> <ul style="list-style-type: none"> <li>• Min. test voltage = 0.0kV</li> <li>• Max. voltage = 20.0kV rms (VLF), ±28.0kV DC, 28.0kV Squarewave</li> </ul> |
|   | TanDelta  | 132 E-3   | Volt.     | 0.0 kV    |          |      |         |           |           |          |         |          |           |       |          |      |          |  |      |          |  |
|   | Mean  | 0.10 E-3  | Cur.(rms) | 0.0 µA    |          |      |         |           |           |          |         |          |           |       |          |      |          |  |      |          |  |
|   | Std.Dev.  | 248.0 E-3 | Cap.      | < 0.1 nF  |          |      |         |           |           |          |         |          |           |       |          |      |          |  |      |          |  |
|   | Timer   | 0:00:26   | Res.      | 0.0 MOhm  |          |      |         |           |           |          |         |          |           |       |          |      |          |  |      |          |  |

**TD8: Test**

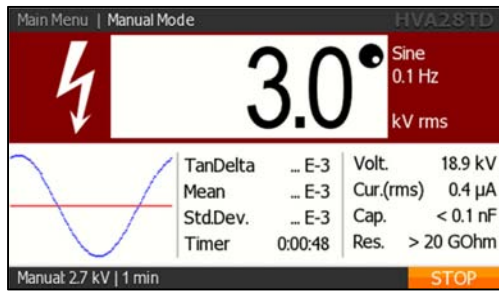

Test begins automatically  
 The bottom of the screen indicates the lapsed time

T: lapsed time / total test duration

**TD9: Test End**



Display indicates end of Manual Test



## 6.4 PC Software HVA28TD

The HVA28TD system is delivered with a set of Windows based software tools that are packaged into a software package. This software connects, records, analyses and reports the test results from the HVA28TD test instrument.

### Description of Elements of the Main Screen:

#### System Information, Title Bar

The Title Bar shows connection status information like the serial of the HVA28TD system that is paired to the current PC.

#### Information Selection Tabs

Use these Tabs to switch between the various information you want to view.

**Phase A-C:** Show detailed TD measurement information of Phase A or B or C. If the corresponding Phase under “Currently Measured” is selected, all new measurements will automatically be inserted under the selected tab.

**Wave View:** If a measurement is in progress, this tab shows a slightly delayed real-time display of the data acquired by the TD measurement system. Voltage and Current are shown. These values are not to scale. The graph is updated after each finished waveform period.

#### Graph TD vs. Voltage:

Graphical display of the TD test results as a function of applied voltage. The values of all three phases can be viewed and compared. The diagram is completely auto-scaling and extracts the mean TD value from the most recent voltage block for a particular phase.

#### Current HVA28TD Value

This field shows the currently measured TD value or the last value if measurement has stopped. Helpful if not in Phase-View, so the current TD value can always be observed.

#### Report Phase Detail

Each Phase Measurement Report consists of header which includes the HVA28TD serial number it was acquired from, and the filename that it was stored under.

### **Report Block Header**

For every detected voltage change during measurement the system automatically creates a new block in the corresponding Phase Tab. Each Block starts with a header, which gives information like the Start Time of the measurement and the updated mean values of this block.

The “Change Phase” Button enables the user to move a selected block to another Phase or to completely remove it from the Report. This is useful if phase test data was mistakenly recorded under the incorrect phase number. This can happen if the user starts a measurement under one phase but does not change the “Currently Measured Phase Selection”. Then the whole block can be easily moved after the full measurement block has been completed.

### **Report Block Measurements**

This grid shows the detailed individual test measurements for each distinct voltage. Each column is described with units in the grid header row.

### **Test Report File Functions – Load, Save, Print ...**

Use these buttons to Load, Save and Print a test report.

The Print function can also be used to create PDF document reports if a PDF Writer or a similar PDF Printer Driver is installed.

## Report Specific Functions

### Clear Report

Clear the current active report test data. Be sure to save your test data before you clear a test report. This function is useful if you want to start a new test and want to “clean” test sheet.

### Edit Report Information

This Form enables the user to save detailed information with the report data.

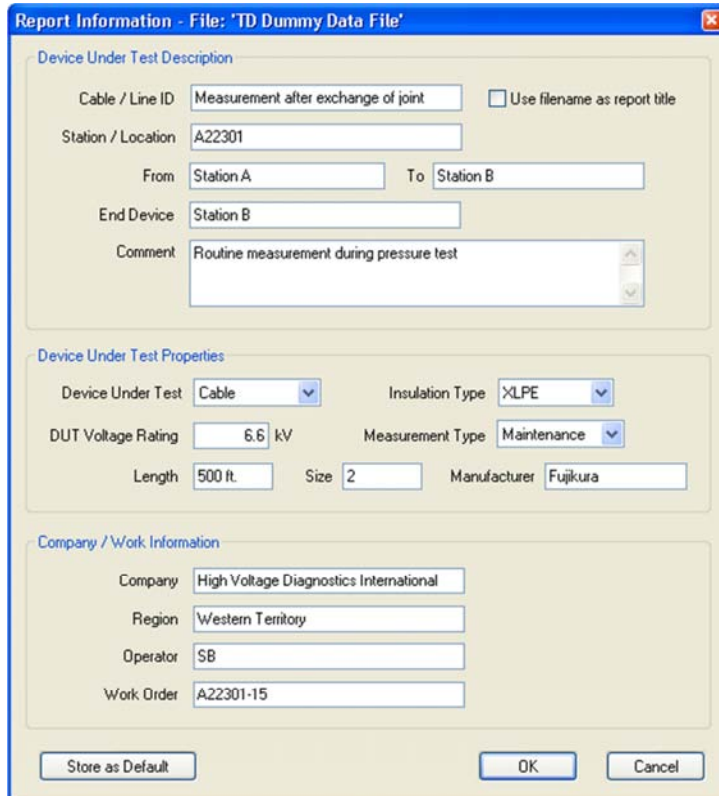

### Cable/Line ID (if cable as DUT is selected)

The user can enter a unique identifier for the Device Under Test (DUT). This Text will also be used (by default) as the title for this Report on the Summary and Printout.

### Store As Default

The user can store certain fields that are not likely to change from one test to another as default start-up fields. These fields are then easily and automatically inserted into any new test reports.  
Fields stored: Station, Company, Region and Operator

### Use filename as report title

If this box is checked, the report filename will be used as the report title instead of the Cable/Line ID field.

### Currently Measuring..... Phase Selection

The phase that is currently being tested by the HVA28TD needs to be selected.

All new measurement data will be put into the corresponding report phase section (tab).

If the operator changes the phase during an active HVA28TD measurement, the change will only occur when the current HVA28TD voltage block is finished to avoid splitting up of the respective HVA28TD measurement data block. The block “under the wrong” phase tab can then be moved to the correct phase section using the “Change Phase” button in the block header as a later stage.

### Graphical View / Diagram

This screen provides a graphical diagram of the Mean HVA28TD measurement data versus the applied test voltage.

The values of all three phases can be viewed and compared. The graph automatically scales and draws the mean HVA28TD values for each voltage block.

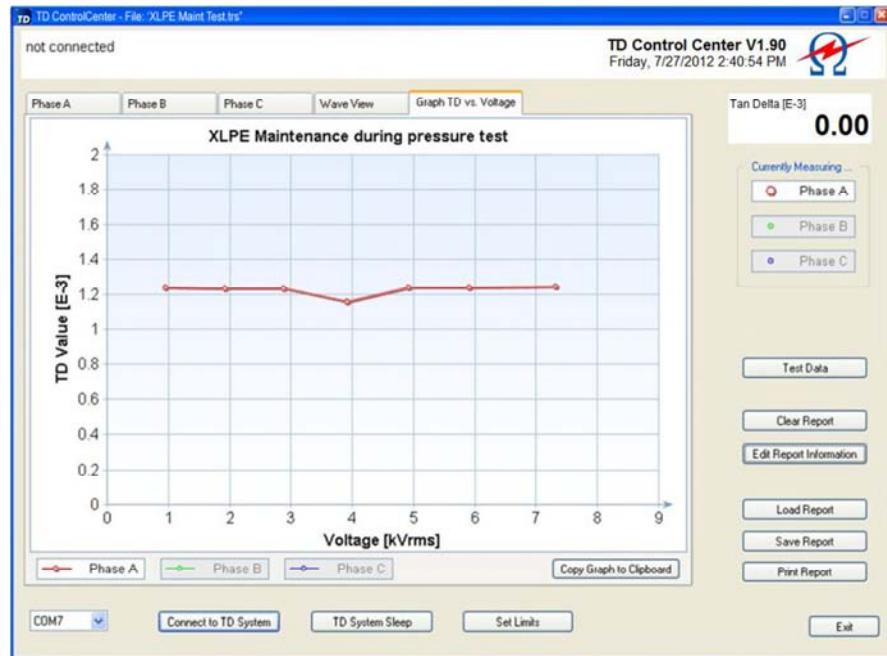

### Phase Selection for Diagram View

Toggle ON/OFF the various phases to display / block out the relevant phase information.

### Copy Graph to Clipboard

Use this function to make a copy the currently shown HVA28TD diagram into the Windows Clipboard. It can then be easily put into many other applications (like Word, Excel) by selecting Paste in the target program.

## 6.5 Bluetooth® Setup and Config Procedure

Since there are various ways to use and configure Bluetooth under Windows operating systems, the following procedures are provided to setup and use Bluetooth wireless HVA28TD measurement system. You will need Administrator Privileges to install the drivers on certain secure networks.

### Communication Parameters for Bluetooth Setup (Advanced Users)

- Bluetooth v1.1 compliant
- Serial Port Profile, only this profile and the corresponding outbound COM port needed
- COM 3 to COM30 are supported with the HVA Control Center
- COM 1 to COM99 are supported with the TD Control Center
- Secure and unsecure communication and pairing supported
- Passkey used is “welcome”, lowercase, (for pairing this is also the PIN-code)

### To install the communication three steps have to be done

- **Step 1:** Installation of Bluetooth driver support on your computer (if not already built-in)
- **Step 2:** Configure Bluetooth support (Initial usage, only has to be done once)
- **Step 3-A/B:** Setting up the HVA28TD Communication Port  
A: With use of External Dongle or B: Windows Supported Hardware  
There are 2 different ways to set up a communication port: one way is directly supported by Windows, and the other way is using the external dongle. See below which procedure is to use with your computer.

### Check Bluetooth Hardware

First check if your computer has a built in Bluetooth communications hardware like most of the newer Notebooks have. Normally they are already configured to use Bluetooth.

In this case, you will not need to use the external USB dongle nor should you install the Bluetooth driver CD supplied.

If you are not sure if Bluetooth is installed and running please check with your system administrator to verify if Bluetooth is supported on your computer system.

Installed drivers show a white on blue B-Icon in the system tray on the right bottom side of the desktop (Taskbar). Some Notebooks have separate pushbuttons to switch it on/off.



If Bluetooth is already supported you can go directly to Step 3-B Setting up HVA28TD Communication (Windows supported). If your system uses a different driver as shown in this manual, use the above mentioned parameters to set up Communication.

### Step 1 Installation of Bluetooth support on your computer

If your computer does not have a built in or existing Bluetooth Hardware you can use the Bluetooth Dongle and CD which is shipped with your HVA28TD System. This dongle has been tested to work with the HVA28TD unit and has a range of approximately 50 feet / 15 meters.

**DO NOT INSTALL THE BLUE TOOTH DONGLE BEFORE INSTALLING THE DRIVERS AS DESCRIBED BELOW.**

#### Start Installation

Start the installation process by inserting the driver CD supplied. The Setup should start automatically, if not locate the CD/DVD drive on "My Computer" and start Setup.exe in the driver folder.

Due to possible technological changes in drivers and the Windows operating system, certain messages shown below may vary slightly to what you may find on your computer.



Driver Setup Start Screen



Accept License agreement

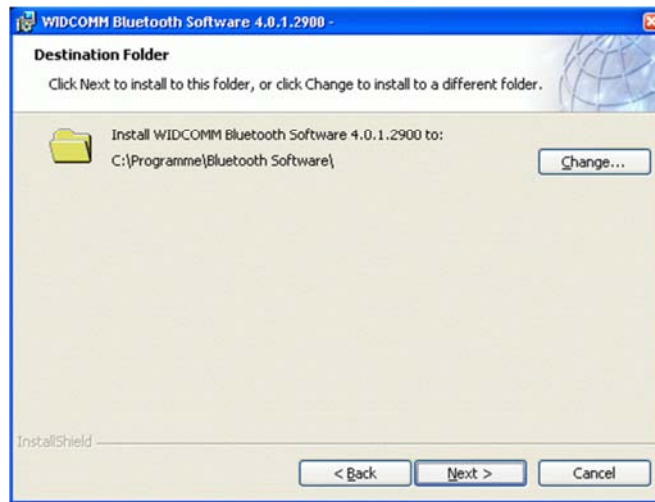

*Choose Driver Software Destination. We suggest using the defaults.*

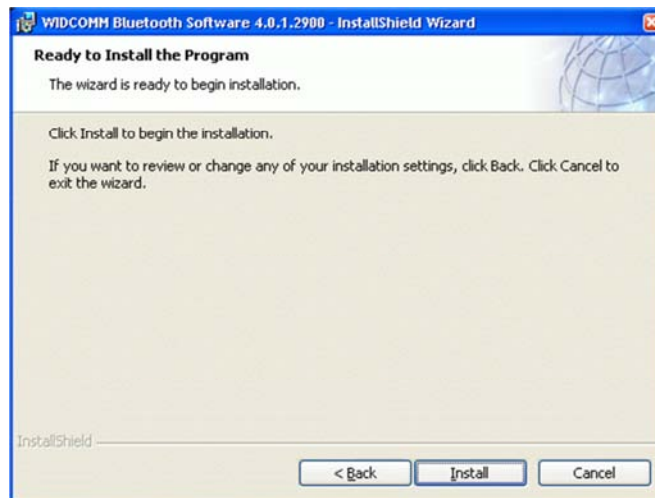

*Begin Installation*

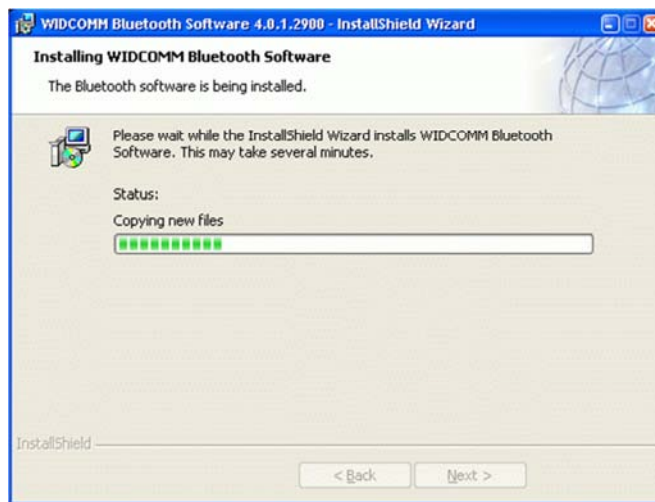

*Installation has started*

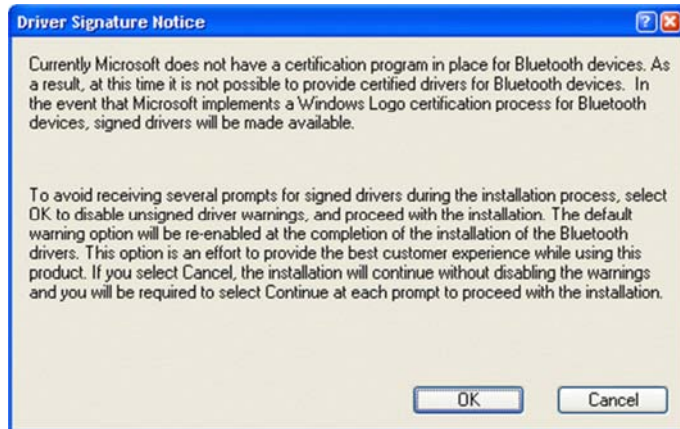

*Press OK to accept this driver*



*The driver now needs to have the Bluetooth dongle inserted.  
 Plug the dongle into a free USB port. The windows Hardware Installation  
 will now run and some further information windows will appear.  
 Please wait until the Hardware Detection has finished.  
 This screen will then disappear automatically*



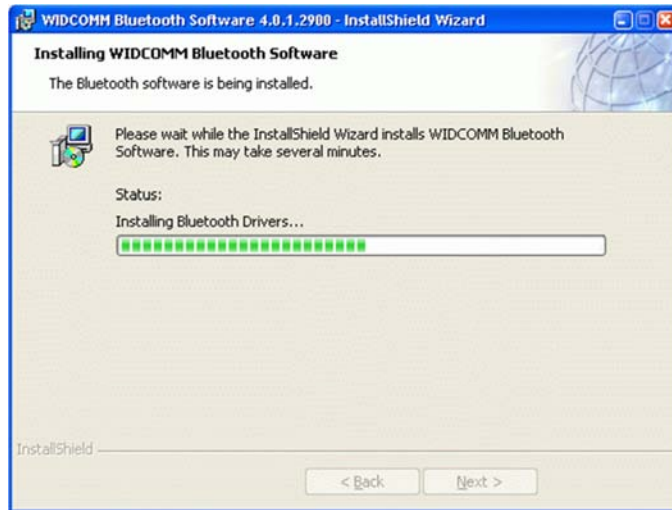

*Installation of Bluetooth support on your Computer. Other information messages may appear. Please wait until the Installation completes.*

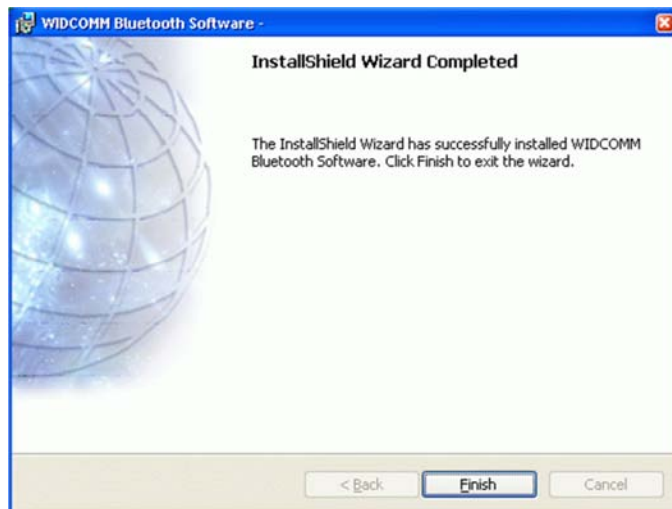

*Installation of Bluetooth support finished.*

*The above mentioned white on Blue "B"-Bluetooth icon now appears in the system tray.*

## Step 2 Configure Bluetooth Support (First Time Users)

After successful driver installation a white on blue Bluetooth icon appears in the system tray on the right bottom side of your desktop and a new Icon “My Bluetooth Places” appears on your desktop:



### Configure Bluetooth Support using external dongle

Please follow this instruction to set up a communication port to the HVA28TD system if you are using the external dongle with the above mentioned driver (not windows built in support).

### First usage configuration

After the new installation of the Bluetooth support on your computer, you have to configure the type of service your computer uses.

Double click on the Bluetooth icon in the system tray or the “My Bluetooth Places” icon on your desktop to bring up the configuration wizard:



*Initial Bluetooth configuration (only has to be done once)*

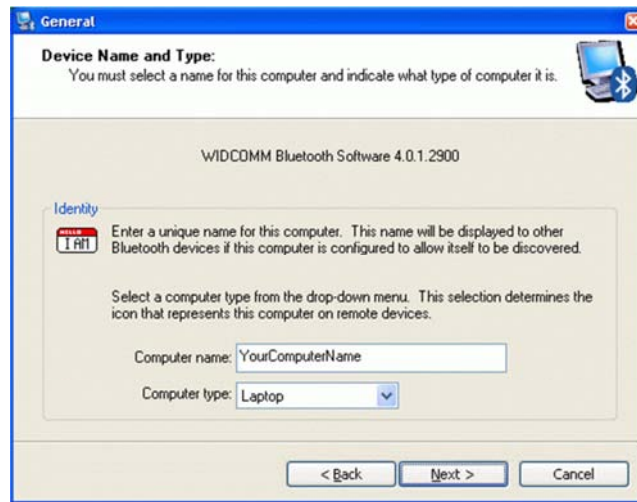

Type in the name and type of your computer



Start Configuration

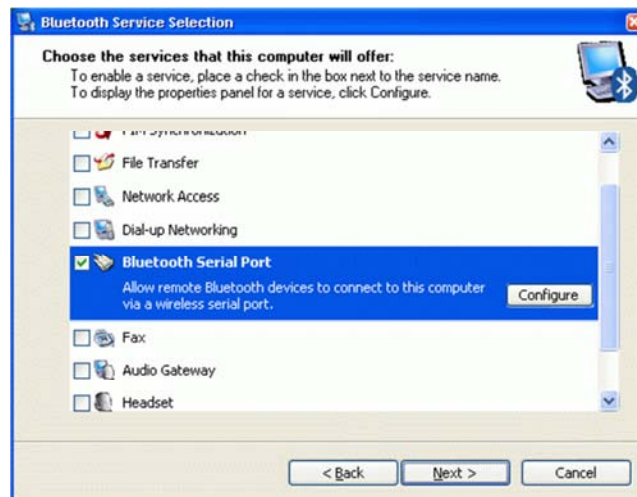

Check or uncheck those Bluetooth services you want to use.

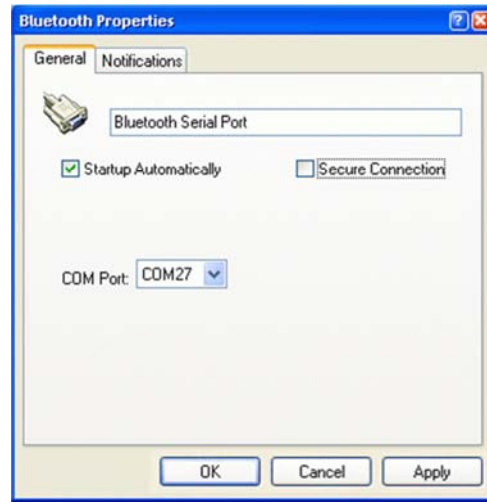

Bluetooth Serial Port Configuration. Leave as suggested. Take note of the serial port number.



Press Skip to tell the system that you will connect to the HVA28TD system at a later stage.



Finished Initial Setup of Bluetooth Support.

### Step 3-A: Setting up a HVA28TD Communication Port (External Dongle)

After installation and configuration of the Bluetooth drivers and hardware dongle, an icon called “My Bluetooth Places” gives you access to all Bluetooth specific properties and configurations.

All configured devices are listed under the “My Bluetooth Places”.



#### Switch on the TD system

Before connecting, reset the HVA28TD System by switching the main power switch off and then ON again.

Make sure the HVA28TD system is within 50 foot / 15 meters of the connecting computer. Since the Bluetooth RF signals can be affected by other wireless systems and obstructions such as WLAN or other RF devices, try moving the HVA28TD system closer to your computer if you cannot get a “pairing” connection from following the procedure below.

#### Setup the Communication Port to connect to the HVA28TD

Start to set up a communication port to the HVA28TD system by double-clicking on the “My Bluetooth Places” icon.

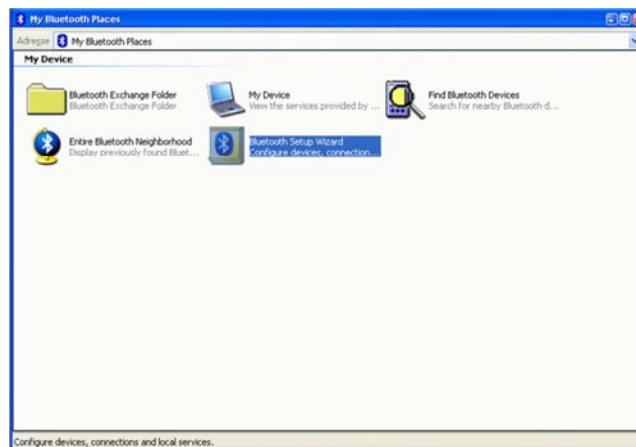

*My Bluetooth Places:  
Select Bluetooth Setup Wizard to connect to HVA28TD system.*



Select "I want to find a specific Bluetooth device ..." to find the HVA28TD system



All available Bluetooth devices are listed.  
HVA28TD systems are shown with the last 6 digits of the Serial number.  
Select the HVA28TD unit you want to connect to.



Pair the device. Type in the PIN code "welcome" and press "Initiate Pairing".  
A message "No Com port available" may be appear. Just quit with ok.

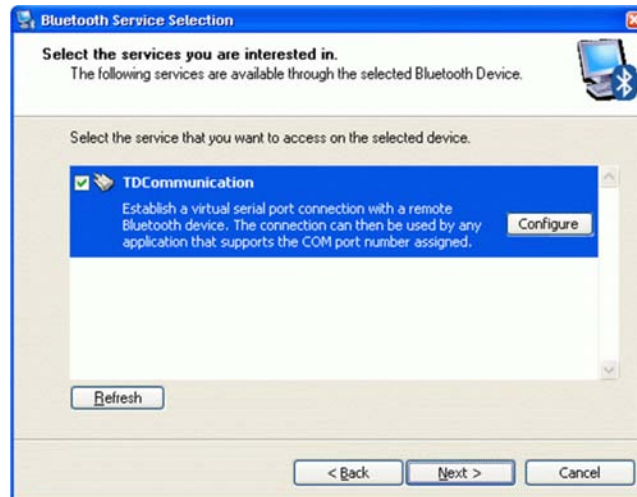

Check the "HVA28TD Communication" service to use. A message to configure the port will appear.

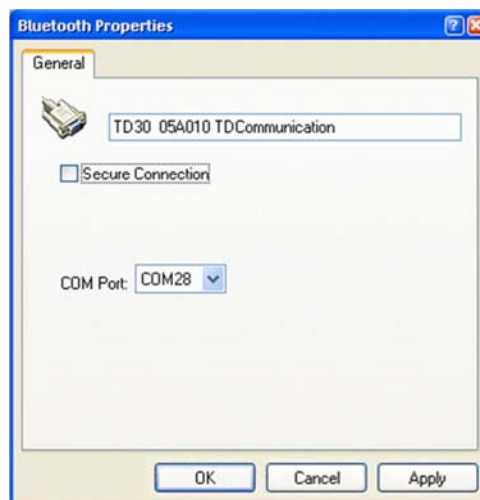

Leave default setting for this port. Make note of it. You can use either Secure or Unsecured Connection.



Successful Setup of communication port!

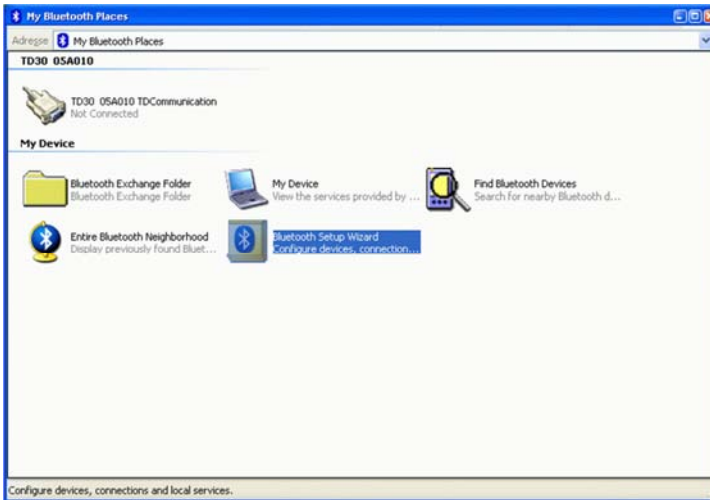

The HVA28TD system is now shown as an icon in "My Bluetooth Places"

### Initial Connection to the HVA28TD unit (Establish and Test connection)

To establish the connection and to fix the settings of the COM-port you have to perform an initial connection to the HVA28 TD unit. This is also verifies a correct setup.

Double click the HVA28TD System icon.

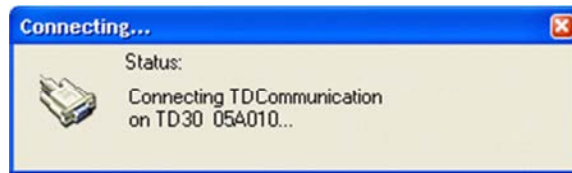

Connecting to the HVA28TD System



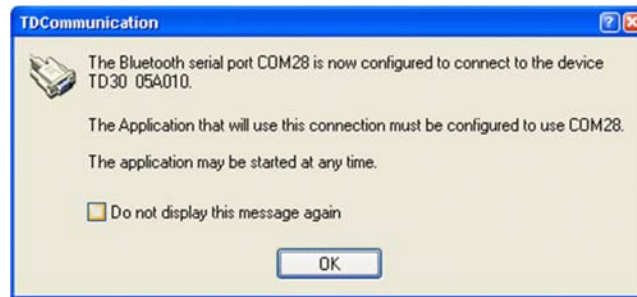

*Established Connection!*

*Read the information and note the COM-Port Number.*

*This number is used by the TD ControlCenter to communicate with the HVA28TD unit.*

*You can use the 3rd page of the manual to write down this*

*Configuration number for later reference purposes.*

### **Close (disconnect) the Test connection**

Right click on the HVA28TD System icon and select Disconnect.



*Disconnecting*

It is also possible to switch off the HVA28TD system and the connection will automatically be closed.

**The System is now configured and you can start working with the TD ControlCenter. You will use the given COM-Port number to set in the ControlCenter and press the connect button.**

### Step 3-B: Setting up a HVA28TD Communication Port (Windows Supported)

If your Windows operating System already supports your Bluetooth Hardware you can use the Windows Bluetooth System instead of a separate driver to set up the communication.

Windows shows you the Bluetooth icon in the System Tray on the right bottom side of your desktop. This gives you access to all Bluetooth specific properties and configurations.



#### Switch on the TD system

Before connecting, reset the HVA28TD System by switching the main power switch off and on.

Make sure the HVA28TD system is within the range of 50 feet / 15 meters to the computer. Internal integrated Bluetooth devices often have closer working ranges than external. So you maybe have to reduce the distance to get good connectivity.

#### Setup the Communication Port

Start to set up and allocate a communication port to the HVA28TD system by double-clicking on the Bluetooth icon in the system tray.

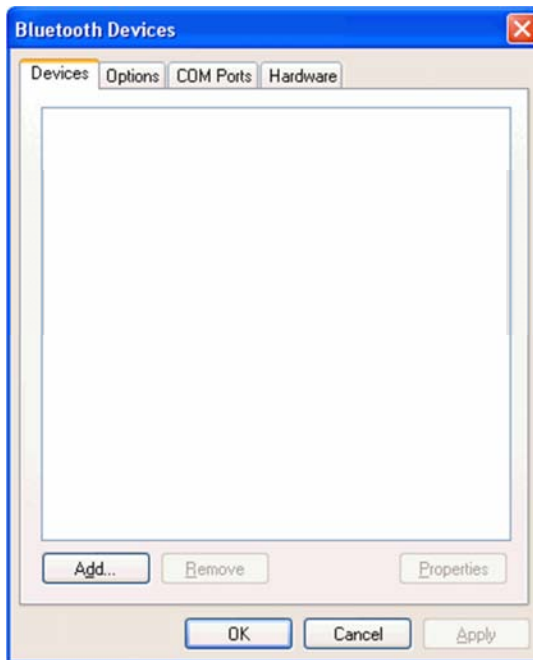

*Bluetooth Devices, press Add to start*



*Check Device is switched on and ready to discover*



*All available Bluetooth devices are listed.  
HVA28TD systems are shown with the last 6 digits of the Serial number.  
Select the HVA28TD unit you want to connect to.*

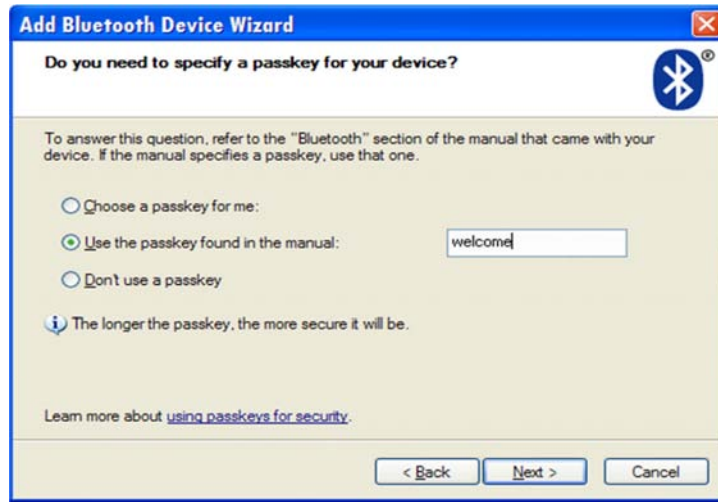

Select "Use Passkey from documentation" and enter "welcome" to use as key



Windows connects to the HVA28TD System and installs the relevant drivers.



*Read the information and note the “outgoing/outbound” COM-Port Number. This number is used by the TD ControlCenter to communicate with the HVA28TD unit. You can use the 3rd page of the manual to write down this Configuration Com Port number for later reference purposes.*

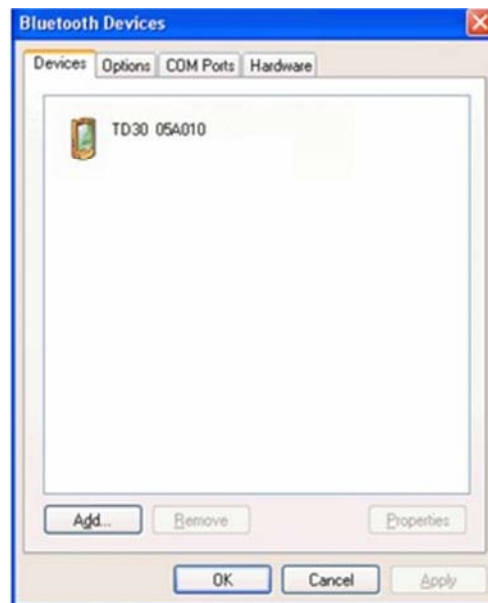

*The System is now configured.*

You can start working with the TD ControlCenter.  
Use the given COM-Port number in the TD ControlCenter and press the connect button.

## 7 Reporting

### Report Type

The HVA28TD can generate one report type: “Basic” report with limited information.

See 4.3: Instrument Set-up

| Report Info.            | Basic |
|-------------------------|-------|
| DUT Type                | ✓     |
| Voltage Rating          | ✓     |
| (Cable) Insulation Type | ✓     |
| Report Title            | ✓     |

### Report Activation

Every Test will be reported. You have to Title the Report before Starting a Test.

### Report Naming Instructions

To enter the report information, some steps require the operator to enter a user selected name. If no name is entered, the corresponding category appears blank in the report.

Possible entries include:

- A B C D E F G H I J K L M N O P Q R S T U V W X Y Z
- ( ) - :
- 0 1 2 3 4 5 6 7 8 9

**Situation**

Activate Naming



**Procedure**

To select characters: Rotate Knob (5) then Push in / "Click"

Delete



To DELETE: Rotate Knob (5) on the "<<" Button and Push in / "Click"





Confirm



To CONFIRM: Rotate Knob (5) on the "OK" Button and push in / "Click"

## Viewing Report

Reports can be viewed directly on the HVA28TD display and you can export it on a USB Flash Drive.

| Situation  | Procedure  |
|--|--|
| <p>Reports</p>          | <p>Open "Reports"</p>  |
| <p>Reports List</p>    | <p>All Reports are listed.</p>                                     |
| <p>Choose Report</p>  | <p>Choose one of the reports.</p>                                  |
| <p>View Report</p>    | <p>Select "View" for viewing the Report on the HVA28TD screen.</p> |



**Situation**

Save Report on USB



**Procedure**

Select "> USB" to store the selected Report on the USB Flash Drive.

Delete a Report



Select "Delete" to delete the selected Report.

Delete all Reports



Select "Delete all" to delete ALL Reports from the Report List.

## 8 Disconnection Procedure



### DANGER

#### Electric Shock Hazard

Never assume that equipment is safe to handle without using the necessary safety equipment and grounding procedures.

**Disconnection procedures must comply with local safety regulations.**



- Before disconnecting test lead, DUT must be discharged and grounded.
- Ground connections must be removed last!

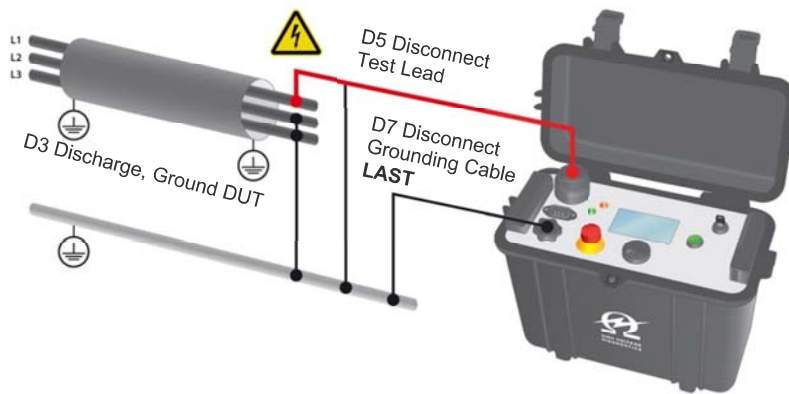

### Disconnection



### Normal Conditions

Steps **D 1- D 8** describe the **normal disconnection** procedure.

| Step   | Procedure (Normal Disconnection)  |
|--|---|
| D1  | Press Emergency OFF (1)   |
| D2  | Verify HV status <ul style="list-style-type: none"> <li>• Wait until LED red (3) light deactivates (indicates residual voltage &lt; 100V)</li> </ul>                                  |
| D3   | Discharge and ground the DUT complying with local safety regulations  |
| D4  | Lock HVA in disabled state to prevent against unauthorized use: <ul style="list-style-type: none"> <li>• Turn Key switch (7) to OFF Position and remove Key</li> </ul>                |
| D5   | Disconnect the Test Lead <ul style="list-style-type: none"> <li>• Disconnect the test lead from the DUT</li> <li>• Unscrew the test lead from the HV output connector (11)</li> </ul> |

| Step   | Procedure (Normal Disconnection)   |
|--|--|
| D6  | Disconnect power supply cable from power supply plug (9)   |
| D7  | Disconnect Ground <ul style="list-style-type: none"> <li>• Disconnect the grounding cable from the HVA grounding connector (10)</li> <li>• Disconnect the grounding cable from the DUT.</li> </ul> |

### System Failure

In case of errors or failure due to a loss of power during testing, additional precaution is required. The HVA LED red (3) light cannot indicate when residual voltage is less than 100V. To guarantee that the residual voltage has dissipated before removing the test lead, the DUT must be de-energized using a discharge stick.

Steps **D 1\*-D 7\*** describe the **disconnection** procedure in case of **system failure**.

| Step | Procedure (System Failure Disconnection)   |
|------|--|
| D1*  | Switch HVA OFF <ul style="list-style-type: none"> <li>• Press Emergency OFF (1)</li> <li>• Turn the HVA main switch (8) off</li> <li>• Lock HVA in disabled state to prevent against unauthorized use: Turn Key switch (7) to OFF Position and remove Key</li> </ul>   |
| D2*  | <ul style="list-style-type: none"> <li>• Verify correct functioning of discharge stick</li> </ul>  |
| D3*  | Discharge and ground the DUT complying with local safety regulations <ul style="list-style-type: none"> <li>• Discharge DUT using a discharge stick</li> </ul>   |
| D4*  | Before disconnecting test lead, <b>wait</b> until residual voltage has dissipated. <ul style="list-style-type: none"> <li>• Required wait time depends on the resistance of the discharge stick. (A)</li> <li>• Rule of thumb: For standard discharge sticks, wait a minimum of 20 seconds afterwards ground the cable immediately.</li> </ul> |
| D5*  | Disconnect the Test Lead <ul style="list-style-type: none"> <li>• Disconnect the test lead from the DUT</li> <li>• Unscrew the test lead from the HV output connector (11)</li> </ul>  |
| D6*  | Disconnect power supply cable from power supply plug (9)   |
| D7*  | Disconnect Ground <ul style="list-style-type: none"> <li>• Disconnect the grounding cable from the HVA grounding connector (10)</li> <li>• Disconnect the grounding cable from the DUT.</li> </ul>   |



## 9 Instrument Care

### Cleaning



**DANGER**

**Electric Shock Hazard!**

Only clean the instrument when turned off!

HV Cable

Clean the HV Cable connection points, after use, before storing



### Storage



**CAUTION**

**Instrument Damage**

Do not store the HVA28TD outdoors!  
Keep the HVA28TD away from liquids!

HVA should be stored indoors in the following environmental conditions:

- Temperature: -25°C to 70°C (-13°F to 158°F)
- Humidity: 5-85% non-condensing

### Maintenance and Repairs



**NOTICE**

**Authorized personnel only!**

Repairs and maintenance should only be performed by authorized HV Diagnostics personnel.



One yearly inspection by authorized HV Diagnostics personnel is recommended.

## 10 Glossary and Abbreviations

The following explains abbreviations and selected terms used in this document in alphabetical order.

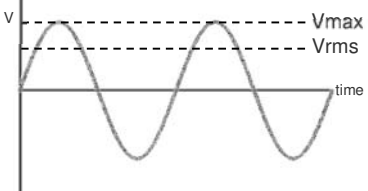
| Term                                   | Explanation   |
|--|---|
| Arc                                    | Self-maintained gas conduction for which most of the charge carriers are electrons supplied by primary-electron emission (source: IEC)  |
| Auto Adjust Frequency<br>"0.1 Hz/Auto" | Mode that maximizes output frequency to highest allowable value <ul style="list-style-type: none"> <li>• Greatest allowable frequency depends on the test load and test voltage applied</li> <li>• For loads greater than 1<math>\mu</math>F, the instrument automatically reduces the frequency</li> </ul> |
| DUT                                    | Device under Test   |
| Duty (continuous)                      | Load state in which the relay remains energized for a period long enough to reach thermal equilibrium   |
| Fault                                  | An unplanned occurrence or defect in an item which may result in one or more failures of the item itself or of other associated equipment (source: IEC)   |
| Frequency[Hz]                          | Number of cycles per unit of time ; $f=1/$ Period (Time), units=Hz<br>1Hz = 1cycle / 1 second<br>0.1 Hz = 1cycle / 10 second, etc.  |
| Hipot                                  | High potential (voltage)  |
| HV                                     | High Voltage (tension) <ul style="list-style-type: none"> <li>• Extremely high voltage: typically 220kV or 380kV</li> <li>• High voltage: typically 110kV</li> </ul>  |
| IEC                                    | International Electrotechnical Commission   |
| Peak value                             | Maximum Voltage = $V_{max}$   |
| RMS value                              | Root Mean Square voltage <ul style="list-style-type: none"> <li>• <math>V_{rms} = V_{max} / \sqrt{2}</math></li> </ul>  |
|  |    |
| To Short                               | Forcing the electric potential differences between two or more conductive parts to be equal to or close to zero (Infinite current flows in a short circuit)   |
| To Trip                                | Opening the circuit (no current flows in open circuit)  |
| VLF                                    | Very Low Frequency <ul style="list-style-type: none"> <li>• Typically between 0.01 -0.1 Hz</li> </ul>   |

## 11 Declaration of Conformity

The HVA28TD is CE certified and has met the following requirements of the European Council:

| Category | Standard  |
|----------|---|
| EMC      | IEC61004-2 , ESD Level 4 (8/15kV)<br>IEC61004-4 , Burst 4kV 5kHz<br>EN55011 |
| Safety   | EN60950<br>EN50191<br>EN61010-1   |