

CP TD1

Reference Manual



Article Number: VESD0606 Manual Version: CPC100TD1.AE.6

© OMICRON electronics 2012. All rights reserved.

This manual is a publication of OMICRON electronics GmbH.

All rights including translation reserved. Reproduction of any kind, for example, photocopying, microfilming, optical character recognition and/or storage in electronic data processing systems, requires the explicit consent of OMICRON electronics. Reprinting, wholly or in part, is not permitted.

The product information, specifications, and technical data embodied in this manual represent the technical status at the time of writing and are subject to change without prior notice.

We have done our best to ensure that the information given in this manual is useful, accurate and entirely reliable. However, OMICRON electronics does not assume responsibility for any inaccuracies which may be present.

The user is responsible for every application that makes use of an OMICRON product.

OMICRON electronics translates this manual from the source language English into a number of other languages. Any translation of this manual is done for local requirements, and in the event of a dispute between the English and a non-English version, the English version of this manual shall govern.

Contents

	Using this Manual	7
	Safety Rules	9
1	Introduction	15
1.1	Designated Use	15
1.2	Functional Components of the <i>CPC 100</i> and <i>CP TD1</i>	16
1.3	Functional Components of the <i>CP TD1</i>	18
1.3.1	Grounding Terminal and Booster Input	18
1.3.2	Serial Interface Connector and Measuring Inputs	18
1.3.3	High-Voltage Connector	19
2	Operation	21
2.1	Measurement Setup	21
2.1.1	Setup of Devices with Trolley	21
2.1.2	Setup of Devices without Trolley	21
2.2	<i>CP TD1</i> Connected to a Test Object	22
2.3	<i>CP TD1</i> Connected to <i>CP CAL1</i>	23
2.4	Calibrating the <i>CP TD1</i> Using a Reference Capacitor	23
2.4.1	Calibration Tips	24
3	Test Cards	25
3.1	TanDelta Test Card - Main Page (1/2)	25
3.2	TanDelta Test Card - Main Page (2/2)	28
3.3	TanDelta Test Card - Settings Page (1/2)	29
3.4	TanDelta Test Card - Settings Page (2/2)	30
3.5	Templates	31
4	Application	33
4.1	Preparations in Substation	33
4.2	Connection	33
4.3	Measurement	35
4.4	Disconnection	36
5	Capacitance and Dissipation Factor Measurement	39
5.1	Theory	39

5.2	Measurement of Capacitance and Dissipation Factor / Power Factor	54
5.3	"UST" and "GST" Measurements Using the Guard Technology	58
5.4	References	63
6	Power Transformers	65
6.1	Introduction	65
6.2	Capacitance and DF Measurement of Transformer Windings.	70
6.2.1	Three-Winding Transformer	72
6.2.2	Two-Winding Transformer	85
6.2.3	Auto-Transformer	87
6.2.4	Reactors	88
6.3	Transformer High-Voltage Bushing Tests	88
6.4	Interpretation of Measurement Results	88
6.4.1	Dissipation Factor Measurement	88
6.4.2	Capacitance Measurement	89
6.5	References	89
7	Capacitance and DF Measurement on High-Voltage Bushings.	91
7.1	Introduction	91
7.2	Types of Bushings	91
7.3	Bushing Troubles.	94
7.4	Capacitance and DF Measurement on High-Voltage Bushings.	96
7.5	Ungrounded Specimen Test (UST)	97
7.6	Grounded Specimen Test (GST)	99
7.7	Hot Collar Test.	99
7.8	Interpretation of Measurement Results	104
7.9	References	107
8	Capacitance and DF Measurement of Generators and Motors	109
9	Capacitance and DF Measurement of Circuit Breakers	111
9.1	Introduction	111
9.2	Oil Circuit Breakers (Dead Tank)	111
9.3	Oil Poor Circuit Breakers (Live Tank)	112
9.4	SF6 Circuit Breakers (Dead Tank with Bushings)	112
9.5	Vacuum Circuit Breakers	112
9.6	Air Magnetic Circuit Breakers	113
9.7	Oil Circuit Reclosers	113

10	Capacitance and DF Measurement of Overvoltage Arresters	115
11	Technical Data	119
11.1	Technical Data of the <i>CP TD1</i> in Combination with the <i>CPC 100</i>	119
11.1.1	High-Voltage Output	119
11.1.2	Measurements	119
11.2	Environmental Conditions	123
11.3	CE Conformity and Safety Standards	124
11.4	Cleaning	124
11.5	Accessories	125
11.5.1	Cables and Clamps	125
11.5.2	Optional Accessories	126
11.6	Ordering Information	127
12	Appendix	129
12.1	Parallel and Serial Equivalent Circuit Diagrams	129
12.2	Negative DF Measurements	130
12.3	Two- and Three-Winding Transformer Tests (IEEE C57.12.90)	132
12.4	Limits for Test Voltages for C2 Testing on Bushings	133
12.5	C2 Measurement on High-Voltage Bushings	133
12.5.1	Abstract	133
12.5.2	Introduction	134
12.5.3	Design/Construction of C1 and C2 Capacitance in Condenser Bushings	134
12.5.4	Factors Affecting C1, C2 Capacitance and Power Factor Measurements	136
12.5.5	Conclusions	140
12.5.6	Biography	141
12.5.7	References	141
12.6	DF Limits of RBP Bushings (Micafil AG)	142
12.7	DF Limits of Bushings (B)	143
12.8	DF Limits of Bushings (C)	144
12.9	Transformer Diagnosis	146
12.9.1	Introduction	147
12.9.2	Methods of Analysis	149
12.9.3	Fault Localization	150
12.9.4	Winding Resistance Measurement and On-Load Tap Changer Test	151
12.9.5	Four-Wire Connection for Transformer Winding Resistance Measurement	155
12.9.6	Safety Aspects	156
12.9.7	Delta-Connected Windings	157

12.9.8 Winding Resistance Measurement of a 100 MVA Transformer	158
12.9.9 Dynamic Behavior of the Diverter Switch	162
12.9.10 Turns Ratio	163
12.9.11 Excitation Current	165
12.9.12 Leakage Reactance	166
12.9.13 Capacitance and DF Measurement	169
12.9.14 DF Measurements on Transformer Windings	174
12.9.15 Capacitance Measurements on Transformer Windings	175
12.9.16 Capacitance and DF Measurements on Transformer Bushings	175
12.9.17 Summary	179
12.10References	180
12.11Temperature Correction Factors	181
12.11.1 Transformers	181
12.11.2 Bushings	182
OMICRON Service Centers	185
Index	187

Using this Manual

This User Manual provides information on how to use the *CP TD1* safely, properly and efficiently. The *CP TD1* Reference Manual contains important safety rules for working with the *CP TD1* and gets you familiar with operating the *CP TD1*. Following the instructions in this Reference Manual will help you to prevent danger, repair costs and possible down time due to incorrect operation.

The *CP TD1* Reference Manual always has to be available on the site where the *CP TD1* is used. It must be read and observed by all users of the *CP TD1*.

Reading the *CP TD1* Reference Manual alone does not release you from the duty of complying with all national and international safety regulations relevant to working on power transformers.

Operator Qualifications and Safety Standards

Working on high-voltage assets can be extremely dangerous. Testing with the *CP TD1* must be carried out only by qualified, skilled and authorized personnel. Before starting to work, clearly establish the responsibilities.

Personnel receiving training, instructions, directions, or education on the *CP TD1* must be under constant supervision of an experienced operator while working with the equipment.



Testing with the *CP TD1* must comply with the internal safety instructions as well as additional relevant documents.

In addition, observe the following safety standards, if applicable:

- EN 50191 (VDE 0104) "Erection and Operation of Electrical Equipment"
- EN 50110-1 (VDE 0105 Part 100) "Operation of Electrical Installations"
- IEEE 510 "IEEE Recommended Practices for Safety in High-Voltage and High-Power Testing"

Symbols Used

In this manual, the following symbols indicate paragraphs with special safety relevant meaning:

Symbol	Description
	Caution: Equipment damage or loss of data possible
	Warning: Personal injury or death of the operating staff or severe damage to objects possible

General

Always observe the five safety rules:

- Disconnect completely
- Secure from reconnection
- Verify that the installation is dead
- Carry out grounding and short-circuiting
- Provide protection against adjacent live parts

Safety Rules

Before operating the *CP TD1*, read the following safety rules carefully. If you do not understand some safety rules, contact OMICRON electronics before proceeding.

Maintenance and repair of the *CP TD1* is only permitted by qualified experts at OMICRON electronics repair centers.

Operating the Measurement Setup

Only personnel qualified in electrical engineering and trained by OMICRON electronics are authorized to operate the *CP TD1*. Before starting the work, clearly establish the responsibilities.

Personnel receiving training, instructions, directions, or education on the *CP TD1* must be under constant supervision of an experienced operator while working with the equipment.

The operator is responsible for the safety requirements during the whole test.



Warning: Do not enter the high-voltage area if the red warning light of the *CPC 100* is on since all outputs carry dangerous voltage or current! Always obey the five safety rules and follow the detailed safety instructions in the respective user manuals.

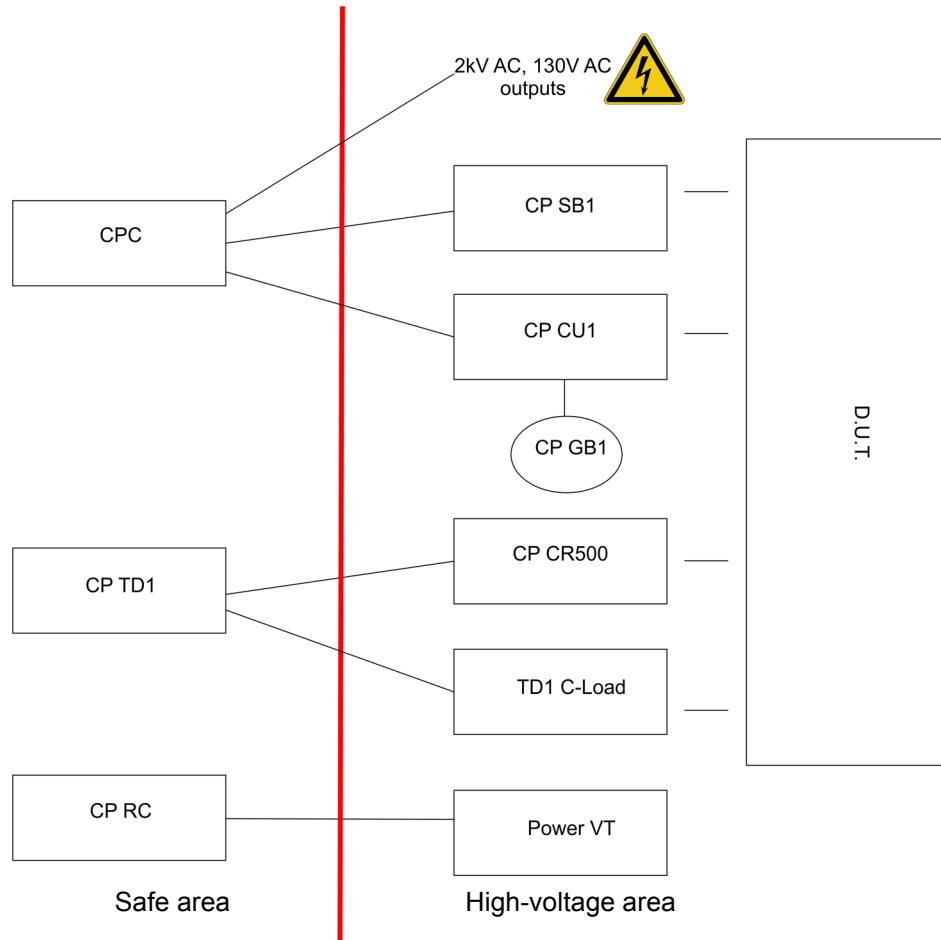

Figure 1-1 Example for the separation of safe and high-voltage area using different OMICRON electronics devices

Before performing tests using high voltage, observe the following instructions:

- Do not use the test equipment without a good connection to substation ground.
- Do not insert objects (for example screwdrivers, etc.) into any input/output socket.
- Do not operate the *CP TD1* under ambient conditions that exceed the temperature and humidity limits listed in 11.2 "Environmental Conditions" on page 123.
- Make sure to position the test equipment on dry, solid ground.
- Do not operate the *CP TD1* in the presence of explosives, gas or vapors.
- Opening the *CP TD1* invalidates all warranty claims.
- Do not use an extension cable on a cable reel to prevent an overheating of the cord; run out the extension cord.
- If the *CP TD1* does not seem to function properly, do not use it anymore. Please call the OMICRON electronics technical support.

Handling Cables

- Always turn off the *CP TD1* completely before you connect or disconnect any cable (disconnect the *CPC 100* from mains or press its Emergency Stop button).
- The high-voltage cable must always be well attached and tightly connected to both the *CP TD1* and the test object. A loose or even falling off connector at the test object carrying high-voltage is life-hazardous. Make sure the connectors are clean and dry before connecting.

At the *CP TD1*, press the high-voltage cable's plug to the connector tightly and turn the screw cap until you feel a mechanical stop. If you notice a rough-running of the screw-cap, clean the screw thread and use a lubricant (vaseline recommended).

At the test object, insert the high-voltage cables' plugs carefully until you feel a "click" position. Now they are locked. Confirm this by trying to pull them out. This should not be possible now.

Note: Tighten the plugs manually. Do not use any tools for that because that can damage the plugs or connectors.

Insert the yellow banana plug (the high-voltage cable's grounding) into the respective plug socket.

- Do not connect any cable to the test object without a visible grounding of the test object.
- The high-voltage cable is double-shielded and therefore safe. However, the last 50 cm (20 inch) of this cable have no shield. Therefore, during a test consider this cable a live wire and due to the high-voltage life-hazardous!



Warning: When the *CPC 100* is switched on, consider this part of the cable has to be in the high-voltage area due to a hazard of electric shock!

- Never remove **any** cables from the *CP TD1* or the test object during a test.
- Keep clear from zones in which high voltages may occur. Set up a barrier or establish similar adequate means.
- Both low-voltage measuring cables must always be well attached and tightly connected to the *CP TD1*'s measuring inputs IN A and IN B.

Make sure to insert the red and blue marked cables into the corresponding measuring inputs: IN A = red, IN B = blue.

Tighten the plugs by turning them until you feel a stop.

Note: Tighten the plugs manually. Do not use any tools for that because that can damage the plugs or connectors.

Do not use any other cables than the ones supplied by OMICRON electronics.

Orderly Measures

The *CP TD1* Reference Manual or alternatively the e-book in PDF format has always to be available on site where the *CP TD1* is being used. It must be read and observed by all users of the *CP TD1*.



Warning: The *CP TD1* may be used only as described in this Reference Manual. Any other use is not in accordance with the regulations.

The manufacturer and/or distributor is not liable for damage resulting from improper usage. The user alone assumes all responsibility and risk.

Following the instructions provided in this User Manual is also considered part of being in accordance with the regulations.

Disclaimer

If the equipment is used in a manner not specified by the manufacturer, the protection provided by the equipment may be impaired.

Static Charges

Static charges on bushings or other apparatus such as transformer windings may be induced by test potentials. While the voltage may not be significant enough to do any damage, it can be a source for serious accidents due to falls caused by reflex action.

High static charges may also be encountered at the bushing capacitance taps if the covers are removed. Also, you should use safety grounds before handling.

Note: Always observe the five safety rules!

1 Introduction

1.1 Designated Use

The *CP TD1* is an optionally available high-precision test system for on-site insulation tests of high-voltage systems like power and measuring transformers, circuit breakers, capacitors and isolators. With the add-on device *CP TD1*, the *CPC 100* increases its range of possible applications into high-voltage measurements.

The internal switched mode power amplifier enables measuring at different frequencies without interferences with the mains frequency. Automatic test procedures reduce the testing time to a minimum. Test reports are generated automatically.

The *CP TD1* comes with its own test card named **TanDelta** (Tangent Delta), which provides highly accurate measurements of the capacitance C_x and the dissipation factor $\tan \delta$ (DF) or power factor $\cos \varphi$ (PF), respectively.

Both the dissipation factor and the power factor grant information about possible losses in the insulation material, which are increasing with age and water content. A change of C_x is a warning indicator for partial breakdowns between the layers of a bushing or a capacitor.

Additionally, the *CP TD1* measures the following quantities:

- Actual, apparent and reactive power
- Quality factor QF
- Inductance
- Impedance, phase angle
- Test voltage & current

The *CP TD1* works as an add-on device to the *CPC 100*. Do not connect the *CP TD1* to any other device. Do not use the accessories for applications not indicated in this user manual.

Any other use of the *CP TD1* but the one mentioned above is considered improper use, and will not only invalidate all customer warranty claims but also exempt the manufacturer from its liability to recourse.

1.2 Functional Components of the *CPC 100* and *CP TD1*

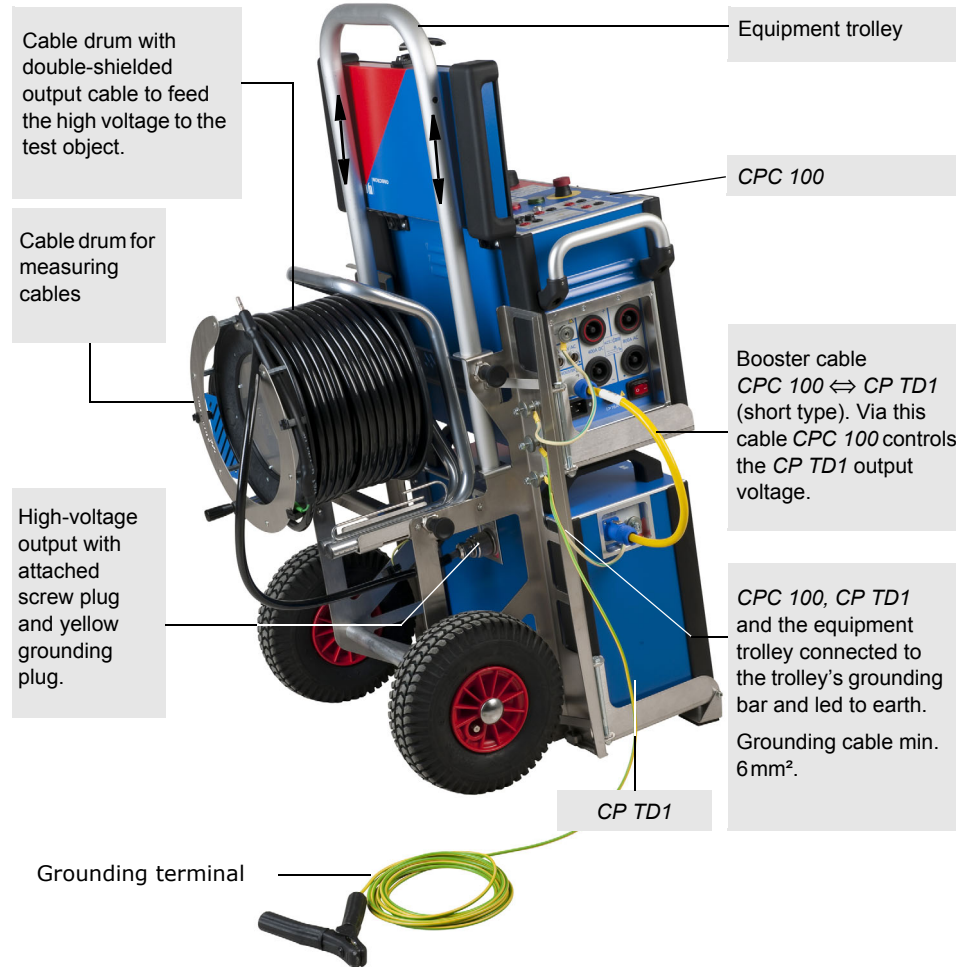



1.3 Functional Components of the *CP TD1*

1.3.1 Grounding Terminal and Booster Input

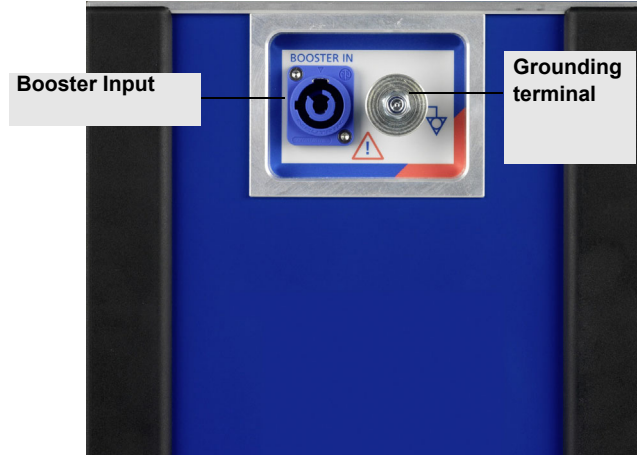

Figure 1-2 Grounding terminal and booster input of the *CP TD1*

1.3.2 Serial Interface Connector and Measuring Inputs

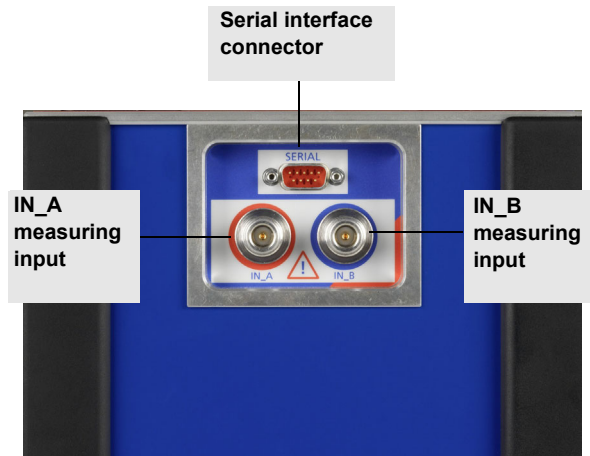

Figure 1-3 Serial interface and measuring inputs of the *CP TD1*

1.3.3 High-Voltage Connector

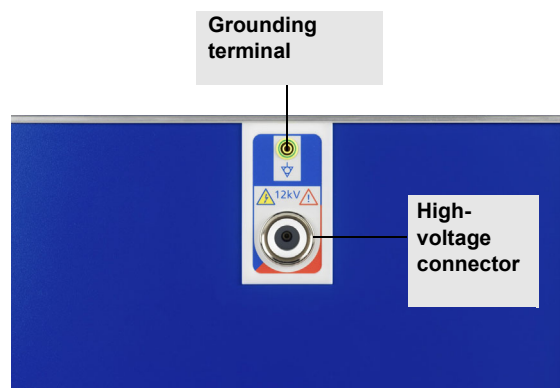

Figure 1-4 High-voltage connector of the *CP TD1*

2 Operation

2.1 Measurement Setup

2.1.1 Setup of Devices with Trolley

The equipment trolley holds the *CPC 100*, *CP TD1* and all required cables. The trolley is equipped with a grounding bar with three knurled screws to ensure a solid connection to the grounding terminals of all devices.

2.1.2 Setup of Devices without Trolley

If the *CPC 100* and *CP TD1* are to be operated without trolley, place them on their transport cases and connect them with the long type data cable *CPC 100* ⇔ *CP TD1* (3m) and the long-type booster cable *CPC 100* ⇔ *CP TD1* (3m). Each device has to be grounded separately with a 6m grounding cable of at least 6mm².

2.2 CP TD1 Connected to a Test Object

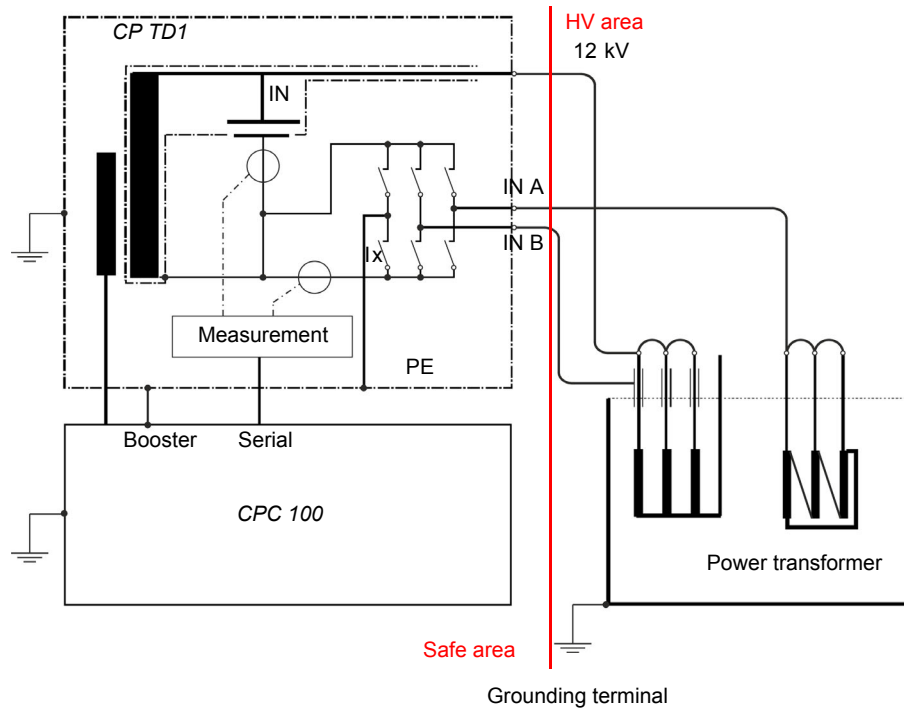

2.3 CP TD1 Connected to CP CAL1

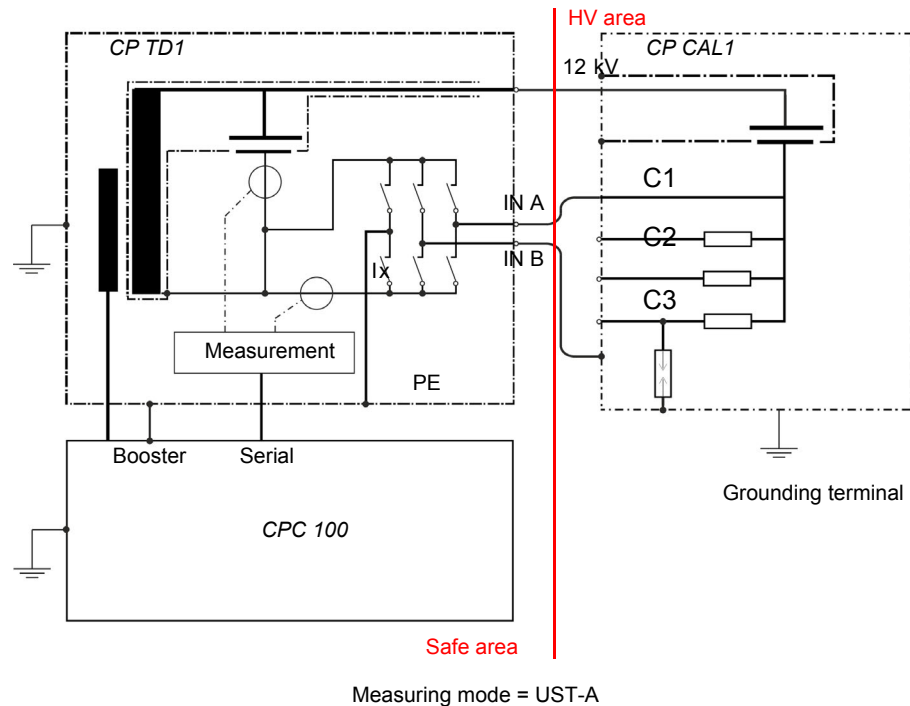

When using the *CP CAL1* for calibration, we recommend to take C1 as reference and to select the calibration frequency in a range between 50 ... 200Hz.

2.4 Calibrating the CP TD1 Using a Reference Capacitor



Warning: For using the *CP CAL1*, make sure to apply the same procedure as described in this Reference Manual.

By connecting a reference capacitor (e.g., optional device *CP CAL1*) with known values of capacity C_{ref} and dissipation factor DF_{ref} , in mode UST-A the values C_x and DF_x can be measured and then compared to the known reference values.

If you experience substantial deviations, re-calibrate the *CP TD1*:

- $C_x = C_{ref} / C_{meas}$ and
- $DF/PF + = DF_{ref} - DF_{meas}$

as described in 3.3 on page 29.

A re-calibration of the *CP TD1* is also shown in the test report (.xml file).

Note: If you change the factory-made calibration, the responsibility for the accuracy of the *CP TD1* will be in your hands.

2.4.1 Calibration Tips

- For calibration set the averaging factor to maximum and the filter bandwidth to $\pm 5\text{Hz}$ (refer to 3.1 "TanDelta Test Card - Main Page (1/2)" on page 25).
- To reset to the factory settings, select "DF/PF+" to 0.0 ppm and "Cx" to 1.000 (refer to 3.3 "TanDelta Test Card - Settings Page (1/2)" on page 29).

3 Test Cards

3.1 TanDelta Test Card - Main Page (1/2)

The test card **TanDelta** can be accessed from CT, VT, TRANSFORMER and OTHERS.

Select "Assessment" to automatically assess the test, clear for no assessment.

Enter the nominal values in the entry fields (here "Cref" and "DFref"; availability and naming depend on the measuring mode). These values serve as reference for the assessment. Their tolerance range can be set on the **Settings** Page (refer to page 29).

A measurement is rated as 'OK' if **both** values are within their tolerance range. The assessment is displayed in the test point tables's column "?"

Note: While a test is running, new nominal values can already be entered.

Test voltage and frequency.

Select for automatic measurement, clear for manual measurement.*).

Selecting enables the list boxes.

Selecting a measuring mode and pressing the handwheel displays an image that shows the according arrangement of the internal measurement switch-matrix.**)

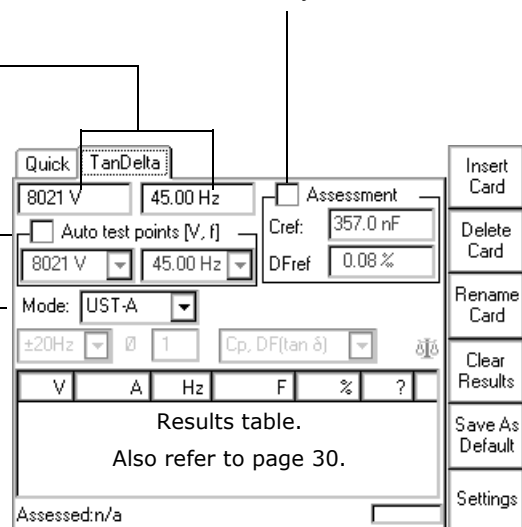

*) **"Auto test points" cleared = manual measurement:** Applies the set test voltage and frequency to the *CP TD1*'s output. When the measurement is finished, its results are displayed in the results table.

"Auto test points" selected = automatic measurement: Enables the output of a series of test points, e.g., combining a series of voltage values with one fixed frequency value creates a voltage ramp. Combining a series of frequency values with one fixed voltage value creates a frequency ramp. Furthermore, a combination of both is possible.

- Set a test voltage and frequency of your choice, and press **ADD TO AUTO**. The values are entered into the list boxes.
- Set a second test voltage and/or frequency, and again press **ADD TO AUTO**. The value(s) is/are appended to the list.
- Repeat this procedure as often as you need.

Note: You cannot enter the same value twice. Double entries are rejected. If you need identical test points for an increasing and a decreasing voltage ramp, set values very close to each other, e.g., 2000V and 2001V.

The *CP TD1* then puts out the specified list of values as follows:

1. All voltages are issued in the exact order they were entered using the **first** frequency value of the list.
2. All voltages are issued once more in the exact order they were entered using the **second** frequency value of the list (if any).
3. ... and so forth.

Each combination is one individual measurement, and its result is displayed in the results table with an individual line.

To delete an entry from a list box, place the cursor on the value and press **DELETE VALUE**. To delete all values from both list boxes, place the cursor on "Auto test points (V, f)" and press **DELETE LIST**.

During the measurement, the list boxes display the current output values.

***) **Measuring modes and their according arrangements of the internal switch-matrix in the CP TD1.**

The switch-matrix determines what capacities are actually measured.

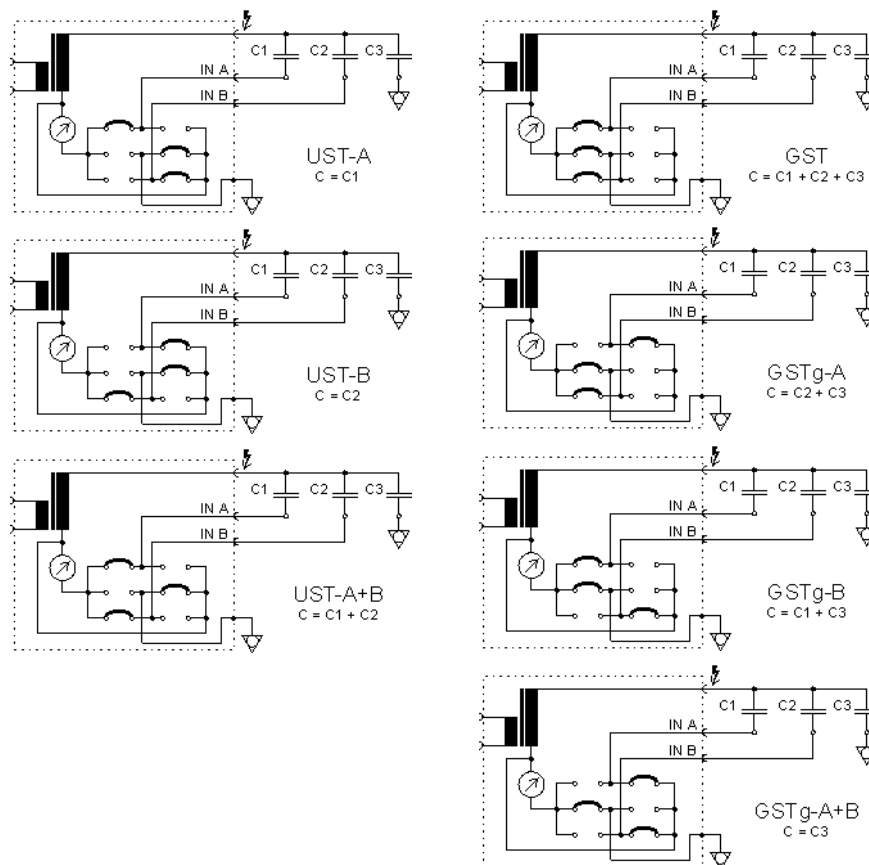

3.2 TanDelta Test Card - Main Page (2/2)

Compound measurement setting.

- Cp, DF (tan δ) = parallel capacitance & dissipation factor
- Cp, PF (cos ϕ) = parallel capacitance & power factor
- Cp, Ptest = parallel capacitance & power
- Cp, P@10kV = parallel capacitance & power
linearly interpolated to 10 kV test voltage
- Qtest, Stest = reactive & apparent power
- Z = impedance with phase angle
- Cp, Rp = parallel capacitance & parallel resistance
- Ls, Rs = serial inductance & serial resistance
- Cp, Q = parallel capacitance & quality factor
- Ls, Q = series inductance & quality factor

The averaging factor determines the number of measurements. A factor of 3 means: the CP TD1 carries out 3 measurements whose results are then averaged. The higher the factor, the more accurate the measurement but the longer the measuring time.

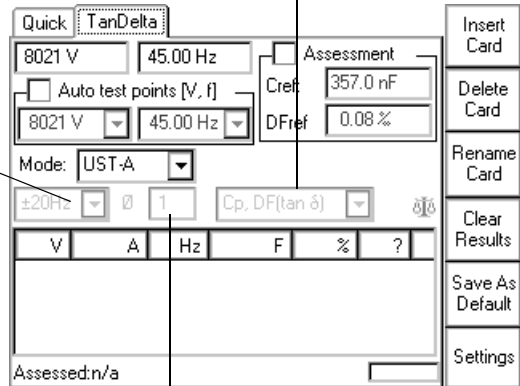

Filter bandwidth of measurement.

Note: If the test frequency equals the default frequency (as set at OPTIONS | DEVICE SETUP), the filter bandwidth is always ± 5 Hz, regardless of the set value. This even applies if the option "use default frequency of xx.xx Hz" is not specifically selected.

± 5 Hz means that interferences at frequencies with an offset of $\geq \pm 5$ Hz from the measuring frequency will not affect the results.

The smaller the filter bandwidth, the longer the measuring time.

3.3 TanDelta Test Card - Settings Page (1/2)

The TanDelta **Settings** page allows for the setting of additional measurement options. To open it, press the **SETTINGS** button on the **TanDelta** Main Page.

The *CP TD1* leaves OMICRON factory-calibrated. If a component needs to be exchanged by a spare part, the *CP TD1* must be re-calibrated.

To re-calibrate, set the focus onto the test card tab designation **TanDelta** and press **EDIT CALIB** to enable the entry fields:

- Cx = correction factor for Cmeas (multiplier)
- DF/PF + = corrective value added to dissipation or power factor (can be + or -).

Note: You must enter your name and press **UPDATE CALIB.** to complete the re-calibration.

If selected, the beeper sounds during the entire test to signal the output of hazardous high voltages. If cleared, the beeper sounds at the beginning and the end of the test only.

If selected, the *CPC 100* checks whether the shield of the high-voltage cable is connected. For some large inductive loads, the *CPC 100* can accidentally report shield check error even when the shield is connected. If this is the case, it makes sense to clear the check box.

At "Assessment Limits", set the tolerance of the Main Page's nominal values for the assessment.

For the capacitance, the tolerance is entered in percent, for the dissipation factor it's a multiplier.

Note: Availability and naming of the entry fields depend on the measuring mode, e.g., DF and PF are the same entry field.

The screenshot shows the TanDelta Settings page with the following fields and options:

- Assessment Limits:**
 - ±dC: 0.1 %
 - DFref x: 2.0
- Custom Calibration:**
 - Cx: 1.027
 - DF/PF +: 0.0 ppm
 - by: John Doe
 - V13.8 10/2/03
- Compensations:**
 - Compensations
 - kx: 1.16
 - T oil: 31.4 °C
 - T amb.: 16.2 °C
 - rel.Hum.: 46.0 %
 - Use ext. CT
 - Ratio: 3.0
- Checkboxes:**
 - Use Beeper
 - Perform shield check
- Other:**
 - Set temperature correction factor. (118)
 - ANSI C57.12
 - Bushings
 - Main Page



Warning: Never operate the *CP TD1* with unconnected shield of the high-voltage cable. If the "Perform shield check" check box is cleared, make sure that the shield is connected before operating the *CP TD1*.

3.4 TanDelta Test Card - Settings Page (2/2)

Selecting "Compensations" converts the actually measured dissipation or power factor to normalized values corresponding to an ambient temperature of 20° C. In doing so, the values entered at "Compensations" represent the existing ambient condition.

- Enter oil temperature, ambient temperature (at bushing) and relative humidity first.
- Then place the cursor on "k".

The medium the measurement takes place in, oil or air, determines the k-factor.

- ANSI C57.12

The oil temperature is the determining medium for the k-factor.

- Bushings

The air temperature at the respective bushing is the determining medium for the k-factor. BUSHINGS provides three bushing types to select from: RBP (**R**esin **B**onded **P**aper), RIP (**R**esin **I**mpregnated **P**aper) and OIP (**O**il **I**mpregnated **P**aper). The k-factor changes accordingly.

The screenshot shows the 'TanDelta' settings page with the following fields and options:

- Assessment Limits:** ±dC: 0.1 %, DFref x: 2.0
- Custom Calibration:** Cx: 1.027, DF/PF +: 0.0 ppm, by: John Doe, V13.8, 10/2/03
- Compensations:** Compensations, kx: 1.16, T oil: 31.4 °C, T amb.: 16.2 °C, rel.Hum.: 46.0 %
- Use ext. CT:** Use ext. CT, Ratio: 3.0
- Other options:** Use Beeper, Perform shield check
- Footer:** Set temperature correction factor. (118) and an information icon.

Select if you use an external CT.

The entered ratio is used to calculate the measured current accordingly.

Note: "Use ext. CT" can only be selected if there are no measurement results yet.

Returns to TanDelta's Main Page

3.5 Templates

The test procedures for designated applications are controlled by templates available on the *CPC Toolsets* shipped with your *CP TD1* or on the *CPC 100 Start Page*.

The templates are pairs of XML documents and Microsoft Excel templates designed by OMICRON electronics for designated applications. The XML templates are predefined test procedures, often with comments, that run on the *CPC 100* and guide you through the test. Once completed, the XML file is saved, downloaded to the PC and then loaded into the corresponding Microsoft Excel template. There the results are post-processed and a final test report is generated. The template pairs facilitate and speed testing with the *CP TD1* and the evaluation of results.

To perform a test using a template, open the template for your application and run the test procedure according to the template.

4 Application

4.1 Preparations in Substation



Warning: Prior to connecting a test object to the *CP TD1*, the following steps need to be carried out by an authorized employee of the utility.

- Turn off and disconnect the high voltage from the test object.
- Protect yourself and your working environment against an accidental re-connection of high voltage by other persons and circumstances.
- Verify a safe isolation of the test object.



Warning: Earth-connect and shorten out the test object's terminals using a grounding set.

- Protect yourself and your working environment with a suitable protection against other (possibly live) circuits.
- Protect others from accessing the dangerous area and accidentally touching live parts by setting up a suitable barrier and, if applicable, warning lights.
- If there is a longer distance between the location of the *CP TD1* and the area of danger (that is, the test object), a second person with an additional "Emergency Stop" button is required.

4.2 Connection



Warning: Make sure to position the test object or *CP CAL* in the high-voltage area.



Warning: Never use the *CP TD1* without a solid connection to ground with at least 6 mm². Use a ground point as close as possible to the test object.



1. **Without trolley:**
Properly connect the *CPC 100* and *CP TD1* grounding terminals to substation ground.

With trolley (optional):

Properly connect the *CPC 100* and *CP TD1* grounding terminals to the trolley's ground bar. Connect the ground bar to earth.

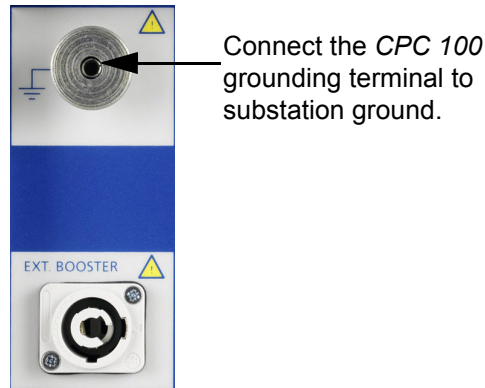

2. Switch off the *CPC 100* at the mains power switch.
3. Connect the *CP TD1*'s "BOOSTER IN" to the *CPC 100*'s "EXT. BOOSTER" with the booster cable.
4. Connect the *CP TD1*'s "SERIAL" to *CPC 100*'s "SERIAL" with the data cable. This cable also provides the power supply for the *CP TD1*.
5. Make sure that all cable connectors are clean and dry before being tightly connected.
6. Pull out the measuring cables from the cable drum and connect the test object to the *CP TD1*'s measuring inputs IN A and IN B.
7. Connect the high-voltage cable from the test object to the *CP TD1*'s high-voltage output.
 - At the *CP TD1*, press the high-voltage cable's plug to the connector tightly and turn the screw cap manually without using any tools until you feel a mechanical stop. If you notice a rough-running of the screw-cap, clean the screw thread and use a lubricant (vaseline recommended).
 - Insert the yellow banana plug (the high-voltage cable's grounding) into the respective plug socket.
 - At the test object, insert the high-voltage cable's plug carefully until you feel a "click" position. Now they are locked. Confirm this by trying to pull them out. This should not be possible now.
 - The high-voltage cable is double-shielded and therefore safe. However, the last 50 cm (20 inch) of this cable have no shield. Therefore, during a test consider this cable a life wire and due to the high-voltage life-hazardous!
8. Connect the *CPC 100* to the mains power supply using the provided cable.

9. Remove the grounding set from the test object.



Warning: Establish a barrier to the high-voltage area.

10. Turn on the *CPC 100* at its mains power switch at the left-hand side.
11. An error message (313) appears if there is no ground connection, neither via PE (protective earth wire of the power supply) nor via grounding terminal or the power supply has no galvanic connection to ground. The latter is the case on very special power supplies like with diesel generators or when insulation transformers are used.



Warning: This is a safety-relevant message. If the reason for this message is that neither PE nor grounding terminal is connected, it can cause injury or possibly death of the operating staff. For safe operation always make sure that both PE and grounding terminal are connected.

12. If the PE and grounding terminal connection are intact and the error message still appears, select the "Disable ground check" check box at the **Device Setup** tab in the **Options** view.

Note: After the *CPC 100* has been rebooted, the "Disable ground check" check box is cleared for safety reasons.



13. The green warning light "O" lights up, showing that the *CPC 100* output does not carry a dangerous voltage or current yet.

Note: If none or both warning lights are on, the unit is defective and must not be used anymore.

4.3 Measurement

1. Set up your test in the *CPC 100* software.
For a detailed description of how to use the software refer to respective section in the *CPC 100* Reference Manual.
2. Selecting the **TanDelta - PF** test card from the *CPC 100*'s menu automatically turns on the *CP TD1*. If no *CP TD1* is connected to the *CPC 100*, an error message occurs.
3. Set up your measurement in the **TanDelta - PF** test card (see 3.1 on page 25).

- Once all test cards are prepared and the parameters set, make sure the safety key lock is in position "release" (horizontal).



Warning: If you have a cardiac pacemaker, do not use the *CP TD1*! Before operating the *CP TD1*, make sure there is no person with a cardiac pacemaker in the immediate vicinity.



Warning: Never touch any metallic terminals and / housing components without a visible ground connection!



- Start the test by pressing the green I/O (test start/stop) push-button on the *CPC 100* front panel.

Note:

- A test can only be started in the Test Card View and with all preconditions met (refer to the *CPC 100* Reference Manual).
- If voltages ≥ 1 kV are to be applied, after pressing the I/O (test start/stop) push-button for the first time a warning message appears on the screen.

Only after the I/O push-button is pressed a second time, the voltage is applied to the *CPC 100* output.

Rather than starting a test and activating the outputs, pressing the I/O (test start/stop) push-button will then pop up a message box notifying you about this problem.



- If a potentially hazardous voltage and/or current level is applied to the *CPC 100* outputs, the red signal red light "I" starts flashing.

4.4 Disconnection

- Switch off the high voltage with the I/O (test start/stop) push-button.

Note: Even if you switched off the *CPC 100*, wait until the red I/O warning light is fully extinguished. As long as this warning light is lit, there is still voltage potential on the output. The green warning light indicates that the *CPC 100* outputs are not activated.

- Press the **Emergency Stop** button on the *CPC 100* front panel.

3. Turn the safety key to "lock" (vertical) and remove the key to avoid anybody accidentally turning on the high voltage.



Warning: Earth-connect and shorten out the test object's terminals using a grounding set.

4. Plug off the high-voltage cable from the high-voltage output of the *CP TD1*.
5. Disconnect the cables from the *CP TD1*.

5 Capacitance and Dissipation Factor Measurement

Capacitance (C) and Dissipation Factor (DF) measurement is an established and important insulation diagnosis method. It can detect:

- Insulation failures
- Aging of insulation
- Contamination of insulation liquids with particles
- Water in solid and liquid insulation
- Partial discharges

5.1 Theory

In an ideal capacitor without any dielectric losses, the insulation current is exactly 90° leading according to the applied voltage. For a real insulation with dielectric losses this angle is less than 90° . The angle $\delta = 90^\circ - \varphi$ is called loss angle. In a simplified diagram of the insulation, C_p represents the loss-free

capacitance and R_p the losses (Figure 5-1). Losses can also be represented by serial equivalent circuit diagram with C_s and R_s (chapter 12.1). The definition of the dissipation factor and the vector diagram are shown in Figure 5-2.

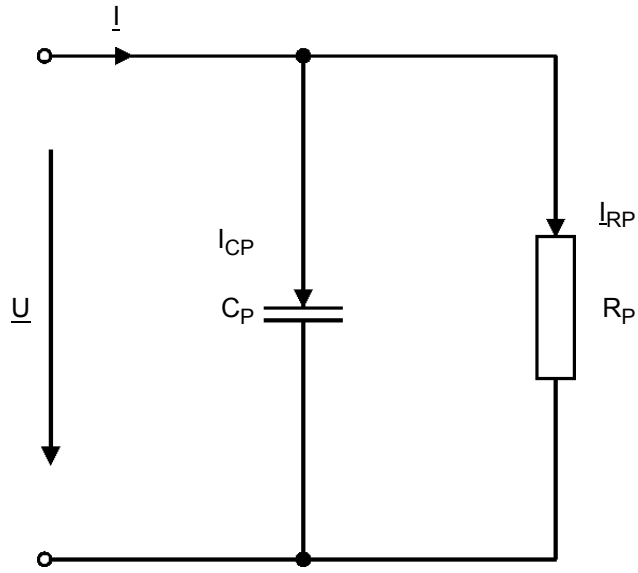

Figure 5-1 Simplified circuit diagram of a capacitor

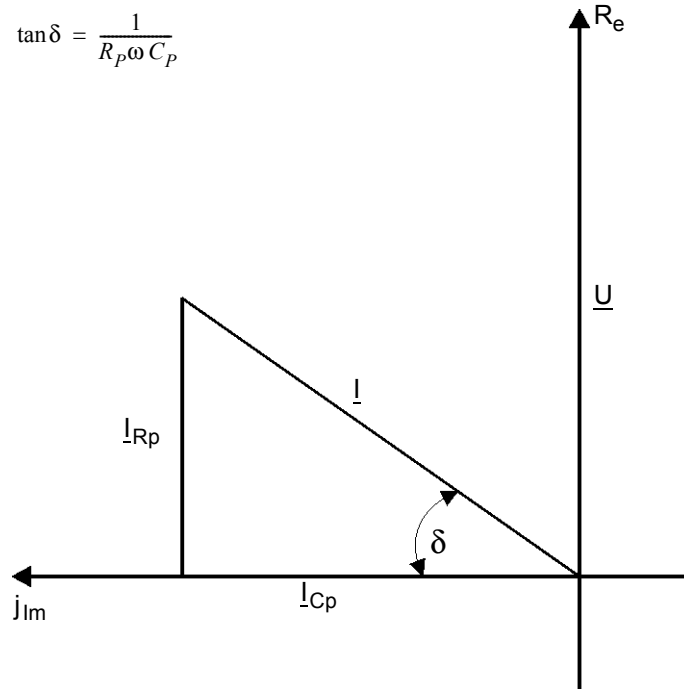
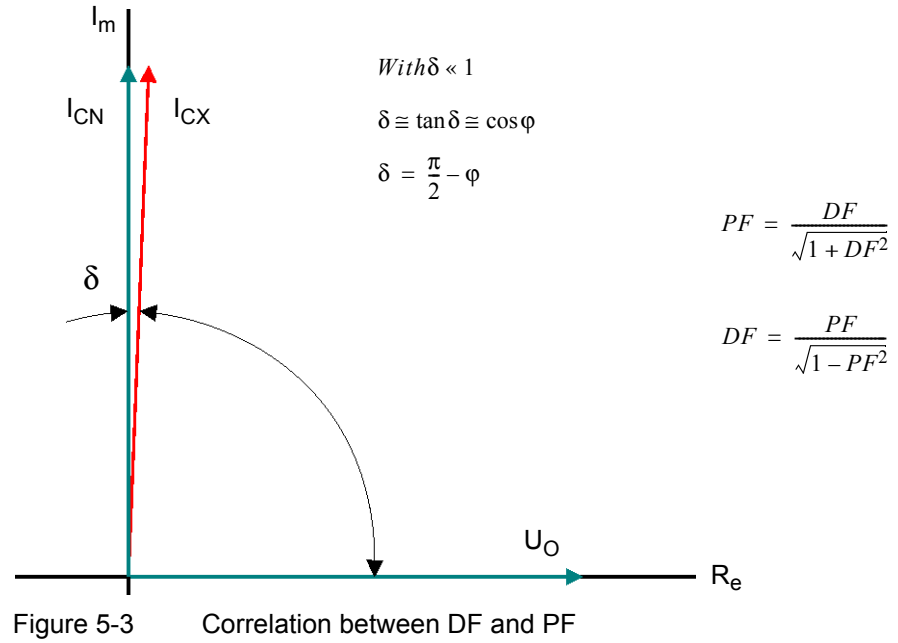

Figure 5-2 Definition of dissipation factor ($\tan \delta$) and the vector diagram

The correlation between the Dissipation Factor and Power Factor (PF = cos φ) and the vector diagram are shown in Figure 5-3.



The dielectric losses in the insulation are caused by:

- movement of conductive particles
- movement of ions and electrons
- polarization effects (Figure 5-4)

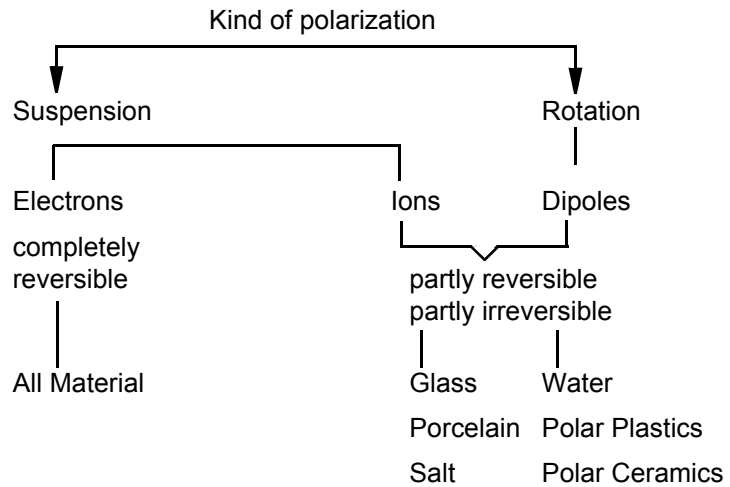

Figure 5-4 Kind of polarization

Polarization losses are generated due to suspension and rotation effects. Suspension of electrons is completely reversible. Figure 5-5 shows this mechanism. This kind of polarization is also called "Atom Polarization".

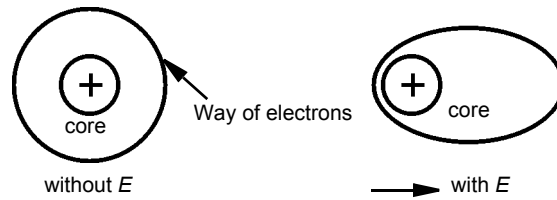

Figure 5-5 Polarization of electrons in the electrical field

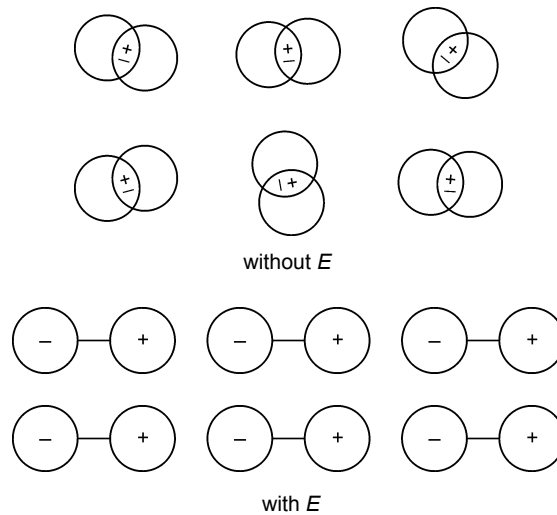

Figure 5-6 Polarization of ions in the electrical field

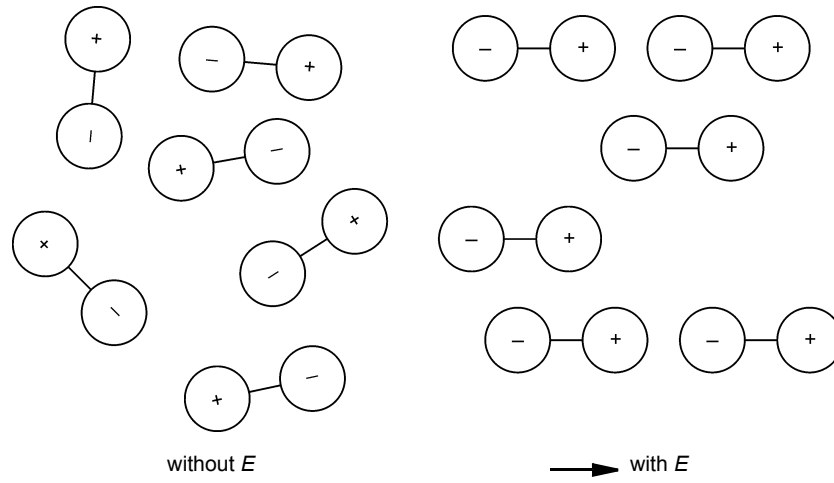

Figure 5-7 Polarization of dipoles in the electrical field

A typical dipole is a water molecule. Figure 5-8 shows such a molecule in the electrical field. When the electrical field changes the polarity, the orientation of the water molecule is changed by 180° . This rotation, along with the applied frequency, causes the described losses.

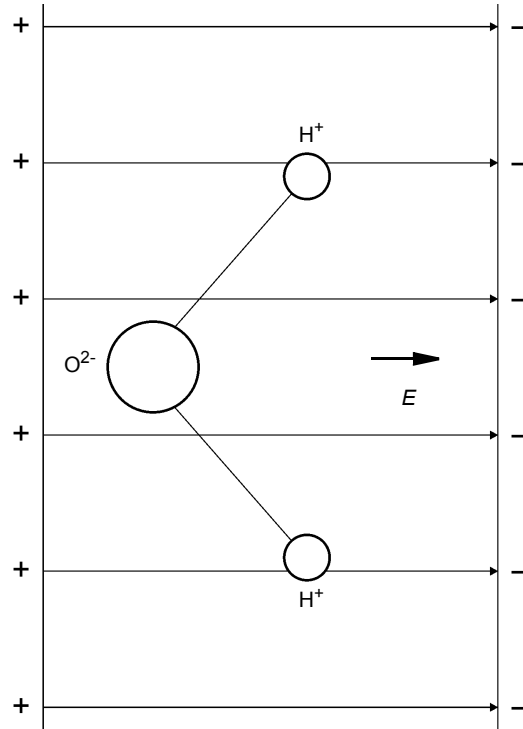

Figure 5-8 Water molecule in the electrical field

Additional losses are known as interfacial polarization. Inter-phase boundaries (e.g., between solid and liquid insulation material) may be charged, i.e., the electrical field moves the charge carriers in the oil; the charge carriers come to rest upon the boundary to the solid insulation material and create a space

charge region. These space charge regions are moved back and forth through the field. This effect, for example, occurs on the interface between transformer oil and solid insulation like paper or transformer board (Figure 5-9).

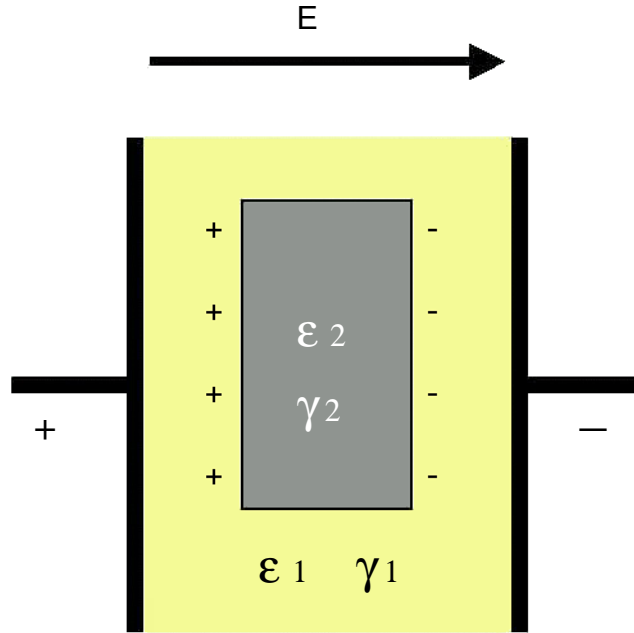

Figure 5-9 Interfacial polarization

Influence of different parameters like water content, temperature and aging on DF

Figure 5-10 shows the breakdown voltage and the DF in oil, dependent on the water content [2.3]. With low water content, the breakdown voltage is very sensitive; with higher water content, the DF is a good indicator.

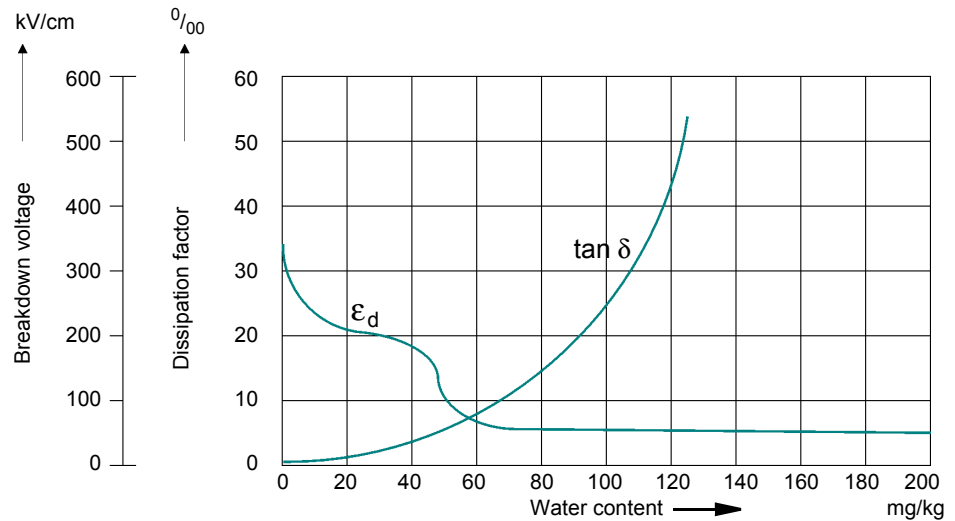

Figure 5-10 Breakdown voltage and DF in oil, dependent on the water content

Figure 5-11 shows the DF of new and used oil, dependent on the temperature. With higher temperatures, the viscosity of the oil decreases so the particles, ions and electrons can move easier and faster. Thus the DF increases with temperature [2.3].

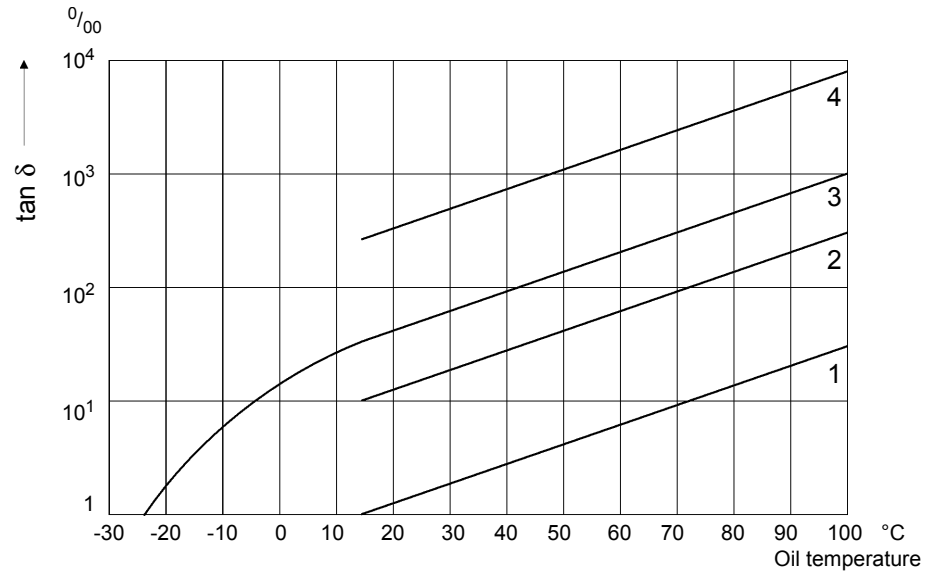

Figure 5-11 DF of new and aged oil, dependent on temperature

Dissipation Factor: Dependency of the temperature

1 = new oil

2, 3 and 4 = used oil

Figure 5-12 and table 5-1 show a temperature correction factor (according to ANSI 57.12.90) for insulation based on mineral oil [2.4].

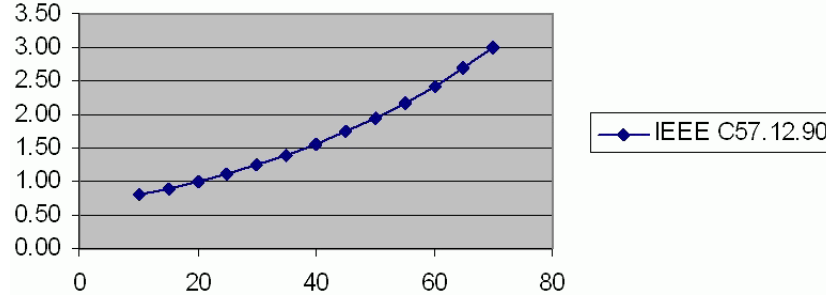

Figure 5-12 Temperature correction factor for mineral oil insulation [2.4]

$$F_{p20} = \frac{F_{pt}}{K}$$

where

F_{p20} is the power factor corrected to 20°C

F_{pt} is the power factor measured at T

T is the test temperature (°C)

K is the correction factor

Table 5-1 Temperature correction factor for mineral oil insulation [2.4]

Test temperature T (°C)	Correction Factor K
10	0.80
15	0.90
20	1.00
25	1.12
30	1.25
35	1.40
40	1.55
45	1.75
50	1.95

Table 5-1 Temperature correction factor for mineral oil insulation [2.4]

Test temperature T (°C)	Correction Factor K
55	2.18
60	2.42
65	2.70
70	3.00

Note: The correction factors listed above base on insulated systems using mineral oil as an insulating liquid. Other insulating liquids may have different correction factors.

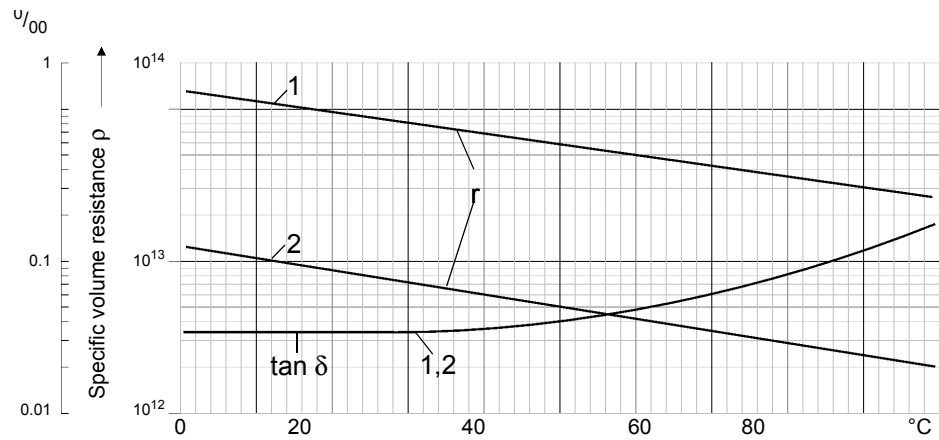

Figure 5-13 Temperature behavior of silicon liquid [2.3]

Dissipation Factor - Dependency of the temperature

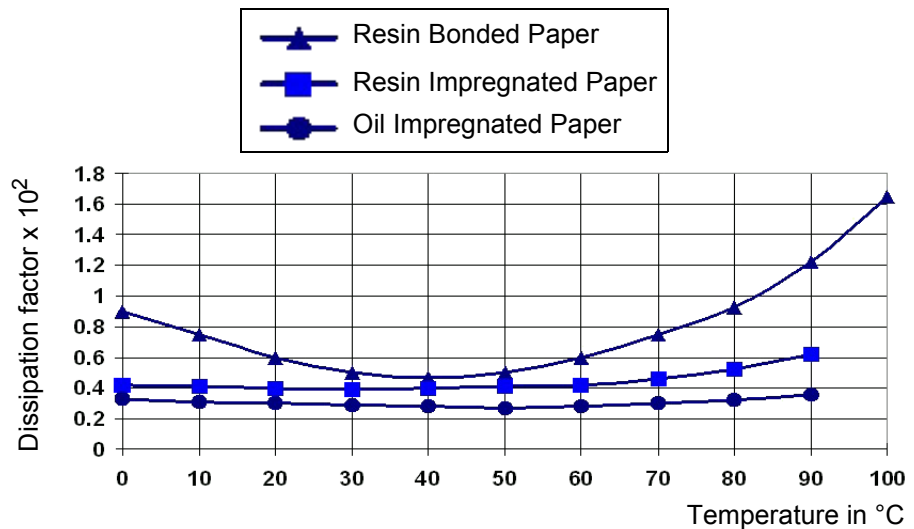

Figure 5-14 Temperature behavior RBP, RIP, and OIP bushing [2.5]

The dissipation factor is dependent on the frequency. With modern test devices like the *CPC 100 + CP TD1*, it is possible to cover a wide frequency range for capacitance and DF measurements. Up to now, fingerprint measurements for comparison are normally available only at line frequency. The following figures show the frequency dependency for transformer windings (oil-paper insulation) and an OIP bushing (Figures 5-15 and 5-16).

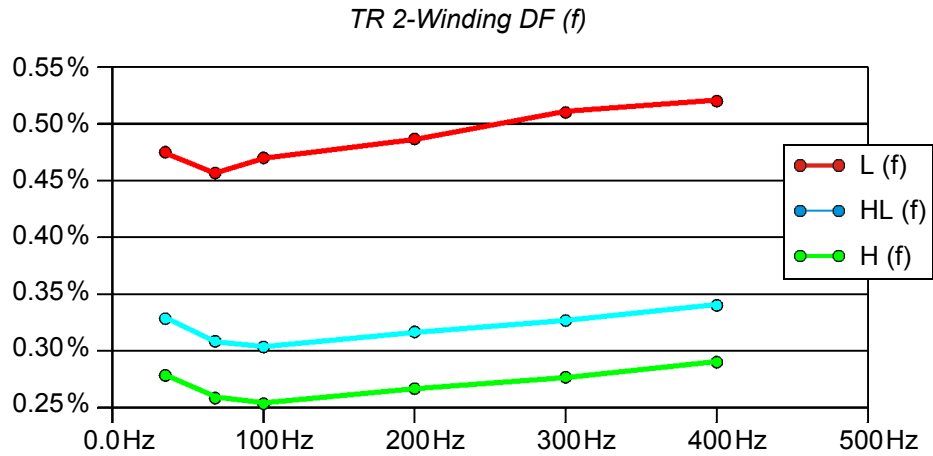

Figure 5-15 Frequency scan winding to winding DF measurement (oil-paper)

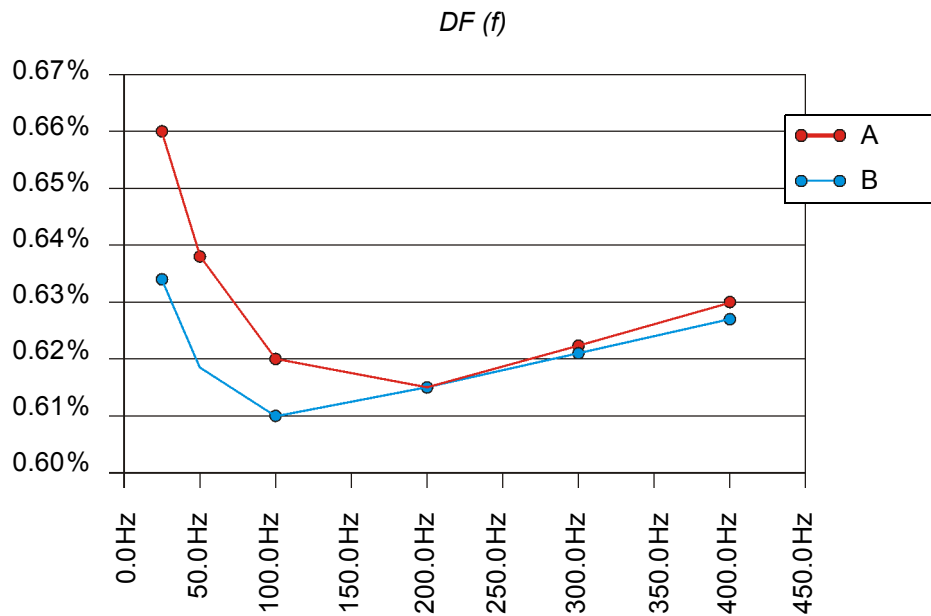

Figure 5-16 Frequency scan of a OIP bushing (Phase A and B)

The dissipation factor is in many cases also dependent on the test voltage. Figure 5-17 shows a measurement of a 6kV motor. Above 4kV, partial discharges occur. This is the reason for the rise of DF.

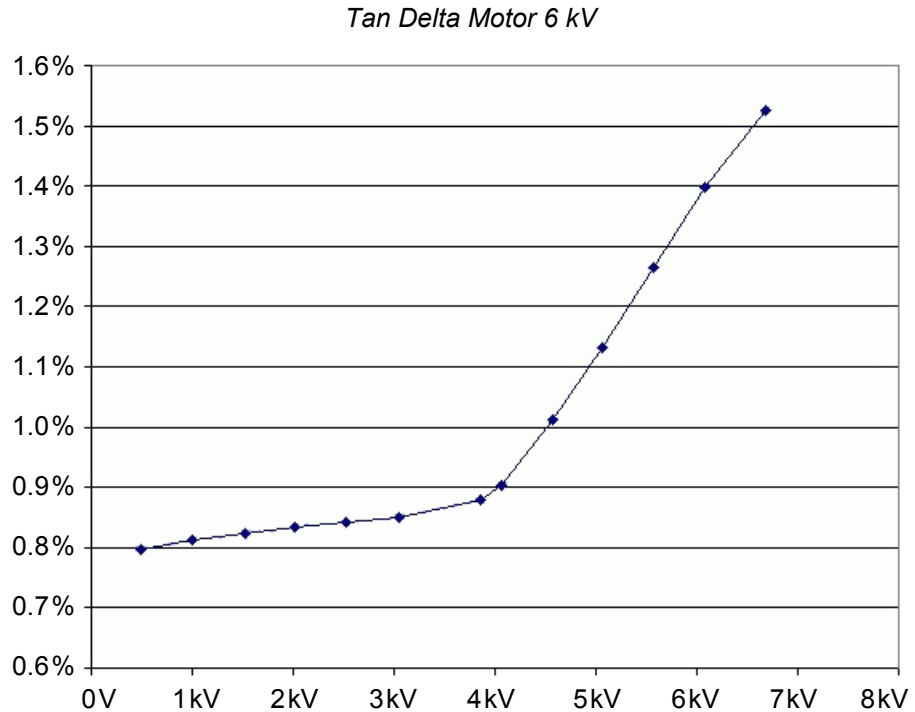

Figure 5-17 Voltage scan of a 6 kV motor

5.2 Measurement of Capacitance and Dissipation Factor / Power Factor

Capacitance (C) and Dissipation Factor (DF) measurement was first published by Schering in 1919 [2.1] and utilized for this purpose in 1924 (Figure 5-18). The serial connected C_1 and R_1 represent the test object with losses, C_2 the loss-

free reference capacitor. The parallel circuit diagram shown in Figure 5-1 can be transferred as a direct equivalent into this serial diagram at specified frequencies (section 12.1).

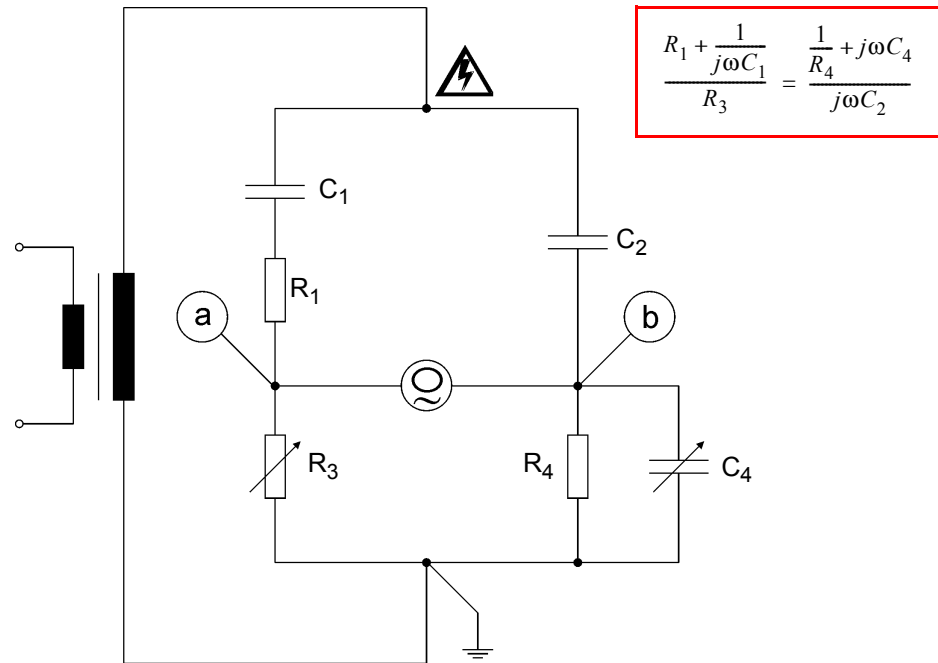

Figure 5-18 Schering bridge

Real parts: $\frac{R_1}{R_3} = \frac{C_4}{C_2} \Rightarrow R_1 = \frac{C_4}{C_2} \times R_3$

Imaginary parts: $C_1 \times R_3 = C_2 \times R_4 \Rightarrow C_1 = \frac{R_4}{R_3} \times C_2$

$\tan \delta = R_1 \times \omega C_1$

$\tan \delta = C_4 \times \frac{R_3}{C_2} \times \omega \times \frac{R_4}{R_3} \times C_2$

$\tan \delta = \omega \times C_4 \times R_4$

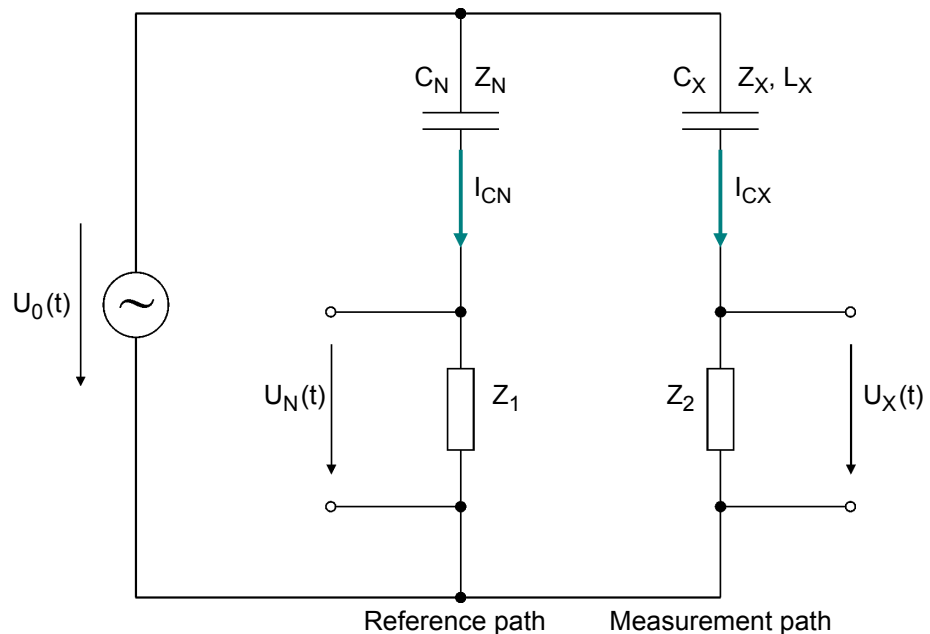

Figure 5-19 CP TD1 measuring principle

The *CP TD1* test system utilizes a method similar to that of the Schering bridge. The main difference is that the *CP TD1* measuring principle (Figure 5-19) does not require tuning for measuring C and DF . C_n is a gas insulated reference capacitor with losses below $10E-5$. For laboratory use, such capacitors are regularly used to obtain precise measurements, as the ambient lab temperature normally ranges between $20 - 25\text{ }^\circ\text{C}$ ($68 - 77\text{ }^\circ\text{F}$). When carrying out on-site measurements, however, temperatures can vary significantly, which results in changes of the electrodes geometry.

The *CP TD1* takes all these effects into account and compensates for them electronically, so it is now possible for the first time to measure in the field down to $DF = 5 \times 10E-5$. Figure 5-20 shows the complete equivalent circuit diagram.

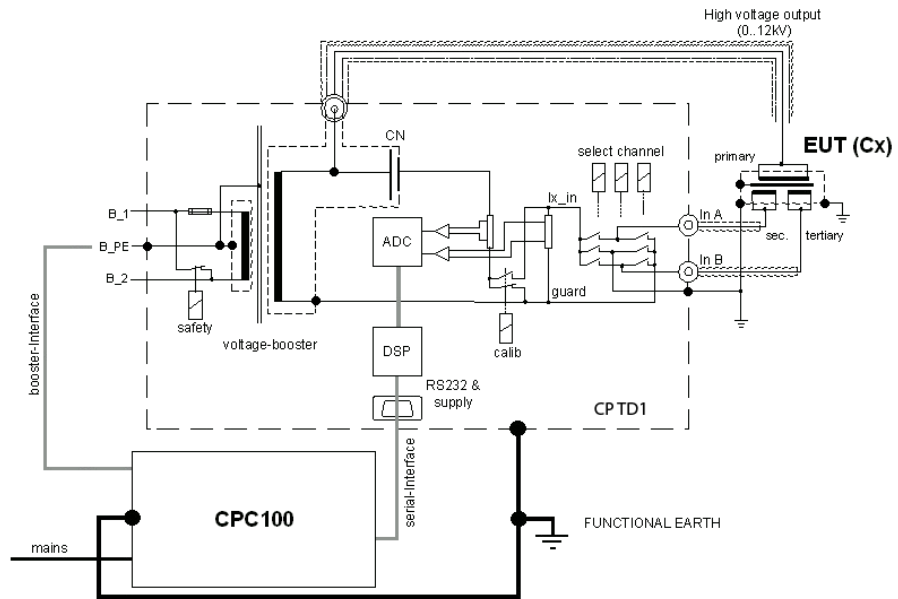

Figure 5-20 *CP TD1* measuring principle

To the present day, the dissipation or dissipation factor was measured only at line frequency. With the power source described in [2.2], it is now possible to make these insulation measurements in a wide frequency range. Beside the possibility to apply frequency scans, measurements can be made at frequencies different from the line frequency and their harmonics. With this principle, measurements are possible also in the presence of high electromagnetic interference in high-voltage substations.

5.3 "UST" and "GST" Measurements Using the Guard Technology

In electrical devices like power transformers there are a lot of insulation gaps, which have to be checked separately:

- Winding to winding
- Winding to tank & core
- Bushings

A three-winding transformer with the different insulation gaps is shown in figure 5-21. Only one phase is drawn. With a three-phase transformer the equivalent circuit diagram is very similar, because normally the phases of the high-voltage (H), the low-voltage (L) and the tertiary (T) windings are connected internally in y or delta. This way only the sum of all three phases can be measured, the single phases can not be measured separately.

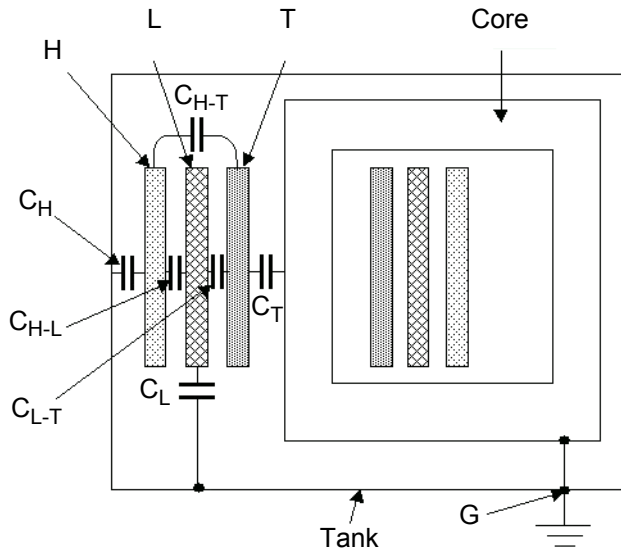

Figure 5-21 Three-phase transformer with winding capacitances

H	High-Voltage winding	C H	Cap. H to Ground	C H-L	Cap. H to L
L	Low-Voltage winding	C L	Cap. L to Ground	C L-T	Cap. L to T

T	Tertiary winding	C T	Cap. T to Ground	C H-T	Cap. H to T
---	------------------	-----	------------------	-------	-------------

For the separate measurement of all capacitors a so-called guard technique is necessary. The single capacitors connected to guard are energized but not measured.

In Figure 5-22 a block diagram of the *CP TD1* is shown with the guard connection and measuring input. In the example case C_1 , C_2 and C_3 are capacitors, connected to the *CP TD1*. C_1 is connected to input A, C_2 is connected to input B and C_3 is connected to ground. All three capacitors are energized. Only C_1 is measured, because the relay matrix only connects C_1 to the measuring input (instrument), whereas the currents through C_2 and C_3 are bypassed. C_2 and C_3 are connected to the foot-point of the HV transformer (GUARD).

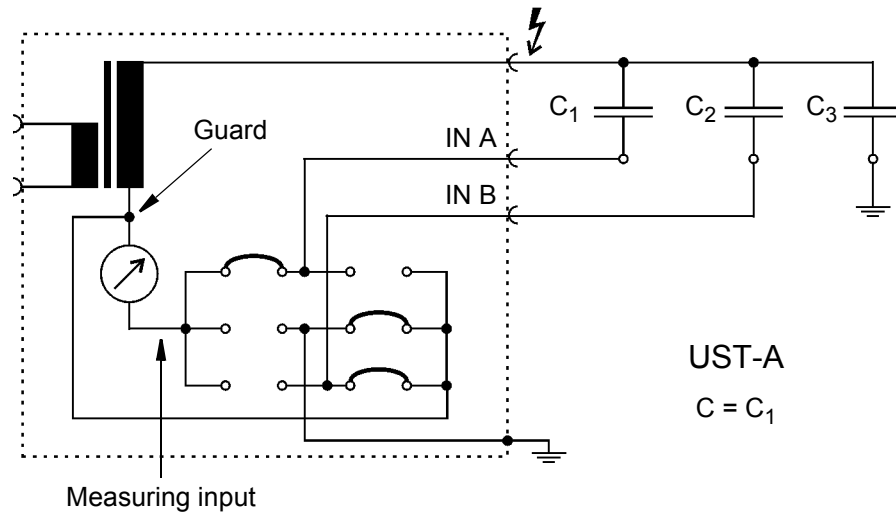

Figure 5-22 *CP TD1* block diagram with GUARD and measuring input

To get more familiar with this technique we want to measure C HL, C HT and C H of Figure 5-21. The high-voltage winding is connected to the test voltage (high-voltage output of the *CP TD1*), the low-voltage winding is connected to IN A and the tertiary winding is connected to IN B.

If big capacitance values are expected, we should start with a GST measurement first. In the GST mode all connected capacitors are measured in parallel ($C_{HL} + C_{HT} + C_H$). This way we can check if the *CP TD1* is overloaded during the measurements or not (Figure 5-23) and we can check the single measurements. The capacitance value out of this measurement must be the sum of the following single measurements.

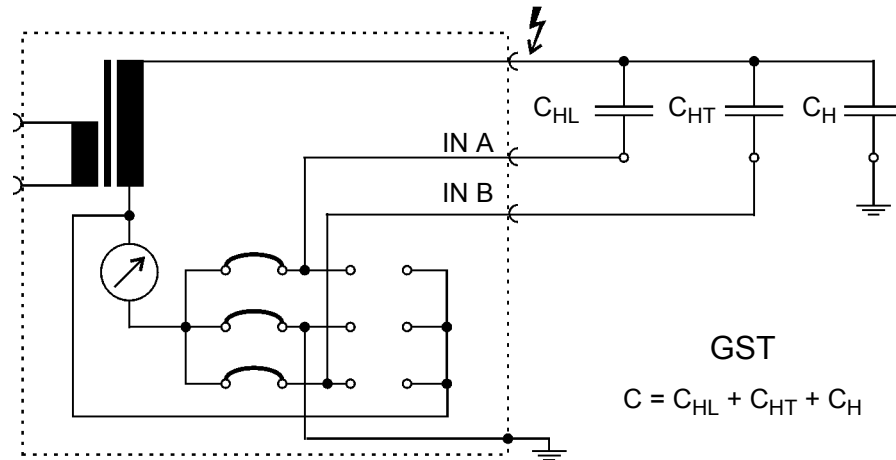

Figure 5-23 *CP TD1* block diagram of GST mode

Now we want to measure C_{HL} . The connection diagram is shown in Figure 5-24. The measuring mode is UST-A.

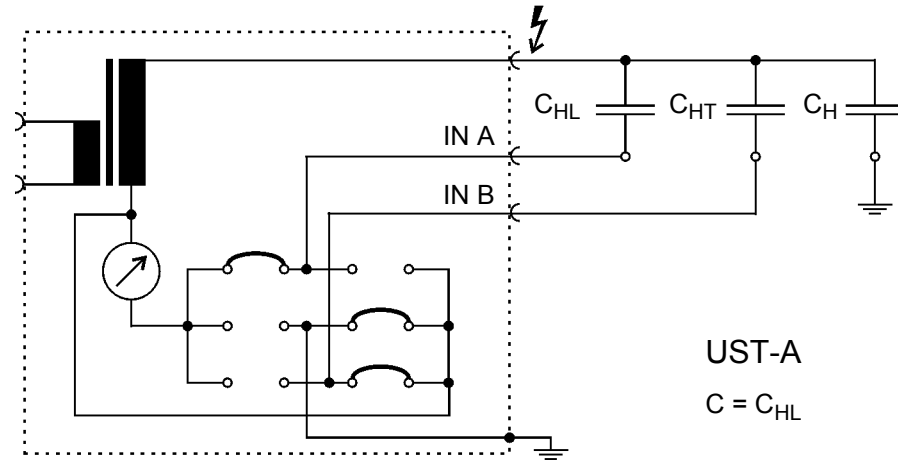

Figure 5-24 Measurement of C_{HL} in UST-A mode, C_{HT} and C_H are guarded

Next measurement is C HT. The connection diagram is shown in Figure 5-25. The measuring mode is UST B. Without the GUARD technique it would not be possible to measure C HT separately, because C HL in series to C LT are in parallel to C HT. Only by connecting L to GUARD the current flowing to L is not measured.

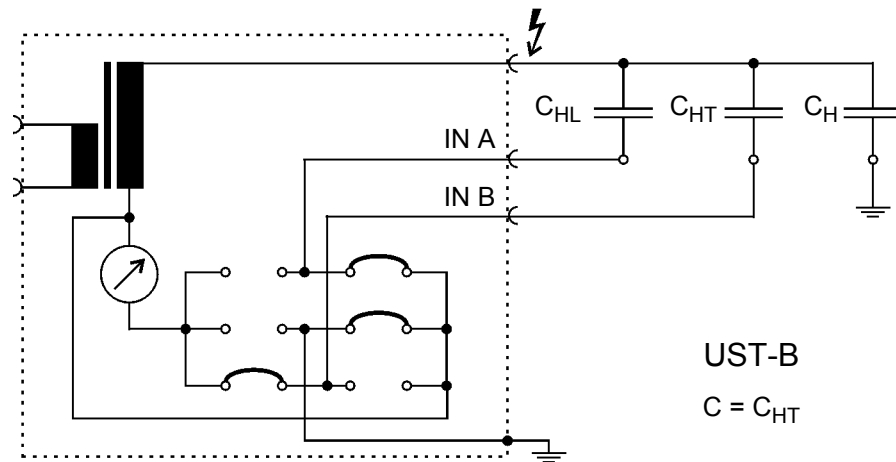

Figure 5-25 Measurement of C HT in UST-B mode, C HL and C H are guarded

The last measurement is C_H . Figure 5-26 shows this connection diagram. The measuring mode is GSTg-A+B. C_{HL} and C_{HT} are not measured, because they are connected to GUARD.

The build-in relay matrix enables the described four different measurements without any rewiring. This principle can be used not only for transformers, but also for any system with partial capacitors inside.

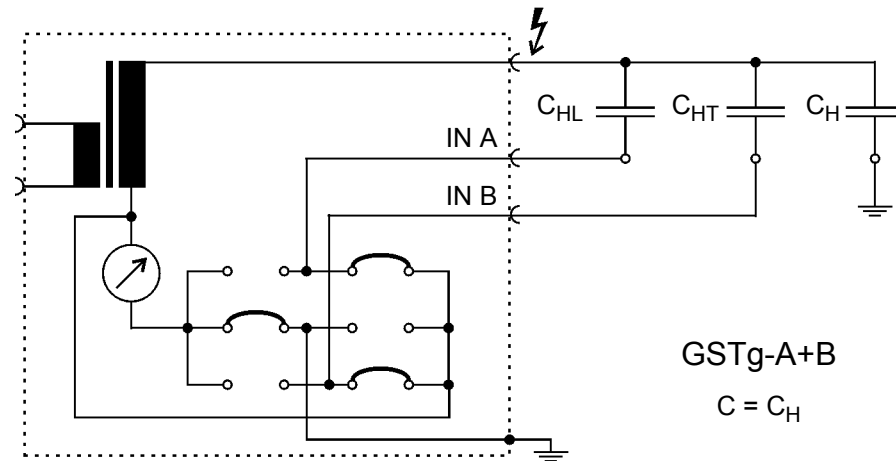

Figure 5-26 Measurement of C_H in GST-gA+B mode, C_{HL} and C_{HT} are guarded

5.4 References

- [2.1] Schering, H.: "Brücke für Verlustmessungen", Tätigkeitsbericht der Physikalisch-Technischen Reichsanstalt, Braunschweig 1919
- [2.2] Hensler, Th., Kaufmann, R., Klapper, U., Krüger, M., Schreiner, S.: "Portable testing device", US Patent 6608493, 2003
- [2.3] Krüger, M.: "Prüfung der dielektrischen Eigenschaften von Isolierflüssigkeiten", ÖZE, No. 5, Vienna, May 1986
- [2.4] "IEEE Standard Test Code for Liquid-Immersed Distribution, Power, and Regulating Transformers", IEEE Std C57.12.90-1999

- [2.5] Seitz, V.: "Vorbeugende Instandhaltung an Leistungstransformatoren – Betriebsbegleitende Messungen an Stufenschaltern und Durchführungen, OMICRON Anwendertagung 2003, Friedrichshafen

6 Power Transformers

6.1 Introduction



Due to ever-increasing pressure to reduce costs, the power industry is forced to keep old power facilities in operation as long as possible. In most European countries, about one third of the transformers are over 30 years old. Even transformers older than 50 years are still in service. A regular check of the operating conditions becomes more and more important with the advancing age of transformers. The Dissolved Gas Analysis is a proven and meaningful method for finding a fault as soon as possible if increased proportions of hydrogen and hydrocarbon gases are found in the oil. This way, important preventative maintenance can be performed in time to avoid an unexpected total failure.

DGA analysis and interpretation of results [3.1]

On the left are gases the oil specialist looks for in the gas-in-oil-analysis. On the right are possible origins of these gases. When these gases exceed the levels shown in the middle columns, the analyst uses the transformer history, the type of gases present, as well as the relative amounts, to determine any indication of transformer problems.

	Gas	Normal ppm ¹⁾	Abnormal ppm	
Hydrogen	H ₂	200	500	<p>The diagram illustrates the origins of various gases in transformer oil. It features a vertical rectangular box with several horizontal arrows pointing into it from the left. The arrows are labeled 'Arcing', 'Corona', and 'Overheated Oil'. Below the box, a bracket labeled 'Cellulose' encompasses two horizontal arrows pointing to the right, representing the origin of CO and CO₂.</p>
Acetylene	C ₂ H ₂	5	15	
Methane	CH ₄	50	120	
Ethylene	C ₂ H ₄	80	170	
Ethane	C ₂ H ₆	35	75	
Carbon monoxide ²⁾	CO	200 ¹⁾	500	
Carbon dioxide ³⁾	CO ₂	2000 ²⁾	3500	

Legend:

Major gases 
 Minor gases 

- 1) ppm = parts per million by volume (gas/liquid)
- 2) Previous limits for CO were 500 and 700 ppm
- 3) Previous limits for CO₂ were 2000 and 10000 ppm

Behind the absolute value of gas content are the quotients of the gas components, which also allow for additional information (Table 6-1) [3.2].

Table 6-1 Dissolved Gas Analysis [3.2]

	Type of fault	$\frac{C_2H_2}{C_2H_4}$	$\frac{CH_4}{H_2}$	$\frac{C_2H_4}{C_2H_6}$
PD	Partial discharge	< 0.01	< 0.1	< 0.2
D1	Discharge with low energy	> 1	0.1 - 0.5	> 1
D2	Discharge with high energy	0.6 - 2.5	0.1 - 1	> 2
T1	Thermal fault T < 300°C	< 0.01	> 1	< 1
T2	Thermal fault T < 700°C	< 0.1	> 1	1 - 4
T3	Thermal fault T > 700°C	< 0.2	> 1	> 4

Possible Faults and Possible Findings

Table 6-2 Possible Faults and Possible Findings [3.3]

Key gases	Possible Faults	Possible Findings
H ₂ , possible trace of CH ₄ and C ₂ H ₆ . Possible CO.	Partial discharges (corona)	Weakened insulation from aging and electrical stress
H ₂ , CH ₄ (some CO if discharges involve paper insulation). Possible trace amounts of C ₂ H ₆ .	Low energy discharges (sparking). May be static discharges.	Pinhole punctures in paper insulation with carbon and carbon tracking. Possible carbon particles in oil. Possible loose shield, poor grounding of metal objects.
H ₂ , CH ₄ , C ₂ H ₆ , C ₂ H ₄ and the key gas for arcing C ₂ H ₂ will be present perhaps in large amount. If C ₂ H ₂ is being generated, arcing is still going on. CO will be present if paper is being heated.	High energy discharges (arcing).	Metal fusion (poor contacts in tap changer or lead connections). Weakened insulation from aging and electrical stress. Carbonized oil. Paper destruction if it is in the arc path or overheated.
H ₂ , CO.	Thermal fault less than 300 °C in an area close to paper insulation (paper is being heated).	Discoloration of paper insulation. Overloading and/or cooling problem. Bad connection in leads or tap changer. Stray current path and/or stray magnetic flux.
H ₂ , CO, CH ₄ , C ₂ H ₆ , C ₂ H ₄	Thermal fault between 300 °C and 700 °C.	Paper insulation destroyed. Oil heavily carbonized.
All the above gases and acetylene in large amounts.	High energy electrical arcing. Thermal fault of 700 °C and above.	Same as above with metal discoloration. Arcing may have caused a thermal fault

Transformer Faults

Table 6-3 Transformer Faults [3.3]

Fault	Examples
Partial discharges	Discharges in gas-filled cavities in insulation, resulting from incomplete impregnation, high moisture in paper, gas in oil supersaturation or cavitation (gas bubbles in oil), leading to X wax formation on paper.
Discharge of low energy	Sparking or arcing between bad connections of different floating potential, from shielding rings, toroids, adjacent discs or conductors of different windings, broken brazing, closed loops in the core. Additional core grounds. Discharges between clamping parts, bushing and tank, high voltage and ground, within windings. Tracking in wood blocks, glue of insulating beam, winding spacers. Dielectric breakdown of oil, load tap changer breaking contact.
Discharge of high energy	Flashover, tracking or arcing of high local energy or with power follow-through. Short circuits between low voltage and ground, connectors, windings, bushings and tank, windings and core, copper bus and tank, in oil duct. Closed loops between two adjacent conductors around the main magnetic flux, insulated bolts of core, metal rings holding core legs.
Overheating less than 300°C	Overloading the transformer in emergency situations. Blocked or restricted oil flow in windings. Other cooling problem, pumps valves, etc. Stray flux in damping beams of yoke.

Table 6-3 Transformer Faults [3.3]

Fault	Examples
Overheating 300°C - 700°C	Defective contacts at bolted connections (especially busbar), contacts with tap changer, connections between cable and draw-rod of bushings. Circulating currents between yoke clamps and bolts, clamps and laminations, in ground wiring, bad welds or clamps in magnetic shields. Abraded insulation between adjacent parallel conductors in windings.
Overheating over 700°C	Large circulating currents in tank and core. Minor currents in tank walls created by high uncompensated magnetic field. Shorted core laminations.

Notes on Table :

1. X wax formation comes from paraffinic oils (paraffin based). These are not used in transformers at present in the United States but are predominate in Europe.
2. The last overheating problem in the table says "over 700°C". Recent laboratory discoveries have found that acetyl can be produced in trace amounts of 500°C, which is not reflected in this table. We have several transformers that show trace amounts of acetylene that are probably not active arcing but are the result of high-temperature thermal faults as in the example. It may also be the result of one arc, due to a nearby lightning strike or voltage surge.
3. A bad connection at the bottom of a bushing can be confirmed by comparing infrared scans of the top of a bushing with a sister bushing. When loaded, heat from a poor connection at the bottom will migrate to the top of the bushing, which will display a markedly higher temperature. If the top connection is checked and found tight, the problem is probably a bad connection at the bottom of the bushing.

In addition to the previous table, it should be taken into account that overheating is often caused by bad contacts in the tap selector. In order to find out the reason for high gas values, further tests have to be performed on the transformer.

Common test methods are:

- Winding resistance measurement
- **On-Load Tap Changer (OLTC)** test
- Turns ratio measurement
- Excitation current measurement
- Measurement of leakage reactance
- Capacitance and Dissipation factor measurement

All the mentioned tests can be done with the *CPC 100 + CP TD1*. This instrument is the ideal test and analysis instrument for transformer diagnosis with these measuring possibilities.

6.2 Capacitance and DF Measurement of Transformer Windings

General

- The transformer must be taken out of service and completely isolated from the power system.
- The proper grounding of the transformer tank has to be checked.
- The bushing high-voltage terminals must be isolated from the connection lines.
- All bushing terminals of one winding group, which means A, B, C (and Neutral) of high-voltage winding, A, B, C (and Neutral) of low-voltage

winding and A, B, C (and Neutral) of tertiary winding have to be connected by a copper wire (see Figure 6-1).

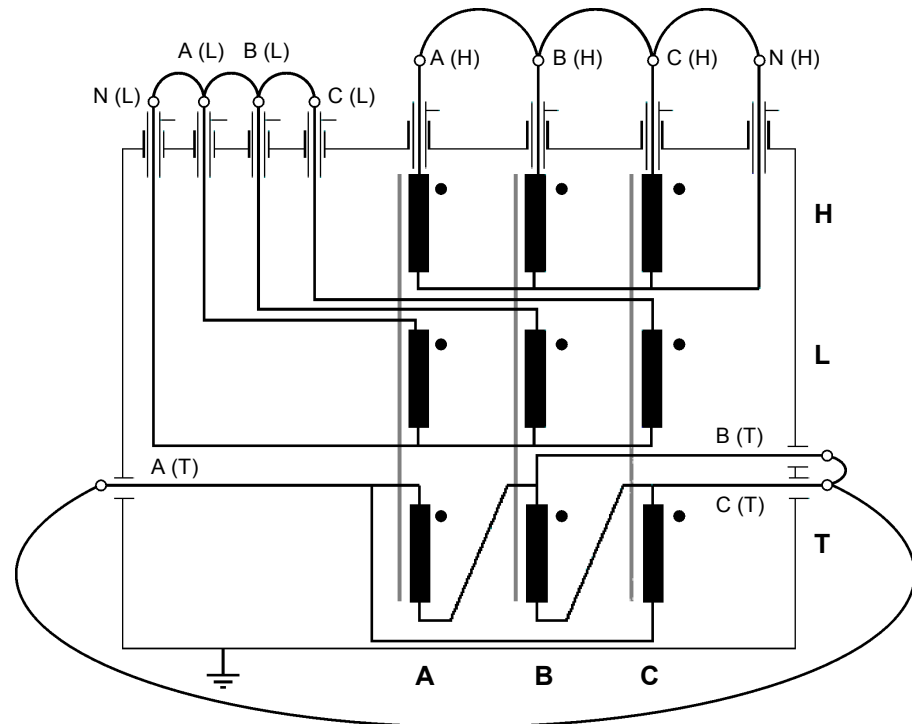

Figure 6-1 Three-winding transformer with connected winding

- The neutral terminals of all Y-connected windings with outside-connected Neutral have to be disconnected from ground (tank).
- If the transformer has a tap changer then it should be set to the neutral position (0 or middle tap).
- Connect the *CPC 100 + CP TD1* ground terminal to the transformer's (substation) ground.
- Connect the high-voltage output of the *CP TD1*, e.g. to the high-voltage winding (according to the connection instructions). Touching any parts

like the bushings and the transformer tank (flashovers) with the unscreened part of the high-voltage test cable must be avoided.

- Connect the IN A, e.g. to the low-voltage winding, IN B, e.g. to the tertiary winding (according to the connection instructions).
- Short circuit all bushing CTs.
- Do not make high-voltage tests on transformers under vacuum.
- The test voltage should be chosen with respect to the rated voltage of the winding.
- All tests should be made with oil temperatures near 20°C. Temperature corrections can be calculated by using correction curves, but they depend a great deal on the insulation material, the water content and many other parameters. This way the correction has limited accuracy.

6.2.1 Three-Winding Transformer

A transformer contains a complicated insulation system. High- and low-voltage windings have to be insulated to the tank and the core (ground) and against each other. All these insulation gaps should be checked regularly. Normally in a two-winding power transformer, C-Tan-Delta measurements are made for all insulation gaps: HV to LV, HV to ground, LV to ground.

A three-winding transformer is much more complicated so more tests are necessary to measure all gaps. In Figure 6-2, a complete 3-winding power transformer is shown. The tertiary winding is not accessible in this case. When the load is unbalanced, it is necessary for flux compensation in the three limbs of the core.

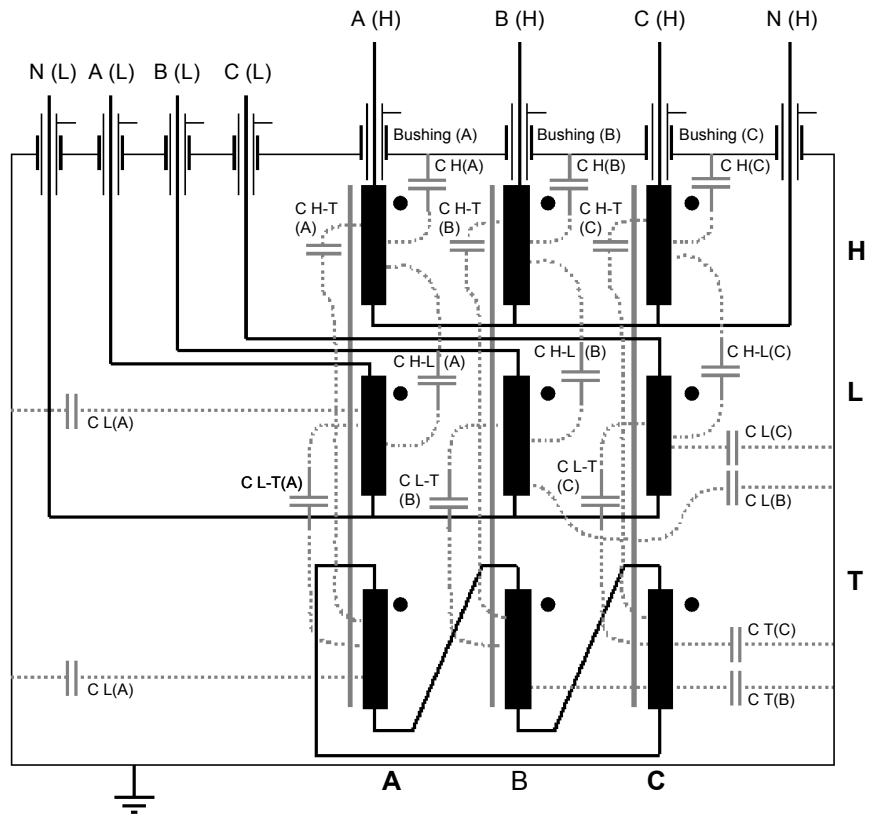

Figure 6-2 Three-winding transformer with winding to winding and winding to ground capacitors

A	Phase A	B	Phase B	C	Phase C
H	High-Voltage winding	C H	Cap. H to Ground	C H-L	Cap. H to L
L	Low-Voltage winding	C L	Cap. L to Ground	C L-T	Cap. L to T
T	Tertiary winding	C T	Cap. T to Ground	C H-T	Cap. H to T

As shown in Figure 6-2, the three phases of the high-voltage (H), the low-voltage (L) and the tertiary (T) windings are connected internally in y or delta. This way only the sum of all three phases can be measured, the single phases can not be measured separately. Figure 6-3 shows the simplified circuit diagram of the three-phase transformer of Figure 6-2.

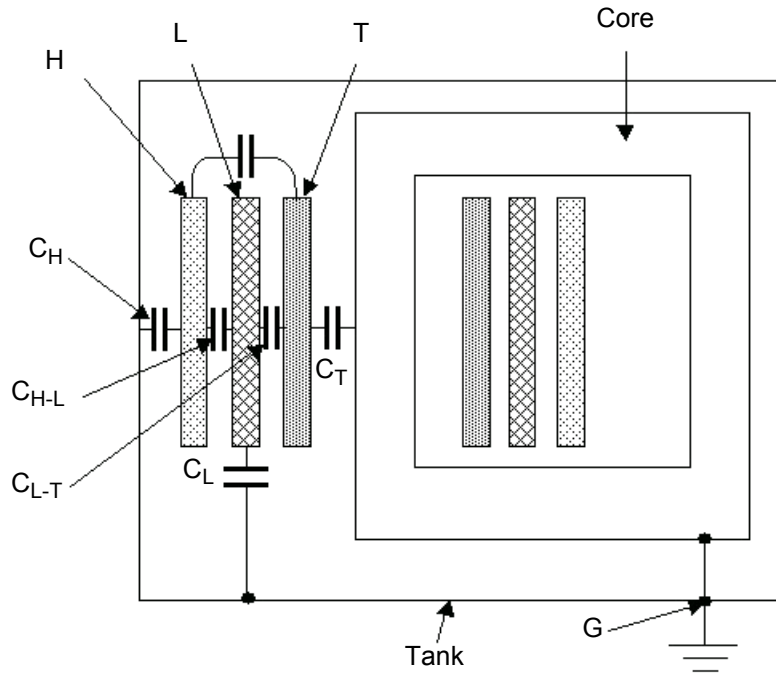

Figure 6-3 Three-phase transformer with winding capacitances

H	High-Voltage winding	C H	Cap. H to Ground	C H-L	Cap. H to L
L	Low-Voltage winding	C L	Cap. L to Ground	C L-T	Cap. L to T

T	Tertiary winding	C T	Cap. T to Ground	C H-T	Cap. H to T
---	------------------	-----	------------------	-------	-------------

To check the winding insulation completely, it is necessary to measure the capacitance and the DF of all insulation gaps (in this case six capacitors).



Caution: All phases and the neutral terminal of one winding (H, L and T) have to be short-circuited. Due to the inductance of the windings resonant effects may occur and influence the measurement.

In IEEE Std. 62-1995 [3.4] the test procedure is described for transformers with two and three windings. Figure 6-4 shows the six measurements.

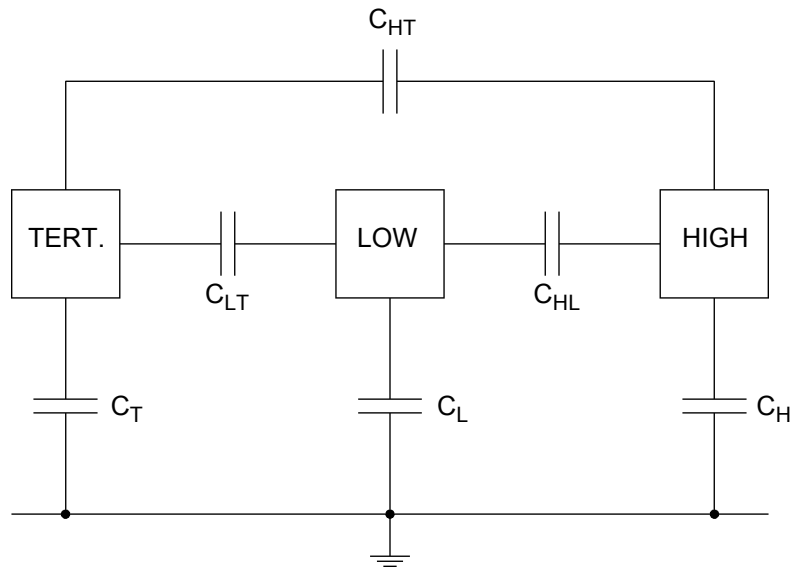

Figure 6-4 Three-winding transformer test according to IEEE 62-1995

Test Mode	Energize	Ground	Guard	UST	Measure
GST	HIGH	-	LOW, TERT.	-	C_H
GST	LOW	-	TERT., HIGH	-	C_L
GST	TERT.	-	HIGH, LOW	-	C_T

Supplementary test for interwinding insulations

UST	HIGH	TERT.	–	LOW	C _{HL}
UST	LOW	HIGH	–	TERT.	C _{LT}
UST	TERT.	LOW	–	HIGH	C _{HT}

A more detailed test procedure for two- and three- winding transformers can be found in [3.6]. This test procedure is included in the appendix and is now used as an example to show the test preparation of a 3-winding transformer test with

the CPC Editor. Due to the high amount of measuring data, the test is split into three single test files. The first file contains the tests with high-voltage winding connected to the *CP TD1* high-voltage output:

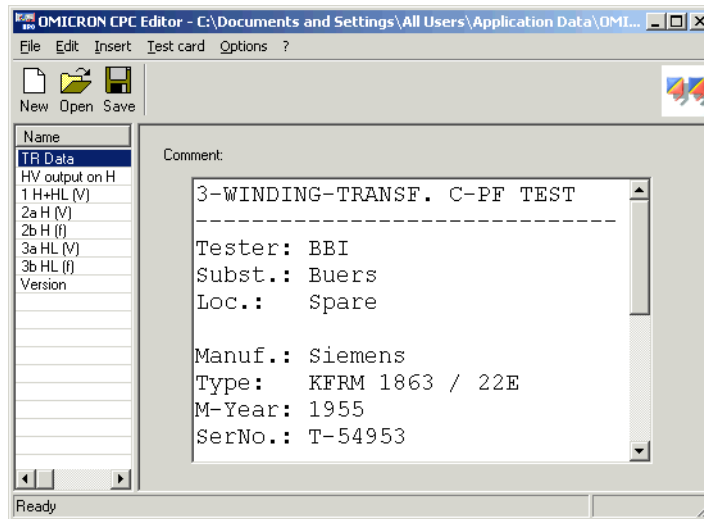

Figure 6-5 Input of transformer data

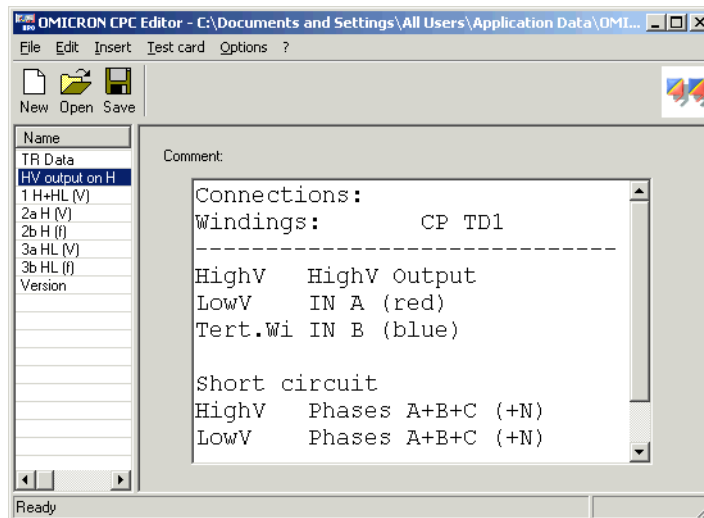

Figure 6-6 Instruction about test lead connections

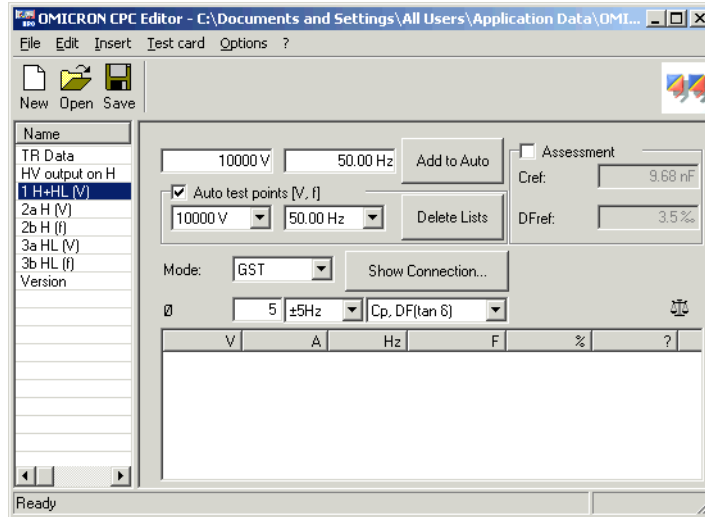

Figure 6-7 Measurement of C H and C H-L in GST g-B mode

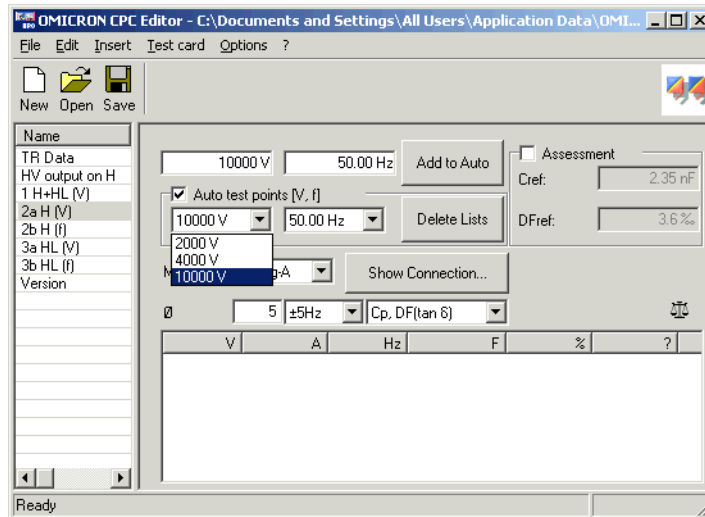

Figure 6-8 Voltage-scan of high-voltage windings to tank and core (GST gA+B)

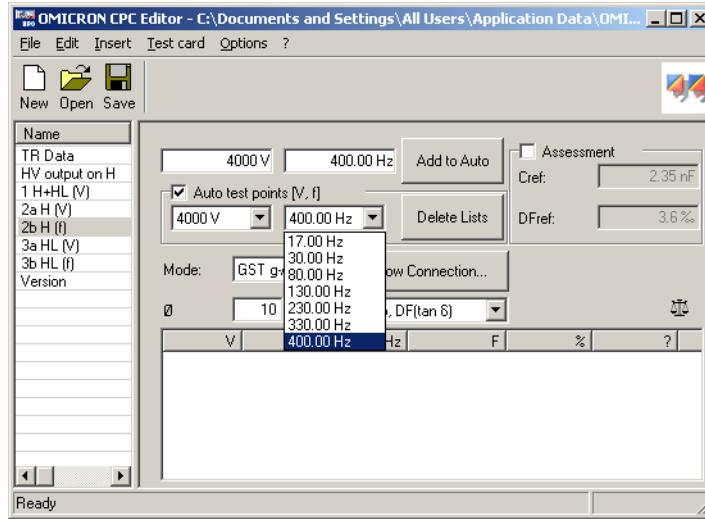

Figure 6-9 Frequency-scan of high-voltage windings to tank and core (GST gA+B)

The other tests for H-L are prepared analog to the examples.

A second test file contains the tests with the low-voltage winding connected to the high-voltage output of the *CP TD1*. Figure 6-10 shows the first screen with the connection instructions.

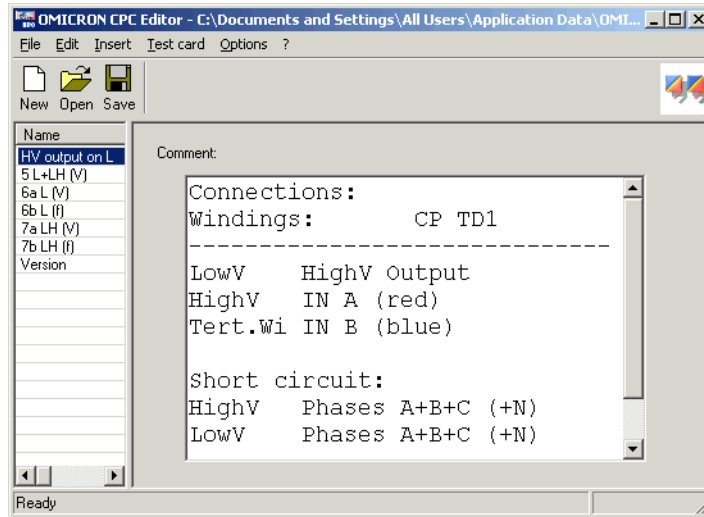

Figure 6-10 Connection instructions for the tests with energized low-voltage winding

A third test file is used for the tests with the tertiary winding connected to the *CP TD1* high-voltage output. 6-11 shows the connection instructions for the tests with energized tertiary winding.

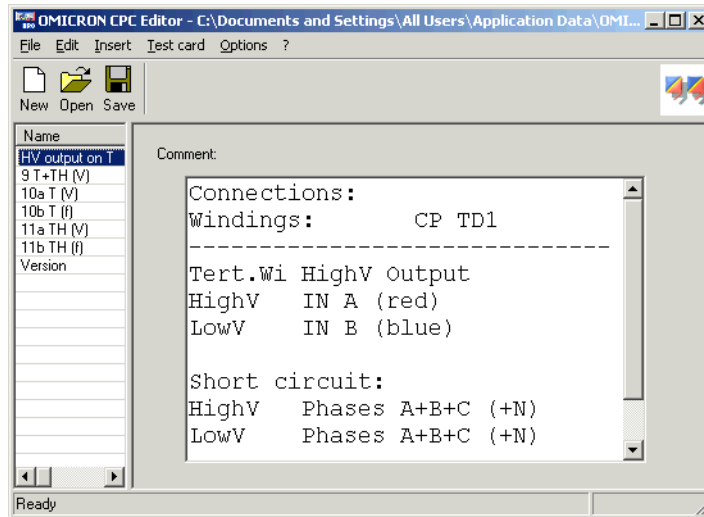

Figure 6-11 Connection instructions for the tests with energized tertiary winding

The prepared tests are uploaded to the *CPC 100* as xml files without results. After the test is done, this xml file with the results is downloaded to the computer and loaded into Microsoft Excel with the *OMICRON CPC 100 File Loader* (the complete test files are included on the CD-ROM).

#	HV output	Ground	Guard	UST	V TEST [V]	I TEST [A]	C	DF [%] measured	DF [%] corrected	Measured	Mode	Connection
1	H	L	T		10019,0	0,0303	9,611E-09	0,3065	0,3065	H + HL	GST gB	H to HV OUT
2	H		L + T		10019,0	0,0278	8,835E-09	0,2633	0,2633	H	GST gA+B	L to IN A
3	H	T		L	9999,0	0,0024	7,739E-10	0,4319	0,4319	HL	UST A	T to IN B
4	#1 - #2							7,755E-10				
5	L	T	H		10019,0	0,0306	9,710E-09	0,2753	0,2753	L + LT	GST gA	L to HV OUT
6	L		T + H		10000,0	0,0278	8,835E-09	0,2627	0,0000	L	GST gA+B	H to IN A
7	L	H		T	10015,0	0,0027	8,736E-10	0,0840	0,0840	LT	UST B	T to IN B
8	#5 - #6							8,746E-10				
9	T	H	L		5002,0	0,0151	9,611E-09	0,3056	0,3056	T + TH	GST gB	T to HV OUT
10	T		H + L		4999,0	0,0139	8,835E-09	0,2761	0,2761	T	GST gA+B	H to IN A
11	T	L		H	4999,0	0,0012	7,739E-10	0,4349	0,4349	TH	UST A	L to IN B
12	#9 - #10							7,761E-10				

V TEST max. = 1.2 x V RATED

Figure 6-12 10 kV results for a three-winding transformer (50 Hz)

Figure 6-12 shows the results for 10 kV:

- 1: H+HL
- 2: H
- 3: HL
- 5: L+LT
- 6: L
- 7: LT
- 9: T+TH
- 10: T
- 11: TH

In line 4, the difference of the capacity values of test 1 - test 2 is calculated so it can be compared to test 3. In lines 8 and 12, the differences of lines 5-6 and 9-10 are calculated to also enable a comparison to tests 7 and 11. This way the reliability of the measured values can be checked. For the tertiary winding, the test voltage was reduced to 5 kV due to the lower rated voltage of this winding.

A voltage scan measurement is shown in Figure 6-13, a frequency scan in Figure 6-14.

Voltage and frequency scans enable additional information about the insulation quality. They should be saved as "fingerprint" for future measurements. For all the described measurements only three different connections of the test leads are necessary. Preparing the test in the office by utilizing the *CPC Editor*, the testing time on-site can be reduced to a minimum.

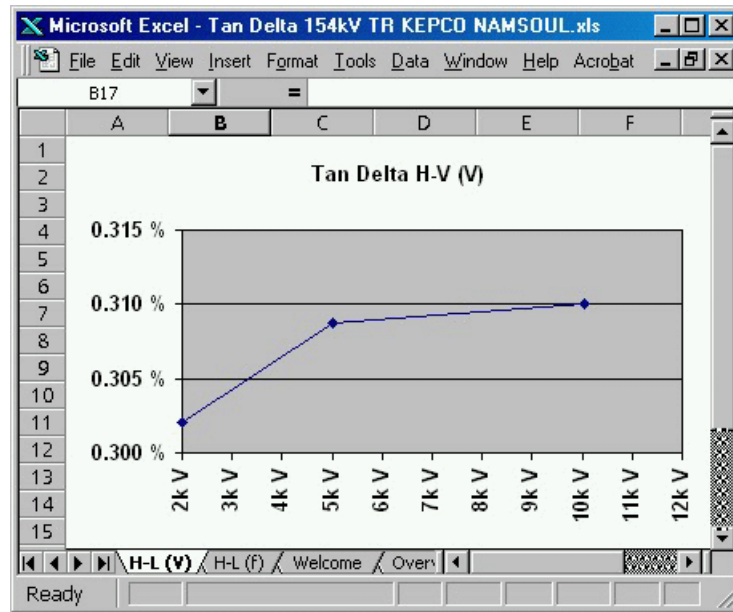

Figure 6-13 Voltage-scan for H-L (V) (50 Hz)

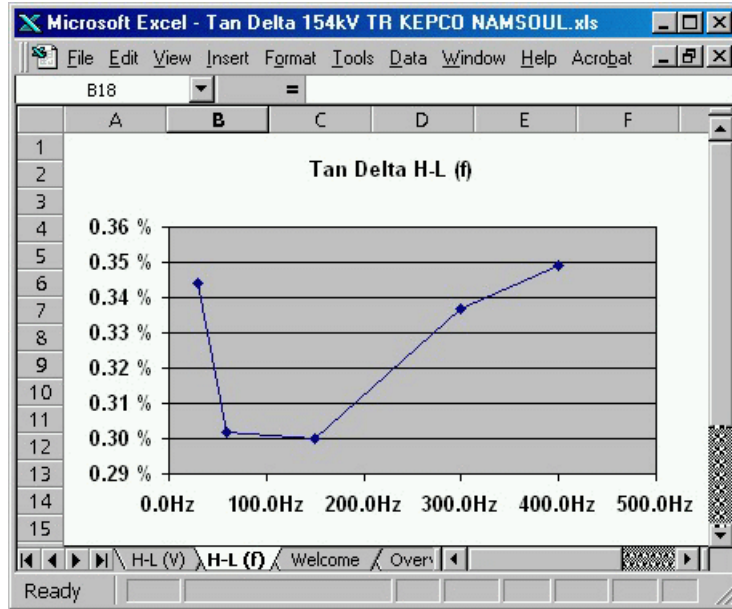

Figure 6-14 Frequency scan for H-L (f) (5 kV)

6.2.2 Two-Winding Transformer

The test of two-winding transformers is easier than the described test procedure for transformers with three windings. Figure 6-15 shows the simplified circuit diagram of a two-winding transformer.

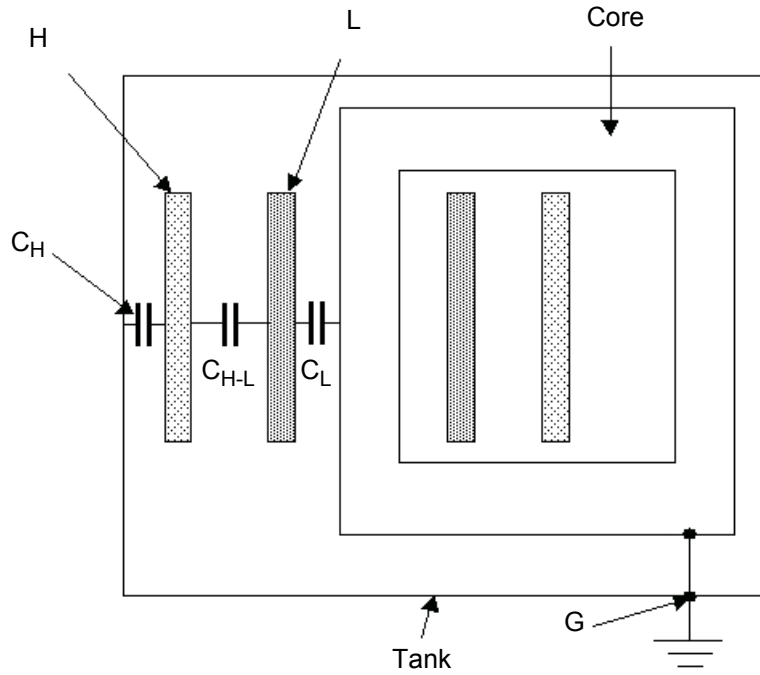

Figure 6-15 Two-winding transformer with winding capacitances

H	High-Voltage winding	C H	Cap. H to Ground	C H-L	Cap. H to L
L	Low-Voltage winding	C L	Cap. L to Ground	C L-T	Cap. L to T

In Figure 6-16, the test procedure for a two-winding transformer is shown, according to IEEE 62 1995 [3.4].

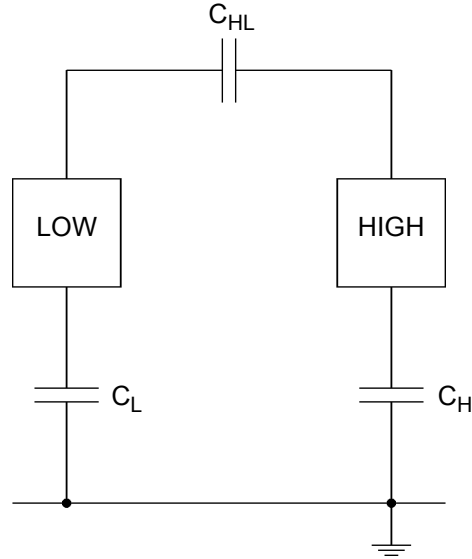

Figure 6-16 Two-winding transformer test according to IEEE 62-1995

Test Mode	Energize	Ground	Guard	UST	Measure
GST	HIGH	-	LOW	-	C_H
GST	LOW	-	HIGH	-	C_L
Alternative test for C_{HL}					
UST	HIGH	-	-	LOW	C_{HL}
UST	LOW	-	-	HIGH	C_{HL}

Figures 6-17 and 6-18 show the preparation with the *CPC Editor* and the test results in MS Excel format.

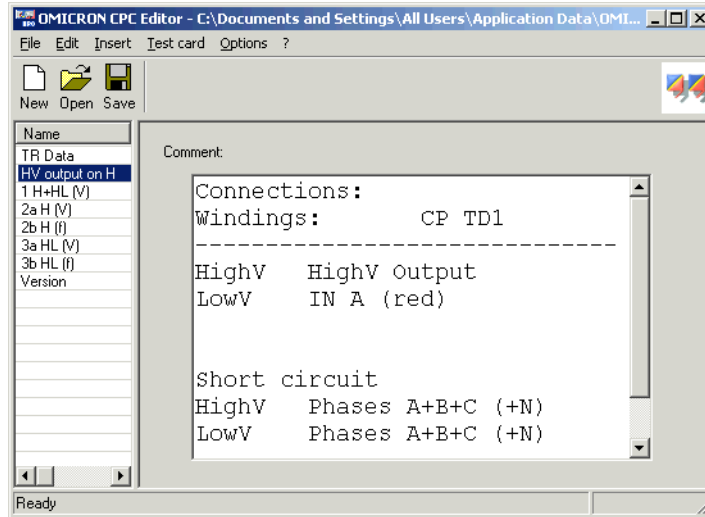

Figure 6-17 Two-winding transformer test preparation with *CPC Editor*

#	HV output	Ground	Guard	UST	V TEST [V]	I TEST [A]	C	DF[%] measured	DF[%] corrected	Mode	Connection
1	H	L			9999,00	0,0329	1,048E-08	0,3066	0,3066	H+HL	H to HV OUT
2	H		L		10000,00	0,0305	9,708E-09	0,2661	0,2661	H	GST gA
3	H			L	9999,00	0,0024	7,739E-10	0,4257	0,4257	HL	UST A
4			#1 - #2				7,763E-10				
5	L	H			10018,00	0,0306	9,708E-09	0,2499	0,2499	L	GST gA

Figure 6-18 10 kV results for a two-winding transformer (50 Hz)

6.2.3 Auto-Transformer

The auto-transformer has only one winding with a tap for the low-voltage output. Only one measurement is made of the winding to tank and core. All high-voltage and low-voltage terminals are connected together as they are building the high-voltage electrode of the capacity.

6.2.4 Reactors

Similar to the auto-transformers, reactors also normally have only one winding. Often the low-voltage ends of the three phases are connected outside the tank to the Neutral. In this case we have 2 bushings per phase, which have to be connected for the DF test. We can measure all combinations: phase to phase and phase to tank (ground).

6.3 Transformer High-Voltage Bushing Tests

High-voltage bushings are generally used in power transformers, but also in circuit breakers and in other electrical apparatus. Therefore, the test of bushings is described in chapter 7 "Capacitance and DF Measurement on High-Voltage Bushings" on page 91.

6.4 Interpretation of Measurement Results

Initial tests on new transformers when it arrives from the manufacturer determines the presence of manufacturing defects or transport damage, and also provides "fingerprint" test values for future comparisons. Periodic tests during the life cycle of the transformer can indicate that the insulation is aging normally or rapidly.

6.4.1 Dissipation Factor Measurement

Environmental Conditions

As already mentioned in chapter 5 "Capacitance and Dissipation Factor Measurement" on page 39, environmental factors can influence DF measurements greatly. Therefore it is important to record the ambient conditions at the time of testing when comparing test results. The tests should be made with oil temperatures near 20°C. Temperature corrections can be calculated, utilizing correction curves, but they depend very much on the insulation material, the water content and a lot of other parameters. This way the correction has limited accuracy. Testing at temperatures below freezing should be avoided, since the measurement results are not reliable. If the water in the insulation is frozen to ice, it may not be detected by DF testing.

Other factors like relative humidity and the general weather conditions should be recorded in the test report for future reference.

For oil paper insulation, the range of the DF values for new and aged transformers are published in some standards like [3.4] and in other literature [3.1], [3.2]. In IEEE Std. 62-1995 [3.1] the following limits for DF values are given:

Table 6-4 DF values for oil paper insulation

Transformer	Condition of insulation		
	Good	May be acceptable	Should be investigated
New	DF < 0.5%	-	-
Service-aged	DF < 0.5%	0.5% < DF < 1%	DF > 1%
All values measured at 20 °C			

It is always better to measure the values regularly and save them for comparison to tests in the past and in the future. In this way, trends can be observed and the evaluation of results is of much higher quality.

6.4.2 Capacitance Measurement

The capacitance of the insulation gaps between the windings to each other and to ground depends mainly on the geometry of the winding. Windings may be deformed after transport of the transformer or nearby through faults with high currents. Changes in capacitance serve as an excellent indicator of winding movement and structural problems (displaced wedging, buckling etc.). If a winding damage is suspected then the capacitance measurement should be supplemented by a leakage reactance measurement. A separate test can be done for each phase with this measurement technique. Therefore this method is more sensitive to small changes in one phase.

6.5 References

- [3.1] US Bureau of Reclamation: "Maintenance of liquid insulation mineral oils and Askarels", Facility instructions, standards and techniques - Vol. 3-5, 1992
- [3.2] Möllmann, A., Lütge, H.: IEC / VDE Standards für flüssige Isolierstoffe zur Diagnostik von Transformatoren und Wandlern, ETG-Fachbericht "Diagnostik elektrischer Betriebsmittel", VDE-Verlag GmbH Berlin 2002, S. 205-210

- [3.3] US Bureau of Reclamation: "Transformer Maintenance", Facility instructions, standards and techniques - Vol. 3-30, 2000
- [3.4] ANSI Standard 62-1995: "IEEE Guide for Diagnostic Field testing of Electric Power Apparatus - Part 1: Oil Filled Power Transformers, Regulators, and Reactors", IEEE New York, 1995
- [3.5] US Bureau of Reclamation: "Transformer Diagnostics", Facility instructions, standards and techniques - Vol. 3-31, 2003
- [3.6] IEEE Standard C57.12.90: "IEEE Standard Test Code for Liquid-Immersed Distribution, Power, and Regulating Transformers", IEEE New York, 1995

7 Capacitance and DF Measurement on High-Voltage Bushings

7.1 Introduction

High-voltage bushings are essential parts of power transformers, circuit breakers and of other power apparatus. More than 10% of all transformer failures are caused by defective bushings [4.2]. Although the price for a bushing is low compared to the costs of a complete transformer, a bushing failure can damage a transformer completely. A regular capacitance and DF measurement is highly recommended.

7.2 Types of Bushings

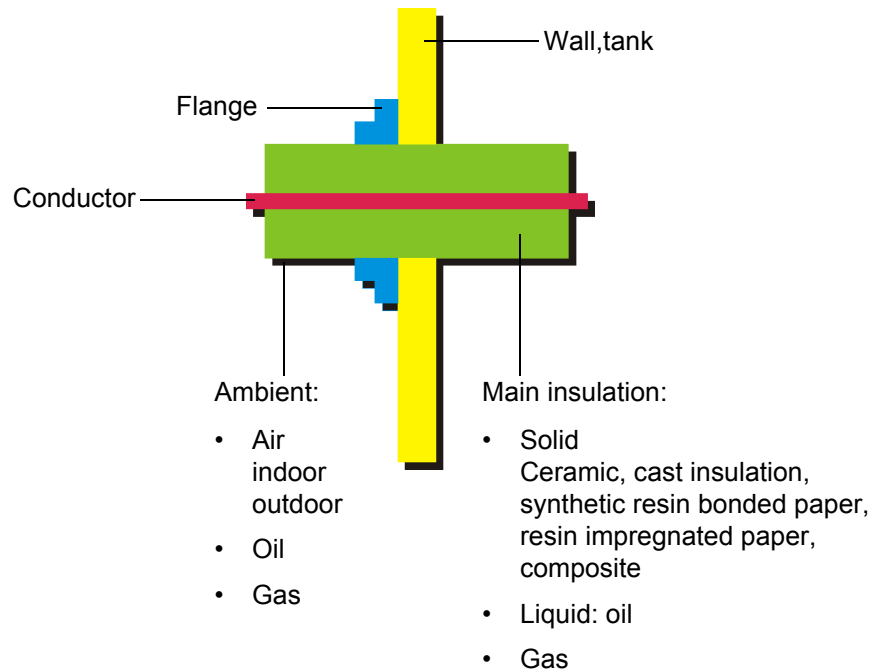

Figure 7-1 Principle of bushings

Testing and maintaining high-voltage bushings are essential for continued successful operation of transformers and circuit breakers. Power outages may occur as the result of a bushing failure. High-voltage bushings used on transformers and breakers exist in many forms, including:

Condenser

This type is most frequently used for high-voltage bushings and it is therefore the main one focused in this guide. Cylindrical conducting layers are arranged coaxially with the conductor within the insulating material. The length and diameter of the cylinders are designed to control the distribution of the electric field in and over the outer surface of the bushing. The partial capacities are switched in series and the voltage drops across the capacities is nearly equal to each other (Figures 7-2 and 7-3) [4.1].

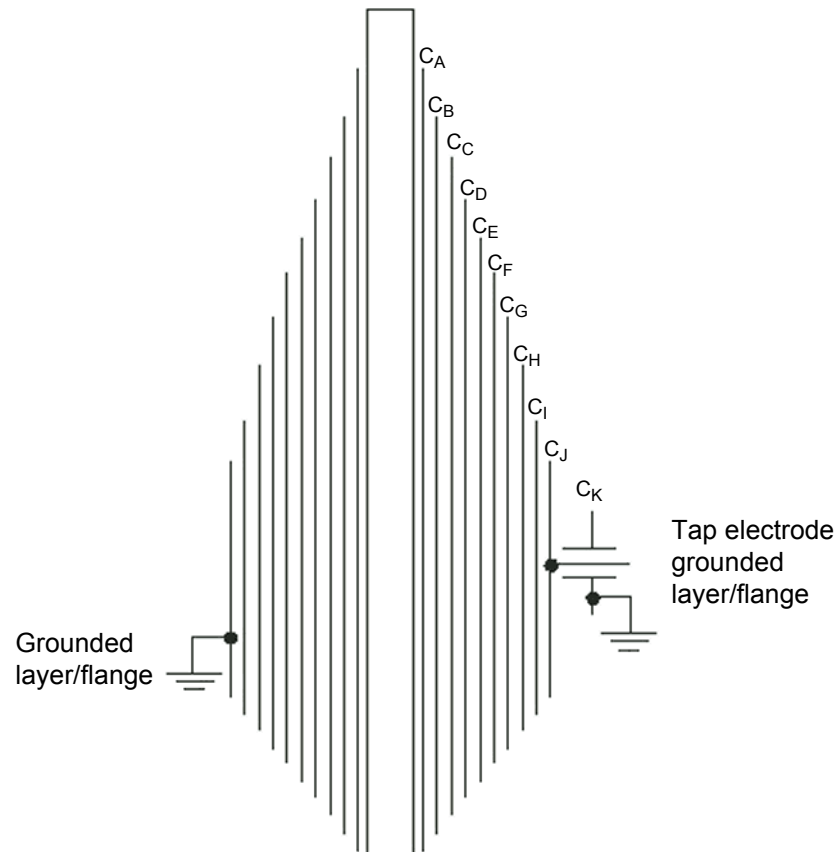

Figure 7-2 Condenser bushing design [4.1]

Notes:

- Equal capacitances, C_A through C_J , procedure equal distribution of voltage from the energized center conductor to the grounded condenser layer and flange.
- The tap electrode is normally grounded in service except for certain designs and bushings used with potential device.
- For bushings with potential taps, the C_2 capacitance is much greater than C_1 . For bushings with power-factor tap, C_1 and C_2 capacitances may be same order of magnitude.

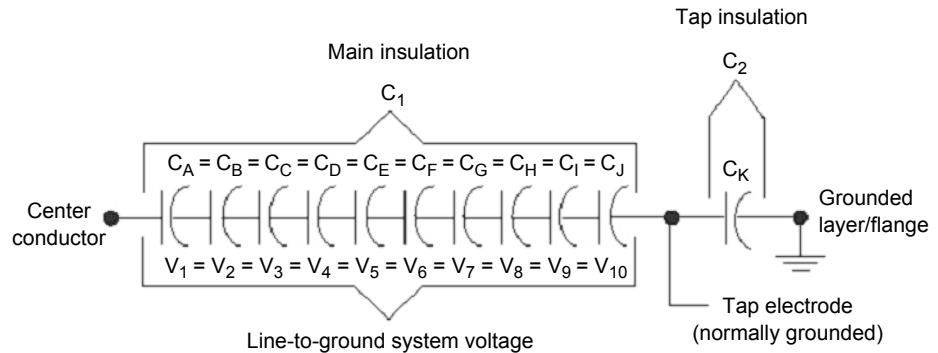

Figure 7-3 Condenser bushing circuit diagram [4.1]

Condenser bushings may have:

- "Resin-Bonded Paper insulation (RBP)
- "Resin-Impregnated Paper insulation (RIP)
- "Oil-Impregnated Paper insulation (OIP)

Composite

A bushing where the insulation consists of two or more coaxial layers consisting of different insulating materials.

Compound-filled

A bushing where the space between the major insulation or conductor, if no major insulation is used, and the inside surface of a protective weather casing (usually porcelain) is filled with a compound that contains insulating properties.

Dry or unfilled

A bushing consisting of a porcelain tube with no filler in the space between the shell and the conductor. These are usually rated 25 kilovolts and below.

Oil-filled

A bushing where the space between the major insulation or the conductor, and the inside surface of a protective weather casing is filled with insulating oil.

Oil-immersed

A bushing composed of major insulators that are totally immersed in a bath of insulating oil.

Oil-impregnated paper-insulated

A bushing where the internal structure is made of cellulose material impregnated with oil.

Resin-bonded paper-insulated

A bushing where cellulose material bonded with resin provides the major insulation.

Solid, ceramic

A bushing where a ceramic or other similar material provides the major insulation.

Gas insulated

A bushing that contains compressed gas like SF₆ or mixtures of SF₆ with other gasses i.e. N₂. This type is frequently used for circuit breaker bushings.

7.3 Bushing Troubles

About 90 percent of all preventable bushing failures are caused by moisture entering the bushing through leaky gaskets or other openings. Periodic inspection and diagnostic measurements can prevent most outages due to bushing failures. High-voltage bushings may explode with considerable violence and cause extensive damages to adjacent equipment. Flashovers may be caused by deposits of dirt on the bushings, particularly in areas where there are contaminants such as salts or conducting dusts in the air. These deposits should be removed by periodic cleaning. In [4.3] bushings faults, possible reasons and methods of detection are explained (Table 7-1).

Table 7-1 Bushing faults, part 1 [4.3]

Failure	Possible results	Methods of detection
Cracked porcelain	Moisture enters; Oil and/or gas leaks; Filler leaks out	Visual inspection; Power factor test; Hot-collar test
Deterioration of cemented joints	Moisture enters; Oil and/or gas leaks; Filler leaks out	Visual inspection; Power factor test; Hot-collar test
Gasket leaks	Moisture enters; Oil and/or gas leaks; Filler leaks out	Visual inspection; Power factor test; Hot-collar test; Hot-wire test for moisture; Insulation resistance
Moisture in insulation	Moisture enters	Power factor test; Hot-collar test
Solder seal leak	Moisture enters; Filler leaks out	Visual inspection; Power factor test; Hot-collar test; Hot-wire test for moisture; Leak detector
Broken connection between ground sleeve and flange	Sparking in apparatus tank or within bushing; Discolored oil	Power factor test; Uncharacteristic odor; Dissolved gas-in-oil analysis (DGA); Thermographic scanning
Voids in compound	Internal corona	Visual inspection; Power factor test; Hot-collar test
Displaced grading shield	Internal sparking discolors oil	Hot-collar test; Uncharacteristic odor; Thermographic scanning; Dissolved gas-in-oil analysis (DGA)
Electrical flashover	Cracked or broken porcelain; Complete failure	Visual inspection; Hot-collar test

Table 7-1 Bushing faults, part 1 [4.3]

Failure	Possible results	Methods of detection
Lightning	Cracked or broken porcelain; Complete failure	Visual inspection; Test lightning arresters
Corona	Internal breakdown; Radio interference; Treeing along surface of paper or internal surfaces	Power factor test; Hot-collar test; Hot wire test; Radio-influence voltage (RIV) test; Thermographic scanning; Dissolved gas-in-oil analysis (DGA)
Short-circuited condenser sections	Increased capacitance; Reduced voltage at capacitance tap terminal; Adds internal stress to insulation	Power factor test; Voltage test at capacitance tap; Capacitance test; Thermographic scanning; Dissolved gas-in-oil analysis (DGA)
Darkened oil	Radio interference; Poor test results	Power factor test; Hot-collar test

7.4 Capacitance and DF Measurement on High-Voltage Bushings

The dissipation factor test is the most effective known field test procedure for the early detection of bushing contamination and deterioration. It also measures alternating (AC) test current, which is directly proportional to bushing capacitance.

Bushing dissipation factor and capacitance should be measured when a bushing is first installed and also one year after installation. After these initial measurements, bushing power or dissipation factor and capacitance should be measured at regular intervals (3 to 5 years typically). The measured values should be compared with previous tests and nameplate values.

Note: Large variations in temperature significantly affect dissipation factor readings on certain types of bushings. For comparative purposes, readings should be taken at the same temperature. Corrections should be applied before comparing readings taken at different temperatures.

Bushings may be tested by one or more of four different methods, depending upon the type of bushing and the dissipation factor test set available. For more detailed instructions on this test procedure, see the dissipation factor test set instruction book from the appropriate manufacturer. The four test methods are described as follows:

7.5 Ungrounded Specimen Test (UST)

This test measures the insulation between the center conductor and the capacitance tap, the dissipation factor tap, and/or ungrounded flange of a bushing. This test may be applied to any bushing in or out of the apparatus that is either equipped with capacitance or dissipation factor taps, or with the flange that can be isolated from the grounded tank in which the bushing is installed. The insulation resistance between the taps or insulated flanges and ground should be 0.5 M or greater. While in this case anything that is attached to the bushing would also be energized, only the insulation of the bushing between the center conductor and the ungrounded tap or flange would be measured. In the case of bushings equipped with capacitance taps, a supplementary test should always

be made on the insulation between the tap and the flange. Most manufacturers list the UST dissipation factor and capacitance values on the bushing nameplate.

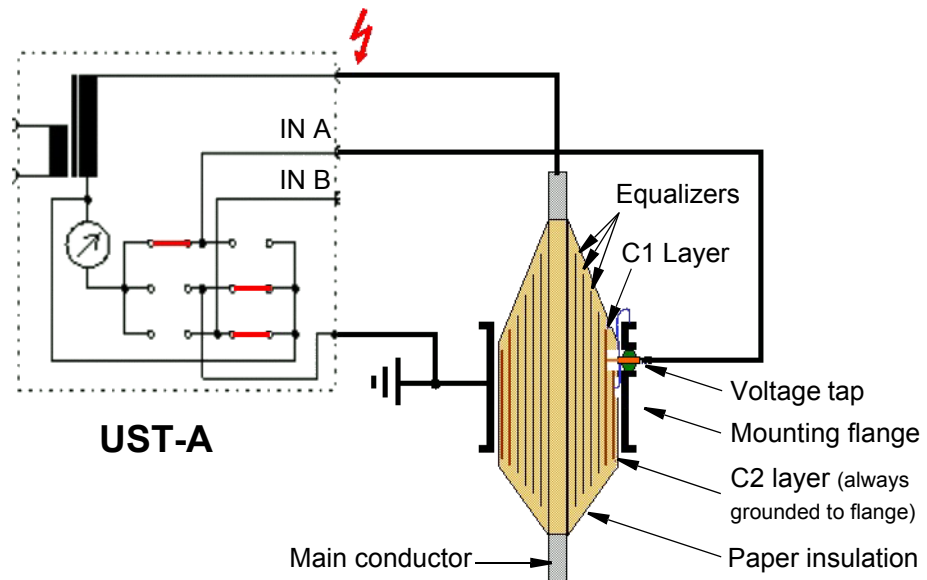

Figure 7-4 UST bushing test (C1)

When bushings with capacitance or potential taps rated at 110 kV and above are tested by the ungrounded test specimen method, a separate dissipation factor test on the tap insulation should be performed as well.

For capacitance or potential taps, tests are performed at a voltage between 500 and 1,000 volts. The tap is energized with the bushing center conductor and flange grounded. The dissipation factor of a capacitance or potential tap will generally be of the order of 1.0 percent or less. Routine tap insulation tests are not normally recommended for bushings that are rated 69 kilovolts and below with dissipation factor taps. However, a dissipation factor test of the tap insulation should be performed when UST results are questionable or visual examination indicates the dissipation factor tap's condition is questionable. This test procedure is similar to that used earlier for capacitance taps. In such cases, the maximum permissible test potentials should be limited to those given in the

appendix or as recommended by the bushing manufacturer. The dissipation factor value of the dissipation factor tap insulation for most of the bushings discussed earlier is generally in the order of 1.0 percent or less.

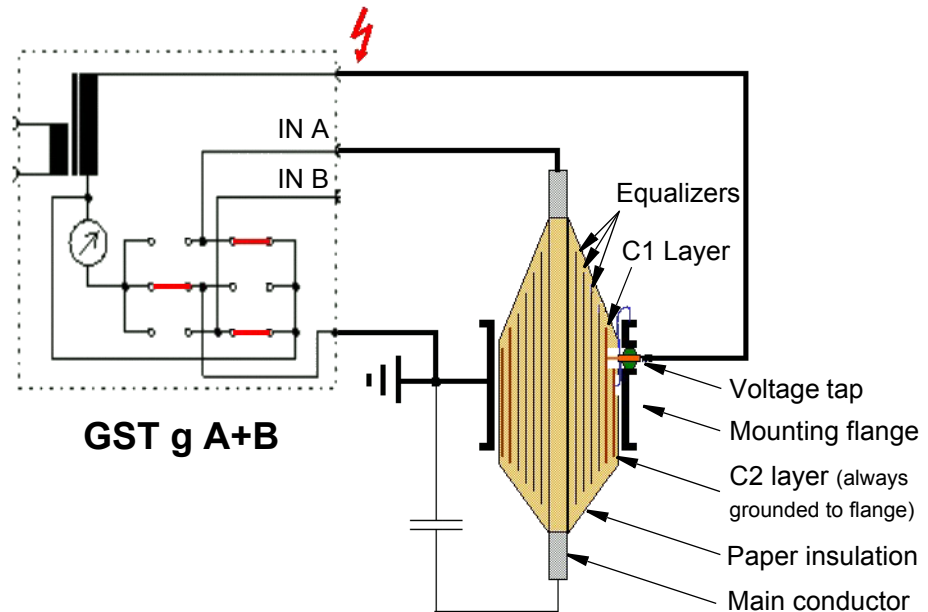

Figure 7-5 GST bushing test (C2)

7.6 Grounded Specimen Test (GST)

This test measures the quality of the insulation between the current carrying or center conductor and the mounting flange of a bushing. This test is conducted on bushings that have been removed from equipment, bushings connected to de-energized equipment, spare bushings, or bushings that have been isolated from connected windings and interrupters. The test is performed by energizing the bushing conductor and grounding the flange.

7.7 Hot Collar Test

This test measures the condition of a specific small section of bushing insulation between an area of the upper porcelain rain shed and the current carrying or center conductor. The test is performed by energizing one or more electrodes placed around the bushing porcelain with the bushing center conductor grounded. This test is used to supplement the three previous tests. It is also

used to test bushings in apparatus when the three tests are either inapplicable or impractical, such as, with SF6 bushings. Perform a hot-collar test at every third skirt on SF6 bushings. Hot-collar tests are effective in locating cracks in porcelain, deterioration, or contamination of insulation in the upper section of a bushing, low compound or liquid level, or voids in compound often before such defects are noticeable with the previous tests.

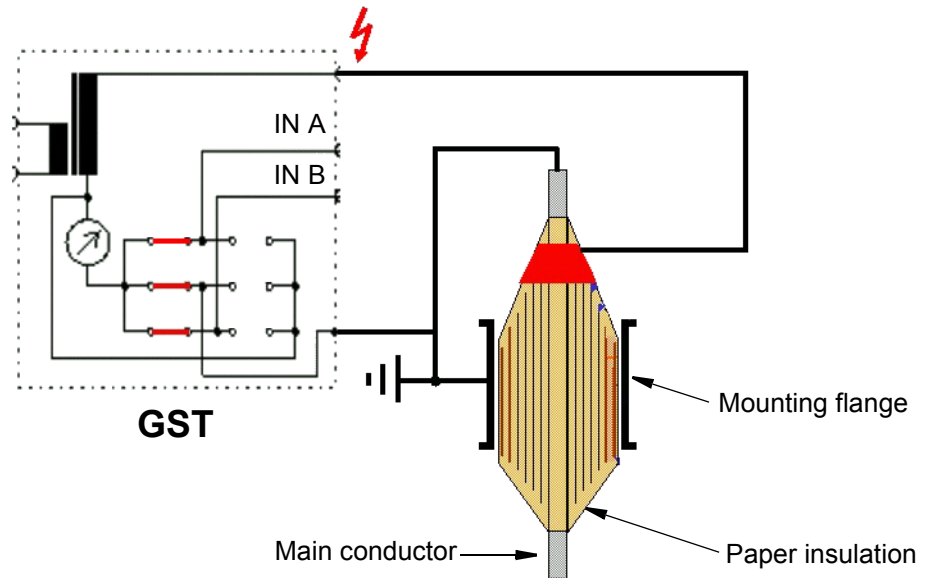

Figure 7-6 Bushing "hot collar" test

In tables of the appendix, typical dissipation factors and dissipation factor the manufacturers initially published limits. However, the typical or initial dissipation factor of many bushings is listed on the nameplate. In such cases, field measurement, particularly UST, should compare with the nameplate dissipation factors. In general, any bushing that exhibits a history of continuing increase in dissipation factor should be questioned and scheduled for removal from service.

Measured dissipation factor values should be temperature corrected to 20°C before being compared with reference values which are measured at 20°C.

Temperature correction factors are average values at best, and therefore, subject to some error. The magnitude of error is minimized if tests are performed at temperatures near the reference temperature of 20°C. If questionable dissipation factors are recorded at relatively high temperatures then the bushings should not be condemned until it has been allowed to cool down to near 20°C and repeat tests have been performed. This also applies to bushings

tested near freezing where a large (greater than 1.00) correction may cause the result to be unacceptably high; in this case the equipment should be retested at a higher temperature. Bushing should not be tested when their temperatures are much below freezing because moisture may have changed to ice, which has a significantly higher volumetric resistivity and therefore be undetected. In the case of bushings mounted in transformers, taking the average between the ambient and transformer top-oil temperatures approximates the bushing temperature.

Bushing capacitance should be measured with each power or dissipation factor test and compared carefully with both nameplate and previous tests in assessing bushing condition. This is especially important for capacitance-graded bushings where an increase in capacitance of 5% more over the initial/nameplate value is cause to investigate the suitability of the bushing for continued service. The manufacturer should be consulted for guidance on specific bushings.

When the relative humidity is high, measurements are often influenced by the current, which is flowing on the surface of the insulator. Sometimes these currents are in the same order than the current, which is flowing through the insulation or even higher. If a good cleaning and drying of the insulator surface is not sufficient, the guard technique should be used to bypass this current, see Figure 7-7.

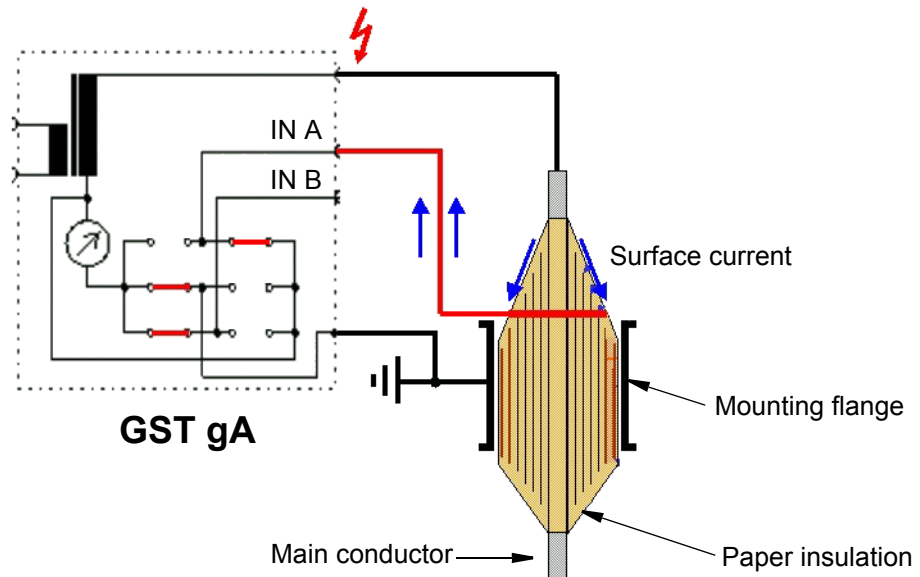

Figure 7-7 Use of guard method for bypassing the surface current

This connection technique is also very useful when the insulation of cables is measured.

When transformer bushings are tested, inputs A and B can be used to measure two bushings at a time without rewiring:

Test	UST A (IN A)	UST B (IN B)
1	Phase A	Phase B
2	Phase C	Neutral

Frequency scans of bushing insulation are helpful for a better diagnosis. Figure 7-8 shows a frequency scan of a new RIP bushing, Figure 7-9 of an aged one. This additional information should be used as benchmark of the bushing for future comparison.

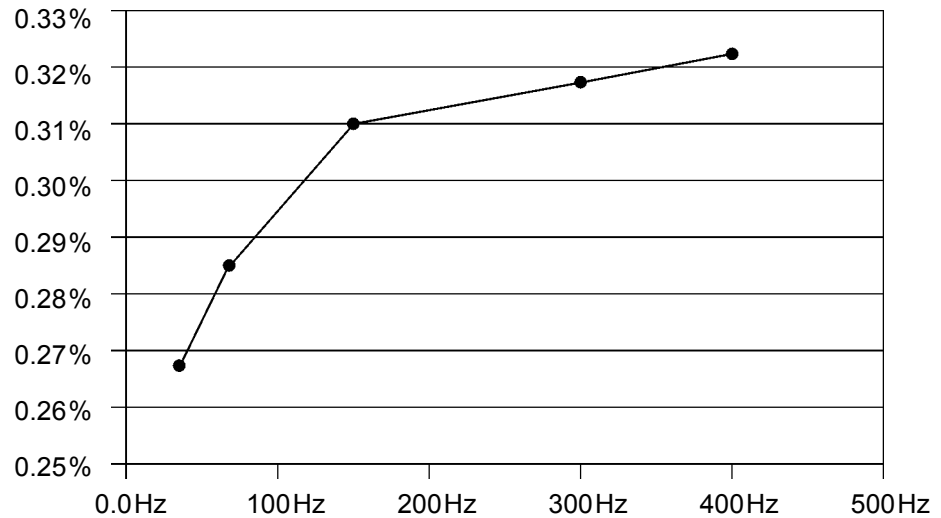

Figure 7-8 Frequency scan of a new RIP bushing

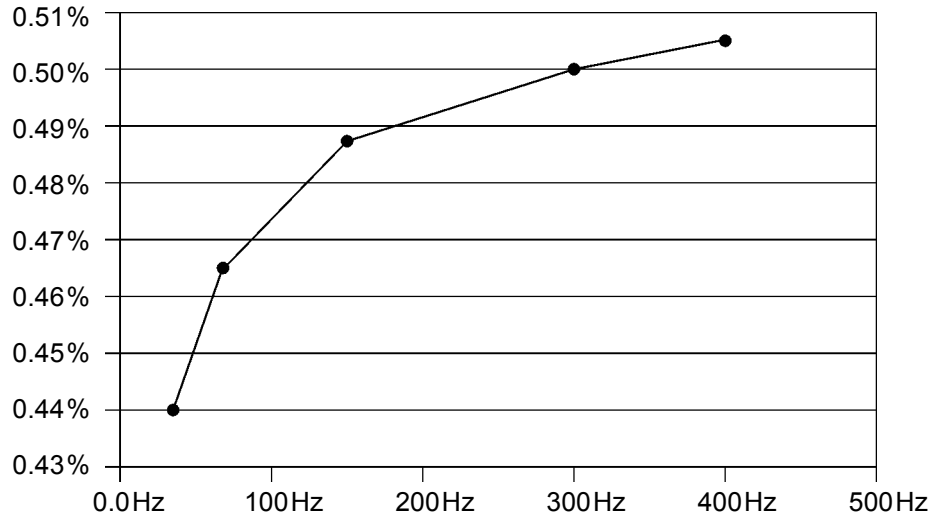

Figure 7-9 Frequency scan of an aged RIP bushing

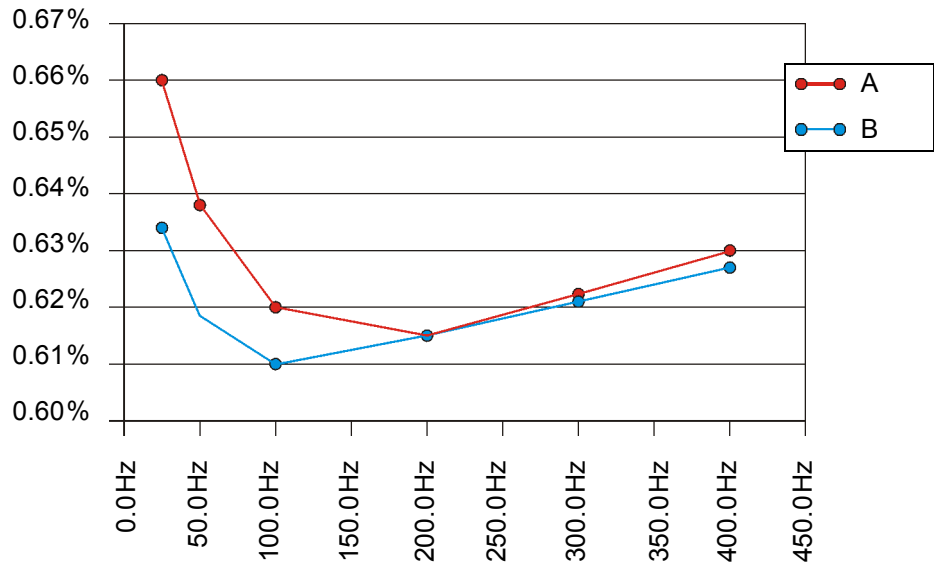

Figure 7-10 Frequency scan of an OIP bushing (Phase A and B)

7.8 Interpretation of Measurement Results

In the appendix typical DF values and limits are listed. Figures 7-11 and 7-12 show the aging of RBP, RIP and OIP bushings [4.5].

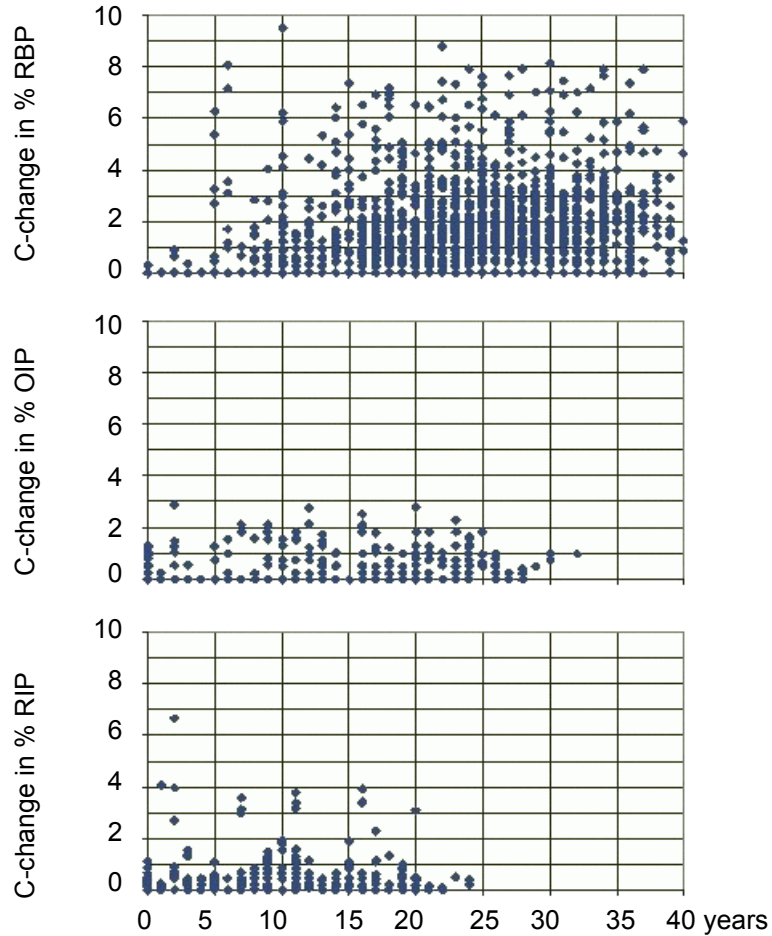

Figure 7-11 Aging of RBP, RIP and OIP bushings (change of capacitance)

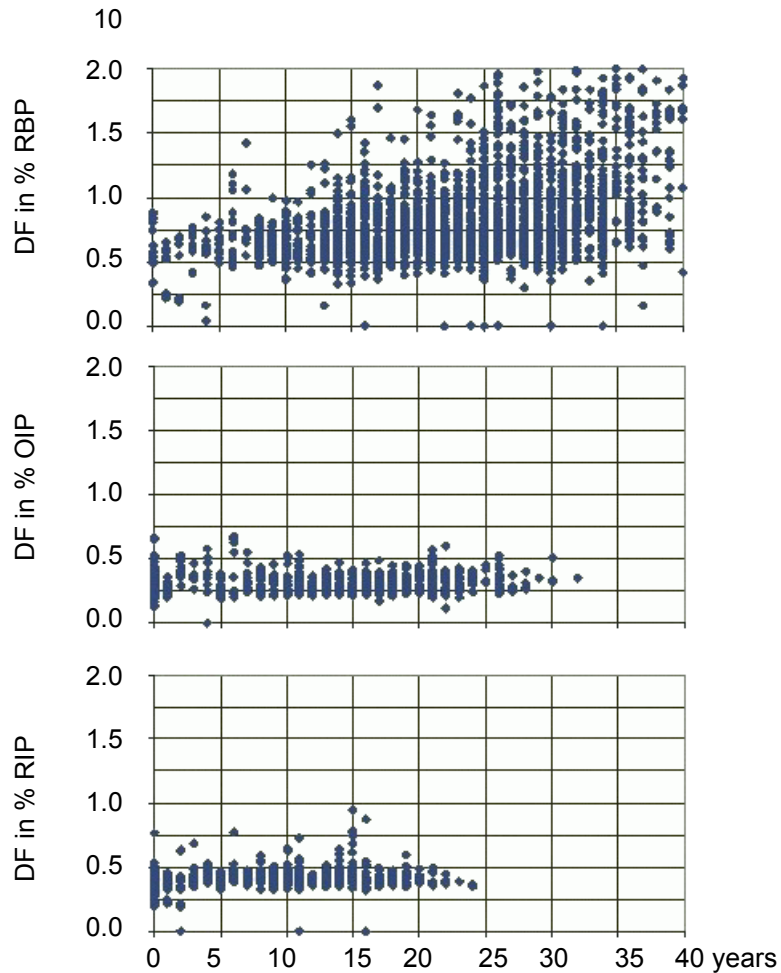

Figure 7-12 Aging of RBP, RIP and OIP bushings (change of DF)

RBP bushings show a significant change of capacitance and dissipation factor.

In [4.6] RBP, RIP and OIP bushings were analyzed over more than 30 years (Figures 7-13 and 7-14). What is important are the curves for the upper limits, which were found.

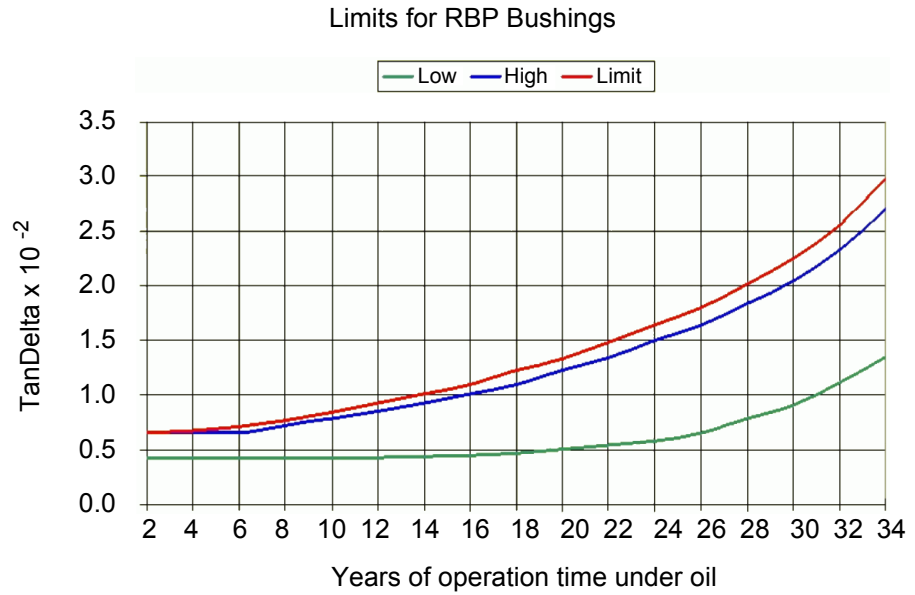

Figure 7-13 Limits for RBP bushings

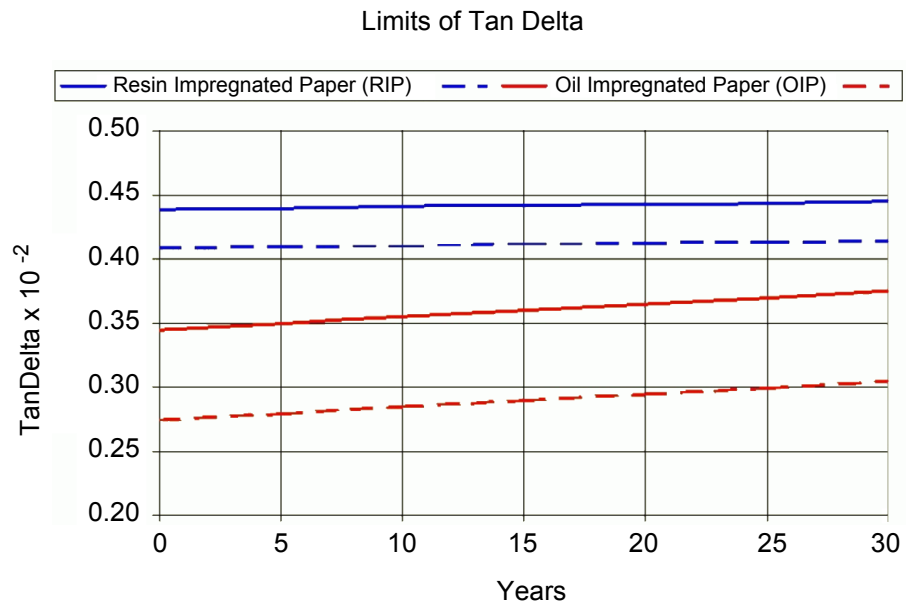

Figure 7-14 RBP bushings - Limits of Tan Delta

General guidelines for evaluating the C_1 capacitance data are as follows:

Table 7-2 General guidelines for evaluating the C_1 capacitance data

$\Delta C = C_{\text{measured}} - C_{\text{ref}}^*$	Evaluation:
$\Delta C < 5\%$	Acceptable
$5\% < \Delta C < 10\%$	Should be investigated
$\Delta C > 10\%$	Critical
* with C_{ref} = nameplate value or value for new bushing	
	Evaluation:
$DF_{\text{meas}} < 2 \times DF_{\text{ref}}$	Acceptable
$DF_{\text{meas}} < 3 \times DF_{\text{ref}}$	Should be investigated
$DF_{\text{meas}} > 3 \times DF_{\text{ref}}$	Critical
* with DF_{ref} = nameplate value or value for new bushing	

7.9 References

- [4.1] ANSI Standard 62-1995: "IEEE Guide for Diagnostic Field testing of Electric Power Apparatus - Part 1: Oil Filled Power Transformers, Regulators, and Reactors", IEEE New York, 1995
- [4.2] CIGRE-WG 12-05: An international survey on failures in large power transformers in service, Electra No. 88 1983, S. 21-48
- [4.3] US Bureau of Reclamation: "Testing and Maintenance of High Voltage Bushings", Facility instructions, standards and techniques - Vol. 3-2, Denver, 1991
- [4.4] Schurman, D.: Testing and maintenance of high voltage bushings, Western Area Power administration, Golden (Colorado), 1999
- [4.5] Sundermann, U.: "Transformer life cycle management" 1.Symposium Geriatrie des Transformators, Regensburg 2002

- [4.6] Seitz, V.: Vorbeugende Instandhaltung an Leistungstransformatoren – Betriebsbegleitende Messungen an Stufenschaltern und Durchführungen, OMICRON Anwendertagung 2003, Friedrichshafen

8 Capacitance and DF Measurement of Generators and Motors

The DF - voltage characteristic (power- factor tip-up) of stator windings is used primarily as a quality-control criterion in manufacturing high-voltage generators and motors. It is sometimes used as an acceptance test on individual coils. DF tip-up has been used as a maintenance test because a change in the tip-up value over a period of time is an indication of change of condition of the coil insulation. With increasing test voltage Partial Discharges (PD) may occur. This can be seen in Figure 8-1. The sensitivity of the power-factor tip-up test decreases with the length of coil included in the measurement.

Refer to IEEE Standard No. 286, July 1975, "IEEE Recommended Practice for Measurement of Power-Factor Tip-Up of Rotating Machinery Stator Coil Insulation", for a description of the DF tip-up test. A DF tip-up curve of a 6kV motor is shown in Figure 8-1.

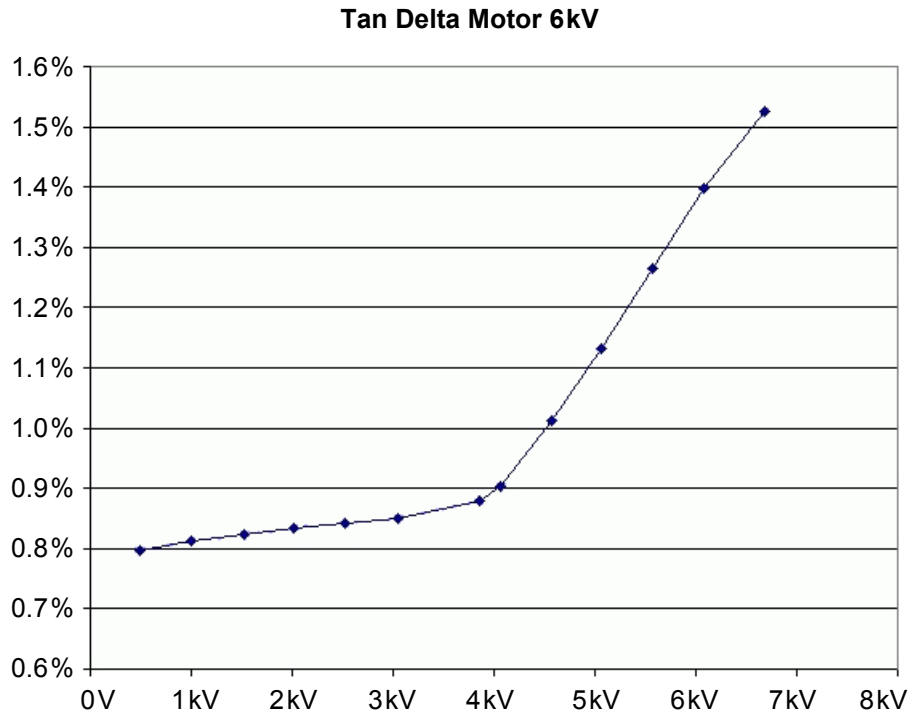

Figure 8-1 DF tip-up curve

The maximum output power of the *CP TD1* is 3600 VA, that means, capacitance values up to 80nF (50Hz) respectively 66nF (60Hz) can be measured. Bigger capacitors can be tested at lower voltages, or with a reactor switched in parallel to the capacitance of test object. In any case a first test should be carried out with a small voltage to measure the capacitance before applying high voltage.

9 Capacitance and DF Measurement of Circuit Breakers

9.1 Introduction

The most common types of Circuit-Breakers (CB) are:

- Oil Circuit-Breakers (OCB's) in dead tank design
- Oil poor Circuit Breakers in life tank design
- Air-Blast Circuit-Breakers
- SF6 Circuit-Breakers
- Vacuum Circuit-Breakers
- Air Magnetic Circuit-Breakers
- Oil Circuit Reclosers

Power and dissipation factor testing provides a means of verifying the integrity of the insulation. Circuit breakers in dead tank design have high-voltage bushings, the test is described in chapter 7 "Capacitance and DF Measurement on High-Voltage Bushings" on page 91.

9.2 Oil Circuit Breakers (Dead Tank)

Dead tank oil circuit breakers are composed of a steel tank filled with insulating oil. A typical three-phase oil circuit breaker has six bushings. Three bushings channel the three-phase line currents to a set of fixed contacts. Three movable contacts, actuated simultaneously by an insulated rod, open and close the circuit. When the circuit breaker is closed, the line current for each phase penetrates the tank by way of one bushing, flows through the first fixed contact, the moveable contact, the second fixed contact, and then out by the second bushing. The most important insulation in medium and high-voltage outdoor power switchgear is that of the bushings themselves, the guide assembly, the lift rods, and, in the case of oil breakers, the oil. Measurements should be made from each bushing terminal to the tank ground with the breaker open and from each phase (each pair of phase bushing terminals) to the grounded tank with the breaker closed.

Test Connections

There are six overall tests performed when the breaker is open. Each bushing is individually tested in the overall GST test mode. Three overall tests are performed with the breaker closed in the GST test mode. If the bushing is equipped with a test tap, the C₁ main insulation test can be performed in the UST mode along with the overall GST test without making a lead change.

All tests are performed at 10kv or a lower voltage suitable for the insulation.

9.3 Oil Poor Circuit Breakers (Live Tank)

Oil poor circuit breakers with one contact (chamber) per phase normally have vertical tubes out of porcelain with the breaker contacts inside. The DF of the contact chamber can be measured, if the contacts are open. This way the oil quality and decomposition of the oil can be determined.

Oil poor CB's with more than one contact per phase are normally mounted in Y or T form. Grading capacitors in parallel to the contacts equalize the voltage drop across the contacts if they are open. These capacitors have to be removed when the oil quality in the chambers is tested. The capacitance values of the described capacitors are important for a proper operation of the circuit breaker. An increase of the capacitance value is an indicator for partial breakdowns of some sections.

High DF readings on grading capacitors may be the result of deteriorated grading capacitors or, in some cases, surface leakage.

9.4 SF6 Circuit Breakers (Dead Tank with Bushings)

For these CB's the test of the bushing is of importance.

Additional Hot-Collar tests may be conducted on breakers equipped with gas-filled bushings to detect internal contamination or exterior cracks and other problems that may have occurred along the surface of the bushing.

9.5 Vacuum Circuit Breakers

These circuit breakers operate on a different principle from other breakers because there is no gas to ionize when the contacts open. They are hermetically sealed so consequently they are silent and never become polluted. Their interrupting capacity is limited to about 30kv. For higher voltages, several circuit breakers are connected in series.

Charging currents are expected to be small. Under dry ambient conditions, power factor results will be small and dielectric losses close to zero.

Higher than normal UST measurement could be due to a defective vacuum bottle allowing moisture to enter or surface leakage across the vacuum housing. Clean the surface of the vacuum bottle and retest. Ensure that all cabinet heaters are working to maintain a sufficient temperature surrounding the vacuum bottles.

9.6 Air Magnetic Circuit Breakers

The tests and test modes on air-magnetic circuit breakers are conducted in the same manner as the vacuum circuit breakers.

9.7 Oil Circuit Reclosers

The testing of oil circuit reclosers is performed in the same manner as the testing of oil circuit breakers.

10 Capacitance and DF Measurement of Overvoltage Arresters

The purpose of a surge (lightning) arrester is to limit the over voltages that may occur across transformers and other electrical apparatus due either to lightning or switching surges. The upper end of the arrester is connected to the line or terminal that has to be protected, while the lower end is solidly connected to ground. The arrester is composed of an external tube out of porcelain or compound tubing containing an arrangement of stacked discs that are composed of a silicon carbide or metal oxide material. This material has a resistance that decreases dramatically with increasing voltage.

Arresters are effectively switching devices that serve as an insulator under normal conditions and as a conductor under over voltage conditions. After an over voltage condition is cleared, the arrester must return to its normal insulating condition. The measurement of capacitance and resistance is an effective method of evaluating the integrity of an arrester and isolating potential failure hazards. This test reveals conditions that could affect the protective functions of the arrester, such as the presence of moisture or salt deposits.

Temperature

It is recommended to measure the capacitance and the resistance of the arrester at the same temperature as the measurement that was made as a benchmark.

Voltage

The measurement should be made exactly at the same voltage level that the fingerprint measurement was made. Normally the test voltage is 10 kV.

Figures 10-1, 10-2, and 10-3 show the dissipation factor, the capacitance and the parallel resistance of a lightning arrester, dependent on the frequency.

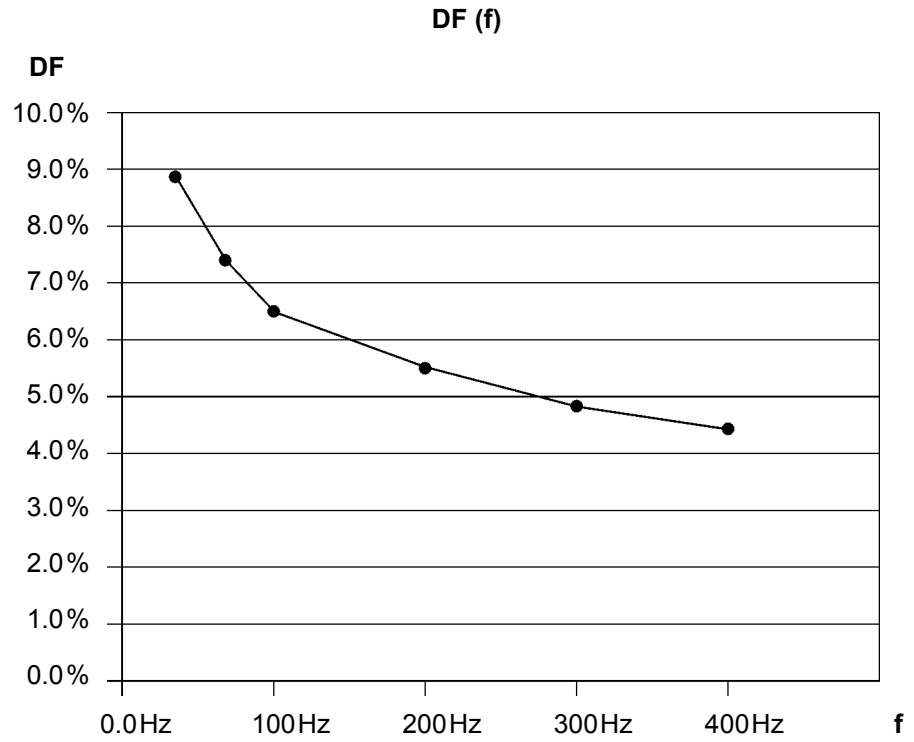

Figure 10-1 Lightning arrester DF (f)

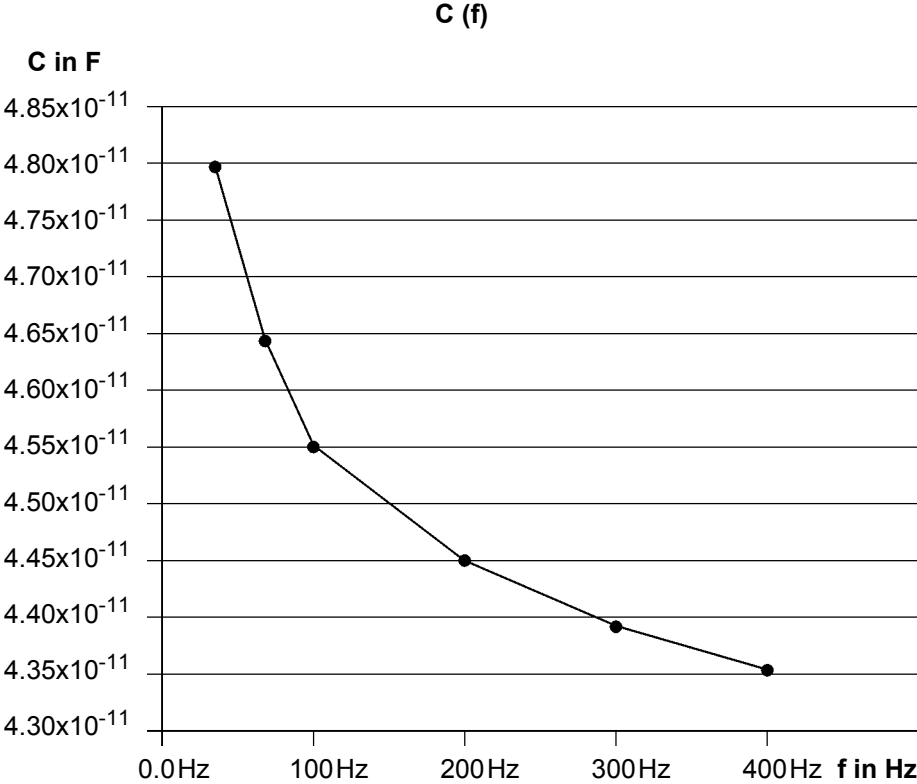

Figure 10-2 Lightning arrester C (f)

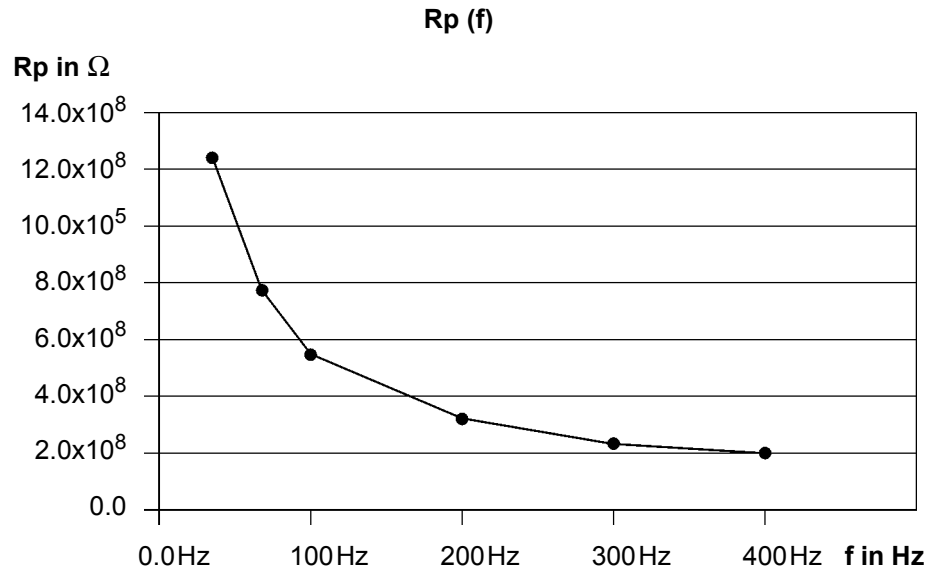

Figure 10-3 Lightning arrester Rp (f)

11 Technical Data

11.1 Technical Data of the *CP TD1* in Combination with the *CPC 100*

11.1.1 High-Voltage Output

Conditions: Signals below 45Hz with reduced values possible. Capacitive linear loads.

Terminal	U / f	THD	I	S	t _{max}
High volt. output	10 ... 12kV AC	< 2%	300mA	3600VA	> 2min
	15 ... 400Hz		100mA	1200VA	> 60min

11.1.2 Measurements

Test frequencies

Range	Resolution	Typical accuracy
15 ... 400Hz	0.01Hz	error < 0.005% of reading

TanDelta test card: Column "Hz" of the results table

Special displays in the frequency column "Hz" and their meanings:

- *50Hz (*60Hz) Measurement mode suppressing the mains frequency interferences; doubles the measurement time.
- !30Hz The selected test voltage is not available in Automatic measurement (applies to frequencies below 45Hz only).
- ?xxHz Results with reduced accuracy, e.g., in case of a low testing voltage, influences of partial discharge etc.

Filter for selective measurements

Conditions: f₀ = 15 ... 400Hz

Filter Bandwidth	Meas. time	Stop band specification (attenuation)
f ₀ ± 5Hz	2.2s	> 110dB at f _x = f ₀ ± (5Hz or more)

$f_0 \pm 10\text{Hz}$	1.2s	> 110dB at $f_x = f_0 \pm (10\text{Hz or more})$
$f_0 \pm 20\text{Hz}$	0.9s	> 110dB at $f_x = f_0 \pm (20\text{Hz or more})$

Test current (RMS, selective)

Terminal	Range	Resolution	Typical accuracy	Conditions
IN A or IN B ¹	0 ... 5A AC	5 digits	error < 0.3% of reading + 100nA	$I_x < 8\text{mA}$
			error < 0.5% of reading	$I_x > 8\text{mA}$

1. IN A (red) or IN B (blue), depending on the mode.

Test voltage (RMS, selective)

Range	Resolution	Typical accuracy
0 ... 12000V AC	1V	error < 0.3% of reading + 1V

Capacitance Cp (equivalent parallel circuit)

Range	Resolution	Typical accuracy	Conditions
1pF ... 3μF	6 digits	error < 0.05% of reading + 0.1pF	$I_x < 8\text{mA}$, $V_{\text{test}} = 300\text{V} \dots 10\text{kV}$
		error < 0.2% of reading	$I_x > 8\text{mA}$, $V_{\text{test}} = 300\text{V} \dots 10\text{kV}$

Dissipation factor DF ($\tan \delta$)

Range	Resolution	Typ. accuracy	Conditions
0 ... 10% (capacitive)	5 digits	error < 0.1% of reading + 0.005% ¹	$f = 45 \dots 70\text{Hz}$, $I < 8\text{mA}$, $V_{\text{test}} = 300\text{V} \dots 10\text{kV}$
0 ... 100 (0...10000%)	5 digits	error < 0.5% of reading + 0.02%	$V_{\text{test}} = 300\text{V} \dots 10\text{kV}$

1. Reduced accuracy of DF at mains frequency or its harmonics. Mains frequency suppression available by precisely selecting a mains frequency of *50Hz or *60Hz in the "Hz" column.

Power factor PF (cos φ)

Range	Resolution	Typ. accuracy	Conditions
0 ... 10% (capacitive)	5 digits	error < 0.1% of reading + 0.005% ¹	f = 45 ... 70Hz, I < 8mA, V _{test} = 300V ... 10kV
0 ... 100%	5 digits	error < 0.5% of reading + 0.02%	V _{test} = 300V ... 10kV

1. Reduced accuracy of PF at mains frequency or its harmonics. Mains frequency suppression available by precisely selecting a mains frequency of *50Hz or *60Hz in the "Hz" column.

Phase angle φ

Range	Resolution	Typ. accuracy	Conditions
-90° ... +90°	4 digits	error < 0.01°	V _{test} = 300V ... 10kV

Impedance Z

Range	Resolution	Typ. accuracy	Conditions
1k Ω ... 1200M Ω	6 digits	error < 0.5% of reading	V _{test} = 300V ... 10kV

Inductance Lx (equivalent serial circuit)

Range	Resolution	Typ. accuracy
1H ... 1000kH	6 digits	error < 0.3% of reading

Quality factor QF

Range	Resolution	Typ. accuracy
0 ... 1000	5 digits	error < 0.5% of reading + 0.2%
> 1000	5 digits	error < 5% of reading

Power P, Q, S (selective)

Range	Resolution	Typ. accuracy
0 ... 3.6kW	6 digits	error < 0.5% of reading + 1mW
0 ... 3.6kvar	6 digits	error < 0.5% of reading + 1mvar
0 ... 3.6kVA	5 digits	error < 0.5% of reading + 1mVA

Weight and dimensions

		Weight	Dimensions (W x H x D)
<i>CP TD1</i>	test set	25kg (55.2lbs)	450 x 330 x 220mm (17.7 x 13 x 8.7") without handles
	test set & case ¹	38.1kg (84lbs)	700 x 500 x 420mm (27.5 x 19.7 x 16.5")
<i>CP CAL1</i>	test set	8.8kg (19.4lbs)	450 x 330 x 220mm (17.7 x 13 x 8.7") without handles
	test set & case ¹	21kg (46.3lbs)	700 x 500 x 420mm (27.5 x 19.7 x 16.5")
Cables and accessories	equipment	16.6kg (36.6lbs)	
	equipment & case ¹	26.6kg (58.7lbs)	680 x 450 x 420mm (26.8 x 17.7 x 16.5")
Equipment trolley	equipment	14.5kg (32lbs)	
	equipment & carton	18.9kg (41.7lbs)	590 x 750 x 370mm (23.2 x 29.2 x 14.6")
<i>CP TD1, CPC 100,</i> equipment & trolley (without <i>CP CAL1</i>)	equipment	85kg (187.5lbs)	750 x 1050 x 600mm (29.5 x 41.3 x 23.6")
	equipment & packing	125kg (275.8lbs)	

1. Case = robust case, IP22

11.2 Environmental Conditions

Table 11-1 Climate

Characteristic		Rating
Temperature	Operating	-10...+55 °C (+14...+131 °F)
	Storage and transportation	-20...+70 °C (-4...+158 °F)
Max. altitude		2000 m
Relative humidity		5...95%; no condensation Tested according to IEC 60068-2-78

Table 11-2 Shock, Vibration, Noise Immunity

Characteristic	Rating
Shock	IEC 60068-2-27 (operating), 15 g/11 ms, half-sinusoid
Vibration	IEC 60068-2-6 (operating), 10 to 150 Hz, acceleration 2 g continuous (20 m/s ²); 10 cycles per axis
Noise Immunity	Electrostatic: 15 mA induced noise into any test lead without losing measurement accuracy at maximum interference to specimen current of 20:1 Electromagnetic: 500 µT, at 60 Hz in any direction

11.3 CE Conformity and Safety Standards

Table 11-3 CE Conformity, Safety Standards, EMC

CE Conformity	
The product adheres to the specifications of the guidelines of the Council of the European Community for meeting the requirements of the member states regarding the electromagnetic compatibility (EMC) Directive 2004/108/EC and the low-voltage Directive 2006/95/EC.	
EMC	
Emission	
Europe	EN 61326-1 Class A
International	IEC 61326-1 Class A
USA	FCC Subpart B of Part 15 Class A
Immunity	
Europe	EN 61326-1
International	IEC 61326-1
Certified Safety Standards	
Europe	EN 61010-1
International	IEC 61010-1
USA	UL 61010-1

11.4 Cleaning



Warning: Prior to cleaning disconnect the *CP TD1*.

To clean the *CP TD1*, use a cloth dampened with isopropanol alcohol or water.

11.5 Accessories

11.5.1 Cables and Clamps

The following accessories are delivered with the *CP TD1*:

Accessories
1 High-voltage cable, triaxial, 20 m with cable drum
2 Low-voltage cables, coaxial, 20 m on one cable drum
2 Cables (1 × red, 1 × blue) for connecting low-voltage cable drum with <i>CP TD1</i>
2 Different high-voltage clamps
2 Low-voltage clamps (1 × red, 1 × blue)
2 Different interface cables (0.5 m/3 m) for configurations with/without trolley
2 Booster cables (0.5 m/3 m)
1 Grounding cable
1 Transport case

11.5.2 Optional Accessories

TH 3631 Temperature and Humidity Meter

Use the optional device *TH 3631* to measure ambient temperature, the test object temperature and humidity. Once these values were measured, enter them into the respective entry fields of the **TanDelta** test card's Settings Page at "Compensations" (refer to 3.4 on page 30).



Characteristic	Rating
Temperature	
Range	-10...+60°C (+14...+140 F)
Resolution	0.1°C (0.18 F)
Accuracy	±0.4°C (±0.72 F)
Humidity	
Range	5...95% relative humidity
Resolution	0.1%
Accuracy	2.5%
Battery	9 V block cell or 9 V NiCd Accu
Weight	150 g (0.066 lbs)
Dimensions (w x h x d):	71 ×141× 27 mm (2.8 × 5.6 × 1.1")

WTF 0031-150/C External Temperature Sensor

The *WTF 0031-150/C* external sensor for measuring surface temperature is delivered with the *TH 3631* temperature and humidity meter.

Characteristic	Rating
Temperature range	-50...+150°C (-58...302 F)
Cable length	1 m

11.6 Ordering Information

For ordering information on the *CP TD1* and accessories, see the table below.

Equipment description	Article number
<i>CP TD1</i> TanDelta test set including software (TanDelta test card), accessories and trolley & <i>CPC 100</i> test system	VE000640
<i>CP TD1</i> TanDelta test set including software (TanDelta test card), accessories and trolley	VE000641
<i>CP TD1</i> TanDelta test set including software (Transformer package), accessories and trolley & <i>CPC 100</i> test system with accessories	VE000645
Cables and clamps (see 11.5.1 "Cables and Clamps" on page 125)	VEHZ0600
<i>CP CAL1</i> calibration set & calibration report	VEHZ0642
<i>TH 3631</i> with <i>WTF 0031-150/C</i>	VEHZ0644

12 Appendix

12.1 Parallel and Serial Equivalent Circuit Diagrams

The dielectric losses in insulation can be presented in parallel and serial diagrams. The real situation is much more complicated and always is a mixture of an assortment of both diagram types. A parallel can be recalculated into a serial one and vice versa by using the following formulas.

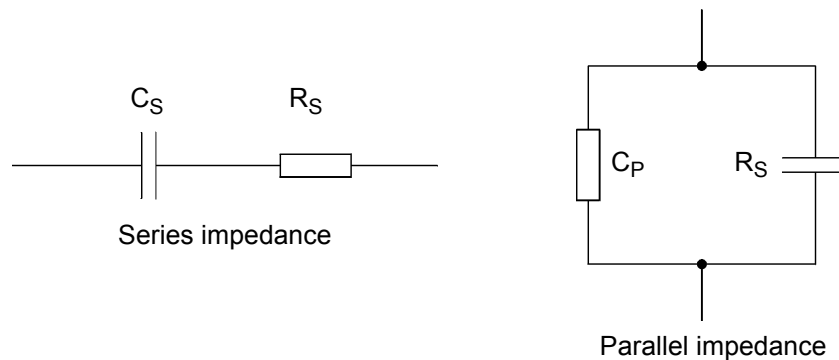

$$\tan \delta = \frac{1}{R_P \omega C_P}$$

$$C_P = \frac{C_S}{1 + \tan^2 \delta_S} = \frac{C_S}{1 + (R_S \omega C_S)^2}$$

$$R_P = R_S \left(1 + \frac{1}{\tan^2 \delta_S} \right) = R_S \left(1 + \frac{1}{(R_S \omega C_S)^2} \right)$$

Figure 12-1 Serial and parallel circuit diagram

12.2 Negative DF Measurements

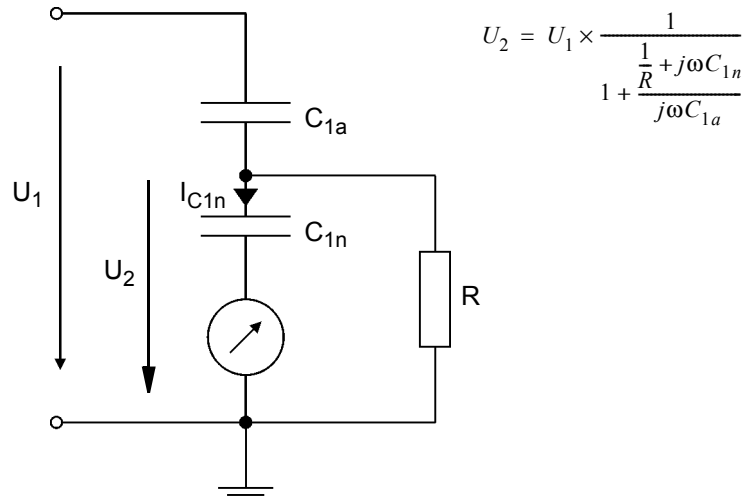
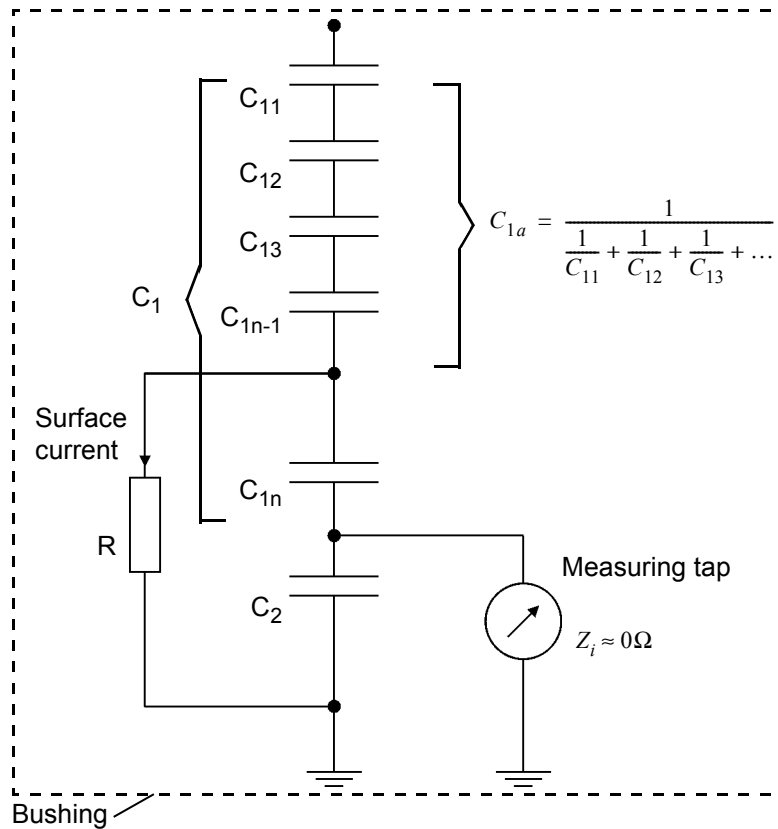

$$U_2 = U_1 \times \frac{1}{\left(1 + \frac{C_{1n}}{C_{1a}}\right) - j\left(\frac{1}{R\omega C_{1a}}\right)}$$

$$U_2 = U_1 \times \frac{\left(1 + \frac{C_{1n}}{C_{1a}}\right) + j\left(\frac{1}{R\omega C_{1a}}\right)}{\left(1 + \frac{C_{1n}}{C_{1a}}\right)^2 + \left(\frac{1}{R\omega C_{1a}}\right)^2}$$

$$\alpha = \arctan \frac{\frac{1}{R\omega C_{1a}}}{1 + \frac{C_{1n}}{C_{1a}}}$$

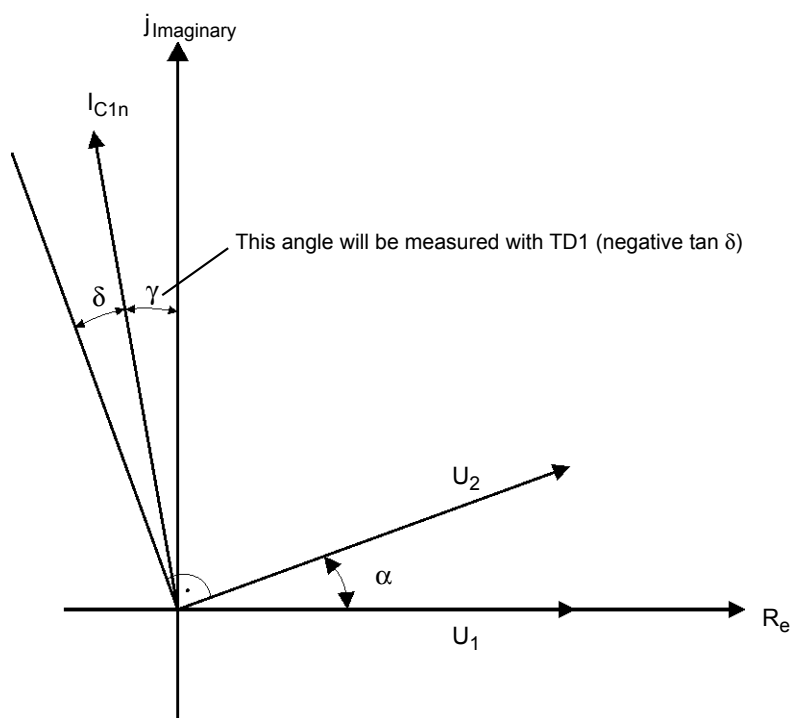

12.3 Two- and Three-Winding Transformer Tests (IEEE C57.12.90)

Method I Test without guard circuit ^a	Method II Test with guard circuit ^a
Two-winding transformers ^b	Two-winding transformers ^b
High to low and ground	High to low and ground
Low to high and ground	High to ground, guard on low
High and low to ground	Low to high and ground
—	Low to ground, guard on high
Three-winding transformers	Three-winding transformers
High to low, tertiary, and ground	High to low and ground, guard on tertiary
Low to high, tertiary, and ground	High to ground, guard on low and tertiary
Tertiary to high, low, and ground	Low to tertiary and ground, guard on high
High and low to tertiary and ground	Low to ground, guard on high and tertiary
High and tertiary to low and ground	Tertiary to high and ground, guard on low
Low and tertiary to high and ground	Tertiary to ground, guard on high and low
High, low, and tertiary to ground	High and low to tertiary and ground
	High and tertiary to low and ground
<p>Note 1: While the real significance that can be attached to the power factor of liquid-immersed transformers is still a matter of opinion, experience has shown that power factor is helpful in assessing the probable condition of the insulation when good judgement is used.</p> <p>Note 2: In interpreting the results of power-factor test values, the comparative values of tests taken at periodic intervals are useful in identifying potential problems rather than an absolute value of power factor.</p> <p>Note 3: A factory power-factor test will be of value for comparison with field power-factor measurements to assess the probable condition of the insulation. It has not been feasible to establish standard power-factor values of liquid-immersed transformers for the following reasons:</p> <ol style="list-style-type: none"> a) Experience has indicated that little or no relation exists between the power factor and the ability of the transformer to withstand the prescribed dielectric tests. b) Experience has shown that the variation in power factor with temperature is substantial and erratic so that no single correction curve will fit all cases. c) The various liquids and insulating materials used in transformers result in large variations in insulation power-factor values. 	

^{a)} In this table the term guard signifies one or more conducting elements arranged and connected to

an electrical instrument or measuring circuit to divert unwanted currents from the measuring means.

b) Permanently connected windings, such as in autotransformers or regulators, shall be considered as one winding.

12.4 Limits for Test Voltages for C2 Testing on Bushings

Manufacturer	Bushing Type or Class	Test Voltage
ABB	O+C	1000
ASEA	All GO types	500
BBC	CTF, CTKF	500
Canadian General Electric	U	1000
General Electric	LC, U	500
Haefely	All	500
Lapp	POC	1000
Micafil	WtxF	500
Micanite & Insulators	All	500
Ohio Brass	L	250
Ohio Brass	GK, LK	500
Passoni & Villa	All	500
Pennsylvania (Federal Pacific)	P	500
Westinghouse	S, OS	500

Source: Schurman, D.: Testing and maintenance of high-voltage bushings, Western Area Power administration, Golden (Colorado), 1999.

12.5 C2 Measurement on High-Voltage Bushings

With kind permission of: Pritpal Singh, ABB Inc., USA

12.5.1 Abstract

Measurement of C2 power factor and capacitance of condenser bushings has been a topic of much interest among the utility and other users for quite sometimes. This paper deals with the subject of C1 and C2 power factor and

capacitance in condenser bushings. It describes the constructional/design differences between C1 and C2 and discusses the factors that can influence these measurements.

12.5.2 Introduction

C2 power factor and capacitance measurement of condenser bushings has been a topic of much discussion for many years. Even though this measurement can be influenced by various external factors, more and more users are making C2 measurements to assess the quality of the bushing insulation. As per the IEEE bushing standards, bushings rated 115 kV and above are tested for C1 and C2 capacitance and power factor values. Both these capacitances are mainly dependant on paper insulation, which is strictly controlled by condenser design, therefore producing predictable test results. Bushings rated 69 kV and below on the other hand have an inherent C2 capacitance that is dependent upon on a few outer layers of paper with adhesive, and an oil gap. The C2 power factor and capacitance of these bushings can be affected by external stray factors. These factors among others may include contamination on porcelains, air and oil surrounding the bushing. This paper describes the constructional / design differences of C1 and C2 capacitance between bushings of different voltage classes/designs and discusses the factors that can influence these measurements.

12.5.3 Design/Construction of C1 and C2 Capacitance in Condenser Bushings

As per the IEEE Standards C57.19.00 and C57.19.01, condenser bushings rated 115 kV and above are provided with C1 (main) and C2 (tap) capacitances. The C1 capacitance is formed by the main oil/paper insulation between the central conductor and the C1 layer/foil, which is inserted during the condenser winding process. The C2 capacitance is formed by the tap insulation between the C1 and the C2 layers.

The C1 layer/foil is internally connected to the voltage tap stud whereas the C2 layer/foil is permanently connected to the grounded mounting flange.

Under normal operating condition, the C1 layer/foil is automatically grounded to the mounting flange with the help of the screw-in voltage tap cover that makes a connection between the tap stud and the mounting flange. The C2 insulation under normal operating condition is therefore shorted and not subjected to any voltage stress. When such a bushing is used in conjunction with a potential device, the voltage tap is connected to this device. Under this condition, the C1 and C2 capacitances are in series and perform like a voltage or a potential divider. The voltage developed across the C2 capacitance is modified by the potential device and is used for operation of relays, and other instruments. Also,

the voltage tap can be used for measuring the power factor and capacitance of C1 and C2 insulation of the bushing. In addition, this tap can be used for monitoring the partial discharge during factory tests and insulation leakage current (including partial discharge) during field service operation. See Figure 12-2 for condenser design and voltage tap details.

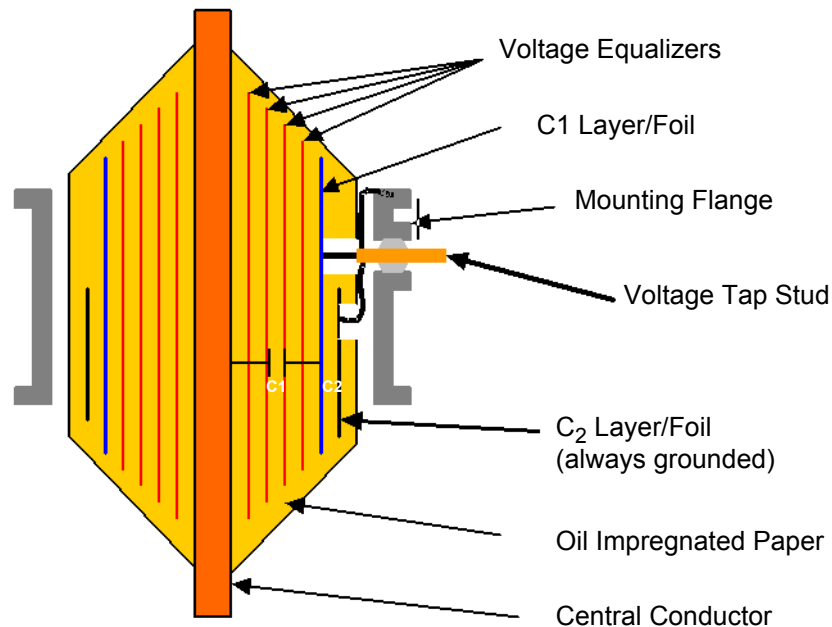

Figure 12-2 Design/construction details of a typical condenser bushing rated 115 kV and above

Condenser bushings rated 69 kV and below as per the IEEE Standards are provided with C1 capacitance, which is the main capacitance. This capacitance is formed by the oil/paper insulation between the central conductor and the C1 layer/foil, which is inserted during the condenser winding process. The C1 layer/foil is internally connected to the test tap.

These bushings have an inherent C2 capacitance, which is formed by the insulation between the C1 layer and the mounting flange. This insulation consists of a few layers of paper with adhesive, an oil gap between the condenser core and the mounting flange, and the tap insulator. Under normal operating condition, the C1 layer/foil is automatically grounded to the mounting flange with the help of the screw-in test tap cover that makes a connection between the test tap spring and the flange. The C2 insulation under normal operating condition is therefore shorted and not subjected to any voltage stress. The test tap is used for measuring the power factor and capacitance of C1 and

C2 insulation of the bushing. In addition, this tap is sometimes used for monitoring the partial discharge during factory tests and insulation leakage current (including partial discharge) during field service operation. See Figure 12-3 for condenser design and test tap details.

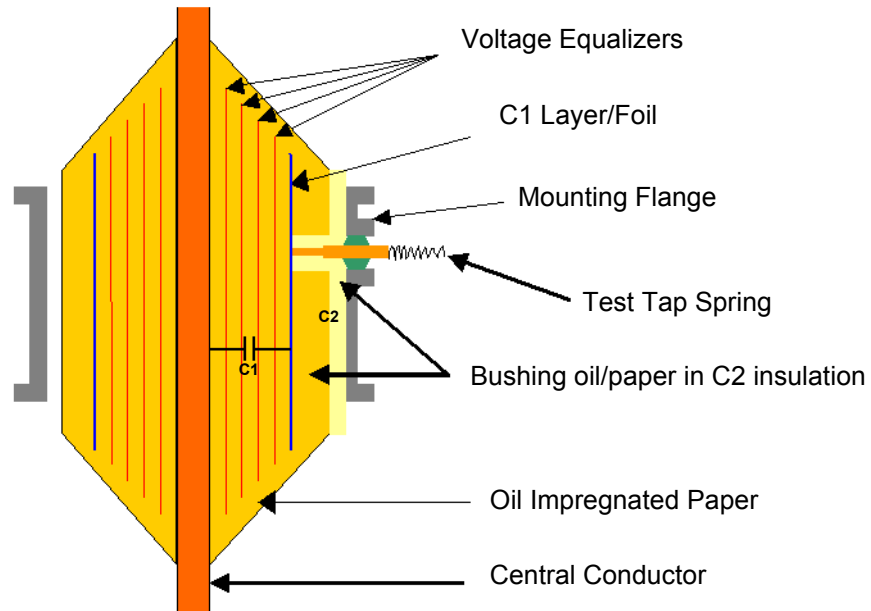

Figure 12-3 Design/construction details of a typical condenser bushing rated 69 kV and below

12.5.4 Factors Affecting C1, C2 Capacitance and Power Factor Measurements

As mentioned earlier, the C1 and C2 capacitance of condenser bushings rated 115 kV and above are strictly controlled by design and are mainly dependent upon oil impregnated, paper insulation. Therefore, the power factor and capacitance test values under normal circumstances, are not affected too much by external factors. However, under conditions of contamination and high humidity, these measurements may be significantly affected. In addition, capacitively coupled resistive paths to ground may affect these measurements. These may include supporting structures, wooden crates that are moist/wet, resistance between bushing mounting flange and the transformer tank, stray effect from other objects, and external connections during testing. Although, the

IEEE Standard C57.19.01 specifies a limit 0.5% for C1 power factor for oil impregnated paper insulated bushings, Type O Plus C, AB, and T condenser bushings C1 power factor values are well below this limit.

Condenser bushings rated 69 kV and below as mentioned earlier, have the main C1 capacitance, which is strictly controlled by design. Like the bushings rated 115 kV and above, the C1 power factor and capacitance test values of these bushings are not affected too much by external factors under normal circumstances. However, under conditions of contamination and high humidity, these measurements may be significantly affected. Also, these measurements may be affected by supporting structure, wooden crates that are moist/wet, resistance between bushing mounting flange and the transformer tank, stray effect from other objects, and external connections during testing. These bushings have an inherent C2 capacitance, which is dependent upon a few outer layers of paper with adhesive, an oil gap between the flange and the condenser core, and the tap insulator. Variations in adhesive in the outer paper layers and other factors can result in PF variations in bushings of the same style number. In addition, the close proximity of the C1 layer (see figure 12-3) with the mounting flange results in greater fringing effect between the two parts. As a result of this, the porcelains, oil, and air surrounding the bushing can have some affect on the C2 power factor test values. In particular, high current Type T condenser bushings with a short mounting flange and a long internal C1 layer/foil tend to exhibit higher power factors because of greater coupling effect

between the C1 layer/foil and the surrounding materials, as shown by patterned areas in Figure 12-4. Depending upon the design, the C2 power factor of these bushings can range from 0.1% to 2%.

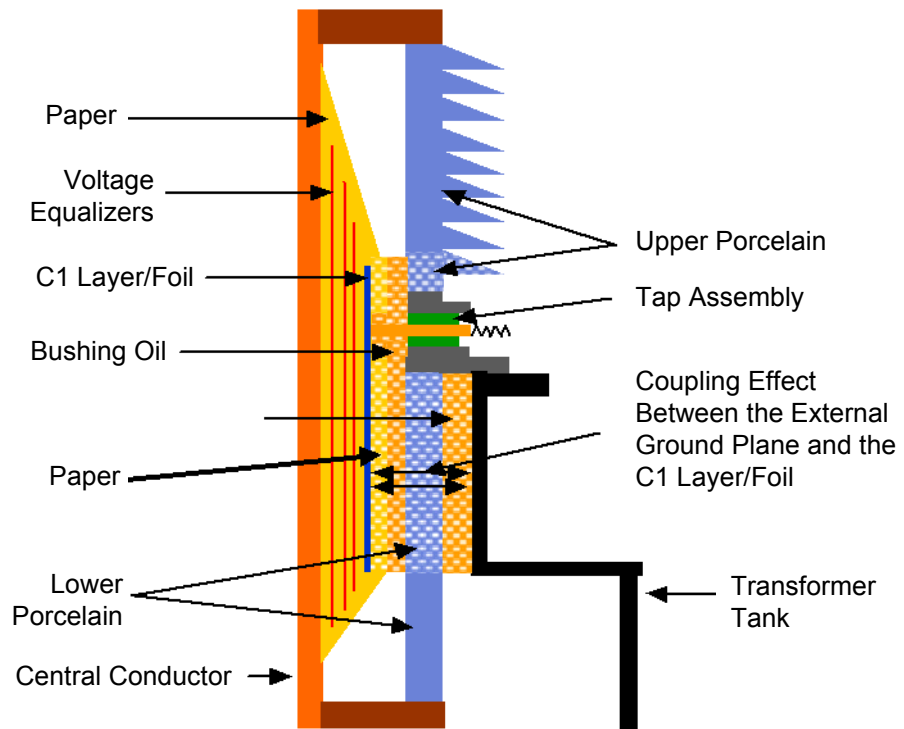

Figure 12-4 Design/construction details of a typical high current type T bushing and the influence of surrounding materials/objects

One of the factors that can significantly influence the C2 capacitance in bushings with long internal C1 layer/foil and a short mounting flange is the external ground plane. The following table shows the effect of proximity and type of ground plane on power factor and capacitance of two different types of condenser bushings. Type AB, which is similar to an O Plus C bushing with a metallic mounting flange and a long external ground sleeve. Type T bushing with short mounting flange and a long internal C1 layer/foil as shown in figure 12-4.

TYPE / STYLE ->	AB / B035200AA	AB / B035200AA	T / 025V1000VY	T / 025V1000VY
	C1 / C2 PF %	C1 / C2 CAP pF	C1 / C2 PF %	C1 / C2 CAP pF
NP Values	0.29 / 0.11*	508 / 494*	0.28 / 0.64**	1112 / 306**
In air. No grd. plane	0.27 / 0.10	514 / 492	0.29 / 0.58	1124 / 278 (1 PU)
In air. Flat vertical grd. plane 3 in away from the lower porcelain	0.27 / 0.10	511 / 492	0.29 / 0.56	1119 / 292 (1.05 PU)
In air. Cylindrical grd. plane which is:	xx	xx	xx	xx
6 in away from the lower porcelain.	xx	xx	0.27 / 0.55	1108 / 303 (1.09PU)
1 in away from the lower porcelain.	0.26 / 0.10	505 / 495	0.27 / 0.60	1101 / 431 (1.55PU)

* C2 value is normally checked in air. C1 value is normally checked with lower end immersed in oil.

** C1 and C2 values are normally checked with lower end immersed in oil.

As can be seen from the above table, the C1 and C2 capacitance values of Type AB bushing have basically very little effect from the type or proximity of the ground plane within the practical range of clearances. Similarly the C1 capacitance of Type T bushings has minimal effect from the type or proximity of the ground plane. The C2 capacitance of Type T bushing on the other hand increased by 55% (from 278 pF to 431) when the bushing was tested with a cylindrical ground plane surrounding the lower porcelain with an air gap of about 1 inch. This is because of greater coupling effect between the C1 layer/foil and the external ground plane. The above bushings were tested in a clean and dry environment and therefore the power factor values exhibit very little change if any. If the lower end of the bushing was immersed in oil, the increase in capacitance would be higher as the oil has a higher dielectric constant.

Another observable fact is the small difference of C2 PF and CAP test values of Type T bushing between nameplate (with lower end immersed in oil) and those taken with the bushing in air and no external ground plane. The test values with the lower end in air are lower by about 10%. This could be due to the fact that air has zero power factor and a lower dielectric constant compared to oil. Since, Type T bushings have a greater coupling effect between the C1 plate and the medium surrounding the lower porcelain, the C2 values are somewhat lower when the test is made in air.

Due to design and construction, the C2 power factor of condenser bushings rated 69 kV and below may therefore exceed the C1 power factor limit of 0.5 % specified in the IEEE Standard. The IEEE Standard does not specify any limit for C2 power factor. The C1 power factor on the other hand is well below the 0.5 % limit specified by the IEEE standard.

For bushings rated 69 kV and below, IEEE Standard only requires stamping of C1 power factor and capacitance on the nameplate. As a result of frequent requests from customers, ABB Inc. Alamo, TN started stamping the C2 power factor and capacitance test values on bushing nameplates since December of 2002.

With this addition, the nameplates of all AB, O Plus C, and T condenser bushings are now stamped with factory test values of C1 and C2 power factor and capacitance. We complied with the industry's need so that users can better assess the condition of the bushing insulation. Because of reasons mentioned within this paper, users may see a greater variation in C2 power factor and capacitance values in different bushings of the same design.

It is important to compare the initial test values before installation with the nameplate values. To verify nameplate values (especially for Type T bushings), the measurements should be made with the bushing mounted on a metallic test tank/stand with the lower end porcelain immersed in dry good quality oil. There should be sufficient clearance (at least 16 - 20 inch) from the bushing lower porcelain/terminal to the grounded tank. For C2 measurement, the center conductor should be guarded and test tap voltage not exceeding 1 kV. For detailed test set up and other information, refer to test equipment manufacturer's instructions.

Once the bushing has been installed in the apparatus, it should be retested to establish a benchmark value. It is important to compare the subsequent field test values with the initial benchmark value after installation. Any significant deviation (10% change in capacitance or doubling of power factor) from the benchmark value would be a cause for concern and should be investigated. Test values with lower end in air may vary from those with lower end immersed in oil.

12.5.5 Conclusions

Because of the inherent design of C2 capacitance and design/constructional differences in bushings rated 69 kV and below, the C2 power factor and capacitance can be affected by external factors. These factors may include external contamination, humidity, and stray effect and proximity of other objects. As a result of this, the field installed C2 power factor and capacitance test values can vary from the nameplate values. Test values with lower end in air may vary from those with bushing mounted on the transformer with lower end immersed in oil. Sometimes, variations may be noticed between bushings of the same

design. The initial test values before installation should be compared with the factory nameplate values. While checking the power factor and capacitance values of these bushings, it is important to compare the field test values with the initial benchmark value after installation. Any significant deviation from the benchmark value would be a cause for concern and should be investigated.

Additional information on bushing maintenance can be found in ABB bushing instruction leaflets IL 44-663, 665, and 666 available on our web site at <http://alamo.abbus.com>.

12.5.6 Biography

Pritpal Singh is a Fellow Engineer with ABB Inc. in Alamo, TN and is engaged in business/product development activity. In the past 41 years, he has been involved in the design, development, and testing of transformers and bushings. He has held different technical and management positions in BHEL (India), General Electric (Pittsfield, MA), Westinghouse (Alamo, TN), and now with ABB Inc. (Alamo, TN). He has been an active member of the IEEE Transformer Committee for the past 20 years and was the Chair of the WG for the revision of IEEE Std. C57.19.01 - 2000. Presently, he is the Secretary of Bushing Subcommittee. He is a native of India and graduated in 1962 with a Bachelor of Science degree in Electrical Engineering from Aligarh University.

12.5.7 References

1. IEEE Standard C57.19.00 - 1991
2. IEEE Standard C57.19.01 - 2000
3. Doble Manual for Testing of Electrical Insulations by the Dielectric Loss and Power factor.
4. A.L. Rickely and R.E. Clark: "Application and Significance of Ungrounded Specimen Tests", Minutes of the Doble Clients Conference 27AC60, Page 3-201.
5. D.J. Kopaczynski and S.J. Manifase: "The Doble Tap - Insulation Test For Bushings (A Review)", Minutes of the Doble Clients Conference 57A1C90, Page 4-3.1.
6. Raka Levi and Stan Manifase: "Further Studies of Anomalous Phenomena In Dielectric-Loss Measurement - Transformer Bushings Model", IEEE Transaction on Power Delivery, Vol. 10, No. 2, April 1995.
7. IEEE Standard C57.19.01 - 2000: "Performance Characteristics and Dimensions For Outdoor Apparatus Bushings".

12.6 DF Limits of RBP Bushings (Micafil AG)

Limits are reached in approximately 25 years. Not valid for humid insulators.

a) Limits of the dissipation factor at 20°C:

U rated [kV]	DF (%)
36	2.5
73	2.3
123	2.0
170	1.8
245	1.5
300	1.3
302	1.15
420	1.0

b) Limits of the capacitance change (Delta C) at 20°C

U rated [kV]	Delta C (%)
36	25
73	23
123	20
170	18
245	15
300	13
302	12
420	10

Source: Widmann, Karl: Zustandserfassung und Bewertung von Durchführungen im Betrieb, MICAFIL Symposium Stuttgart, 1999

12.7 DF Limits of Bushings (B)

Manufacturer	Bushing Type or Class	Initial P.F. for new bushings, at	Dangerous P.F. value at 20 x C (%)
General Electric	A	6.0	8.0
	B	10.0	12.0
	F	1.5	2.0
	L	3	4.0
	LC	2.5	3.5
	OF	2.6	6.0
	S	3.5	6.0
	U	1.0	1.5
Lapp bushings	POC	0.5	
	PRC	0.7 - 1.2	
Ohio Brass manufactured prior to 1926 and after 1938	ODOF	1 - 10	Initial P.F. = 22
	G		
	L		
Ohio Brass manufactured 1926 to 1938, inclusive	ODOF	2 - 4	Initial P.F. = 16
	G		
	L		
Ohio Brass	Class GK type C	0.4 - 0.6	
	Class LK type A	0.6 - 0.7	
Pennsylvania Transformer	P	0.5	1.0
	PA		
	PB		
Westinghouse	D		6.0
	O		1.4
	OCB & Inst. Trans. 69kV and below		3.5
	OCB & Inst. Trans. 92kV - 138kV		2.8
	Power & Dist. Trans. OCB 161kV - 288kV		2.0

Source: US Bureau of Reclamation: "Testing and Maintenance of High Voltage Bushings", Facility instructions, standards and techniques -vol 3-2, Denver, 1991

12.8 DF Limits of Bushings (C)

Manufacturer: Description	Bushing Type or Class	Power Factor Limits (% at 20°C)	
		Typical	Doubtful or questionable
ASEA Brown Boveri (ABB)	O+C	0.5	Double name- plate
	T	0.5	
Note: 1. Contact manufacturer if capacitance increases to 110% of original installed value 2. Reference ABB instruction leaflet 44-666E dated July 1, 1990.			
ASEA Less than 800kV 800kV	GOA 250	0.5	0.7
	GOB	0.5	0.7
	GOBK	0.5	0.7
	GOC	0.4	0.6
	GOE	0.45	0.65
	GOE	0.4	0.6
	GOEK	0.4	0.6
	GOEL	0.4	0.6
	GOF	0.45	0.65
	GOFL	0.4	0.6
	GOG	0.45	0.65
	GOH	0.25	0.45
	GOM	0.45	0.65
GOA other	0.45	0.65	
Note: 1. Up to 3% change from nameplate capacitance is considered acceptable 2. Remove from service if the difference between nameplate and measured C ₁ percent power factor exceeds 75% 3. Reference ABB Components bulletin #2750 515E-56, dated 1990.			
Bushing Company (Reyrolle Limited) Includes: Micanite & Insulators (M&I) English Electric Ferranti	OTA	0.35	0.6
Note: Reference Bushing Company fax dated 9/1/1993			

Manufacturer: Description	Bushing Type or Class	Power Factor Limits (% at 20°C)	
		Typical	Doubtful or questionable
General Electric:			
Through Porcelain ¹	A	3.0	5.0
High Current, Solid Porcelain ²	A	1.0	2.0
Flexible Cable, Compound Filled ¹	B	5.0	12.0
Oil-Filled Upper Portion, Sealed	D	1.0	2.0
Oil-Filled, Sealed	F	0.7	1.5
Oil-Filled Upper Portion, Sealed	L	1.5	3.0
Oil-Filled Upper Portion, Sealed	LC	1.5	3.0
Oil-Filled Expansion Chamber	OF	0.8	2.0
Forms C & CG, Rigid Core, Compound Filled ¹	S	1.5	6.0
Oil-Filled, Sealed	U	0.5	1.0
Oil-Filled, Sealed	T	0.5	1.0
Note: 1. Forms S, Type F, DF, and EF (flexible cable) redesigned as types B, BD, and BE, respectively, no form letter (through porcelain redesigned as type A). 2. Modern high current oil-filled solid porcelain design.			
Haefeley Trench:			
Under 1400kV BIL	COTA	0.3	Double Name-plate
1400kV BIL and above	COTA	0.35	
Note: 1. C ₁ capacitance is doubtful if 10% over nameplate. 2. C ₁ capacitance is doubtful if 5% over first measurement in field after installation. 3. C ₂ capacitance may vary by 20%. Reference Haefeley fax dated April 5, 1994. 4. Some bushings, 115kV and above, which have potential taps, have C ₁ nameplate capacitance based on factory tests made on the test tap. The test tap is then buried and unavailable to the user. The user instead tests the bushing using the potential tap where the capacitance appears to be high compared to the nameplate values. The capacitance obtained in the field must be modified as follows: $C_1 = (C_1 (\text{Haefeley}) \times (C_2 (\text{Haefeley}))) / (C_2 (\text{Haefeley}) - (C_1 (\text{Haefeley})))$, where (C ₁ (Haefeley)) and (C ₂ (Haefeley)) are the nameplate capacitances. 5. Reference Haefeley fax dated April 3, 1995.			

Manufacturer: Description	Bushing Type or Class	Power Factor Limits (% at 20°C)	
		Typical	Doubtful or questionable
Lapp:			
Paper Oil Condenser type; Totally Enclosed, 23-69kV	POC & PA	0.5	1.5
Paper Resin Condenser Core	PRC & PRC-A	0.8	1.5
Paper Epoxy hard core type; No Lower Porcelain	ERC	0.8	1.5

Source: Schurman, D.: "Testing and maintenance of high voltage bushings", Western Area Power administration, Golden (Colorado), 1999

12.9 Transformer Diagnosis

Practical experience using simple methods like winding resistance measurement, dynamic tap changer testing, ratio, leakage reactance, capacitance and dissipation factor measurement.

By Michael Krüger, OMICRON electronics GmbH Austria

12.9.1 Introduction

Due to ever-increasing pressure to reduce costs, the power industry is forced to keep old power facilities in operation as long as possible. In most European countries, about one third of the transformers are older than 30 years. Transformers, which are older than 50 years can still be found in service [1].

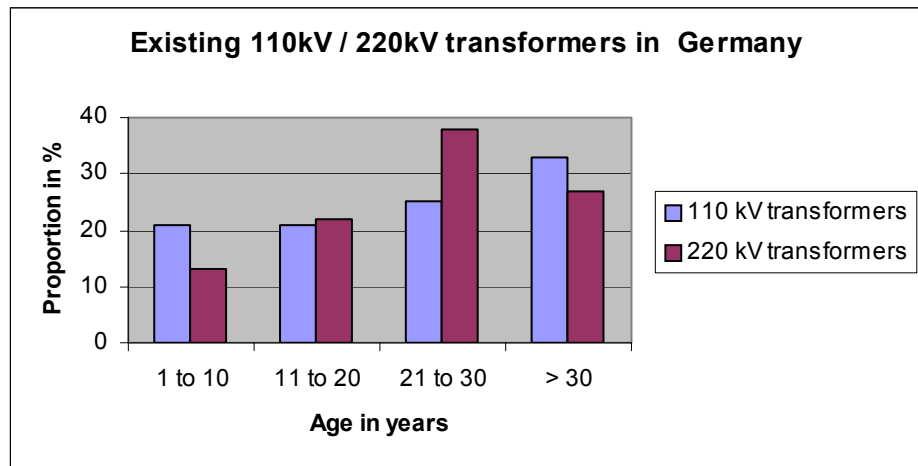

Figure 12-5 110/220 kV transformers in Germany

With the advancing age of transformers, a regular check of the operating conditions becomes more and more important. The Dissolved Gas Analysis is a proven and meaningful method such that if increased proportions of hydrocarbon gases are found in the oil, the fault must be located as soon as possible. This way, important preventative maintenance can be performed in time to avoid an unexpected total failure (Figure 12-6) [2].



Figure 12-6 Transformer fault due to a defective bushing

The most frequent sources of failure are the tap changers, bushings, the paper-oil insulation and the accessory equipment (Figure 12-7).

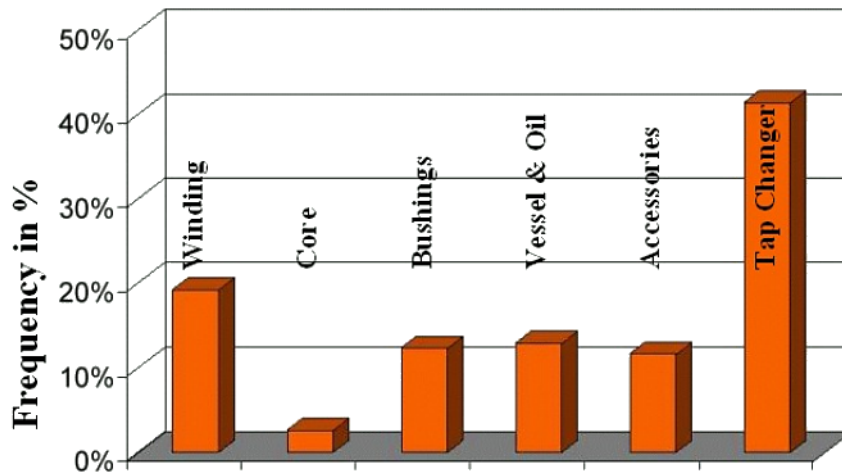

Figure 12-7 Sources of transformer faults

12.9.2 Methods of Analysis

One of the most important and proven methods is **Dissolved Gas Analysis (DGA)**. The hydrocarbon gases dissolved in the oil allow conclusions to be made about the condition of the transformer and specific faults by investigating changes of the gas composition [4], [5], [6], [7]. The measured quantities of the gases (expressed as a quotient) as they are shown in the last line of the table (Table 12-1) suggest high temperatures.

Table 12-1 Dissolved Gas Analysis

	Type of fault	$\frac{C_2H_2}{C_2H_4}$	$\frac{CH_4}{H_2}$	$\frac{C_2H_4}{C_2H_6}$
PD	Partial discharge	< 0.01	< 0.1	< 0.2
D1	Discharge with low energy	> 1	0.1 - 0.5	> 1
D2	Discharge with high energy	0.6 - 2.5	0.1 - 1	> 2
T1	Thermal fault T < 300°C	< 0.01	> 1	< 1
T2	Thermal fault T < 700°C	< 0.1	> 1	1 - 4
T3	Thermal fault T > 700°C	< 0.2	> 1	> 4

One possible reason for the observation of high temperatures could be the existence of high contact resistances at the tap selector. However, there are many other possible reasons for increased gas values in the oil. An example might be decomposed oil leaking from the diverter switch into the transformer oil through a defective sealing between the diverter switch vessel and the transformer tank. Exceptionally high current densities causing high temperatures can also occur as a result of partial breaks in conductors connected in parallel. Further interesting information about this can be found in [4], [5], [6] and [7].

12.9.3 Fault Localization

In order to find out the reason for high gas values, further tests have to be performed for the transformer. Common test methods are:

- Winding resistance measurement
- On-Load Tap Changer (OLTC) test
- Turns ratio measurement
- Excitation current measurement
- Measurement of leakage reactance
- Capacitance and Dissipation factor measurement



Figure 12-8 A multi-functional transformer test and diagnosis system

In this paper, all tests were performed with a new self-contained test system. The device comprises a Digital Signal Processor (DSP) which generates sinusoidal signals in a frequency range of 15 to 400 Hz which is fed into a switched-mode power amplifier. A transformer at the output matches the internal amplifier impedance with the test object impedance [8]. By utilizing test

frequencies different from the line frequency and their harmonics, together with measurements using selective filtering techniques, the test equipment can be operated on-site, even in substations with high electromagnetic disturbances.

12.9.4 Winding Resistance Measurement and On-Load Tap Changer Test

Winding resistances are tested in the field to check for loose connections, broken strands and high contact resistance in tap changers. Additionally, the dynamic resistance measurement enables an analysis of the transient switching operation of the diverter switch.

For a better understanding of the resistance measurements, it is necessary to understand the method of operation of the tap changer (Figure 12-9).

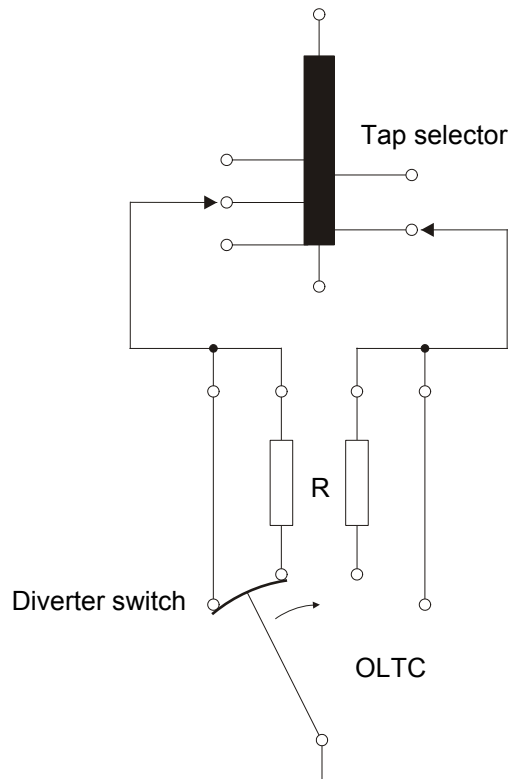

Figure 12-9 Equivalent circuit diagram of On-Load Tap Changer (OLTC)

In most cases, the tap changer consists of two units. The first unit is the tap selector, which is directly located inside the transformer tank and switches to the next higher or lower tap without carrying current. The second unit is the diverter switch, which switches without any interruption from one tap to the next while carrying load current. The commutation resistances R limit the short circuit current between the taps which could otherwise become very high due to the interruption-free switching of the contacts. The switching process between two taps takes approximately 40 - 80 ms.

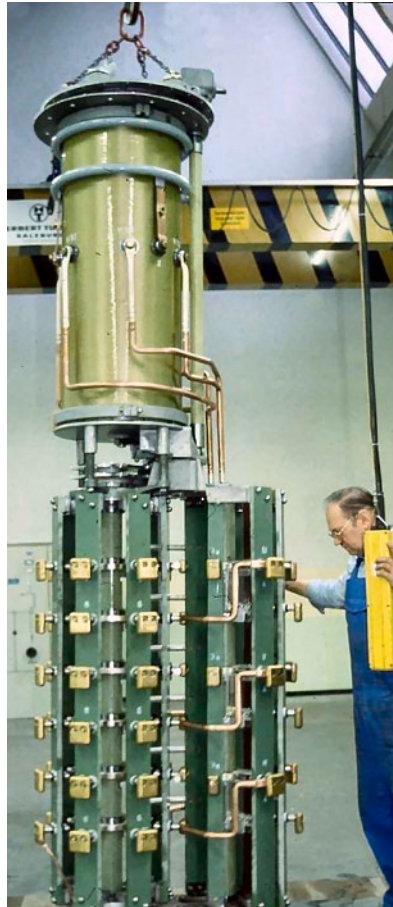

Figure 12-10 Tap changer

Figure 12-10 shows a tap changer with the tap selector (lower part) and the diverter switch (upper part). In Figure 12-11, a transformer with an attached tap changer is shown. In both pictures the separate oil tank of the diverter switch is clearly visible.

Figure 12-12 shows a diverter switch of a 40 MVA transformer for 110 kV. The switches shown are positioned near the star-point of the transformer's high-voltage windings.

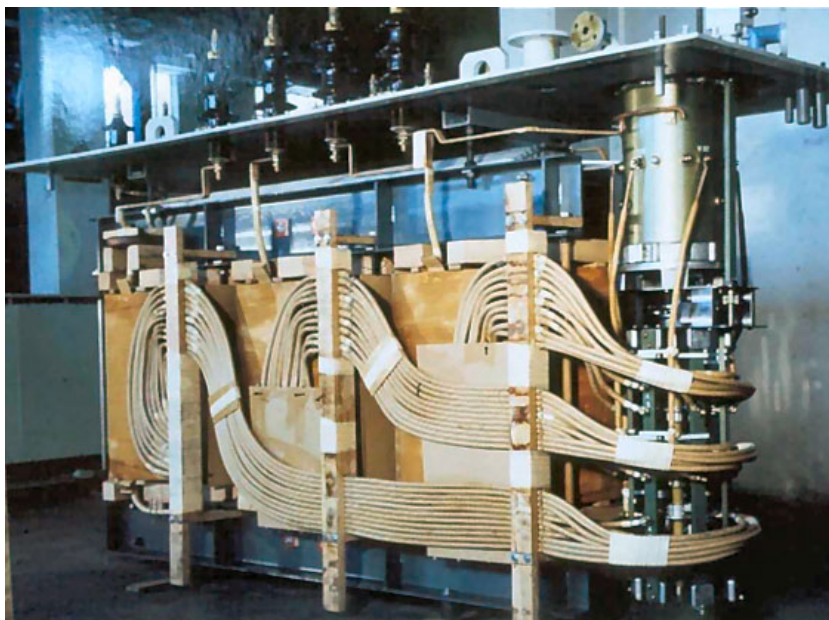

Figure 12-11 Transformer with tap changer

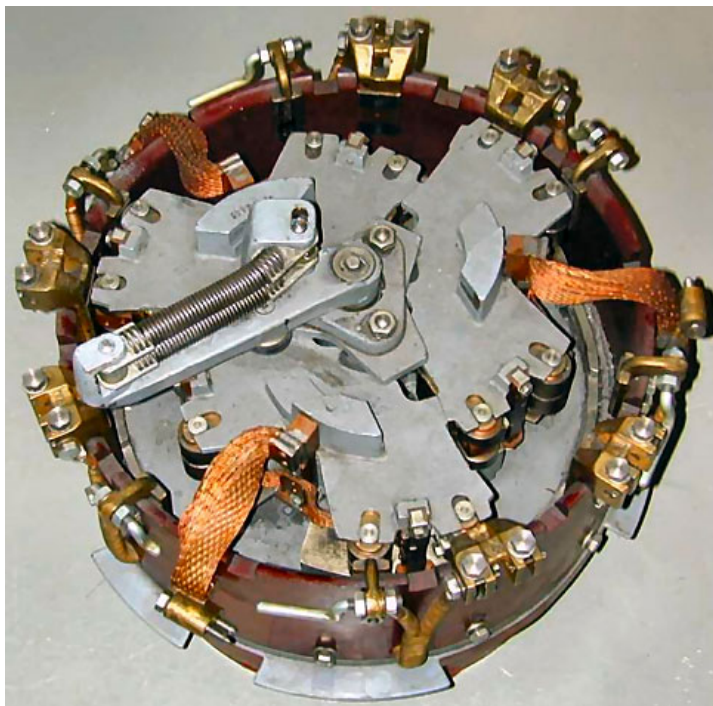

Figure 12-12 Diverter switch for 110 kV/40 MVA

12.9.5 Four-Wire Connection for Transformer Winding Resistance Measurement

Since the winding resistances are very small, the test set is connected in 4-wire configuration. It has to be observed that the contact resistances of the connection clamps do not falsify the measuring result (Figure 12-13).

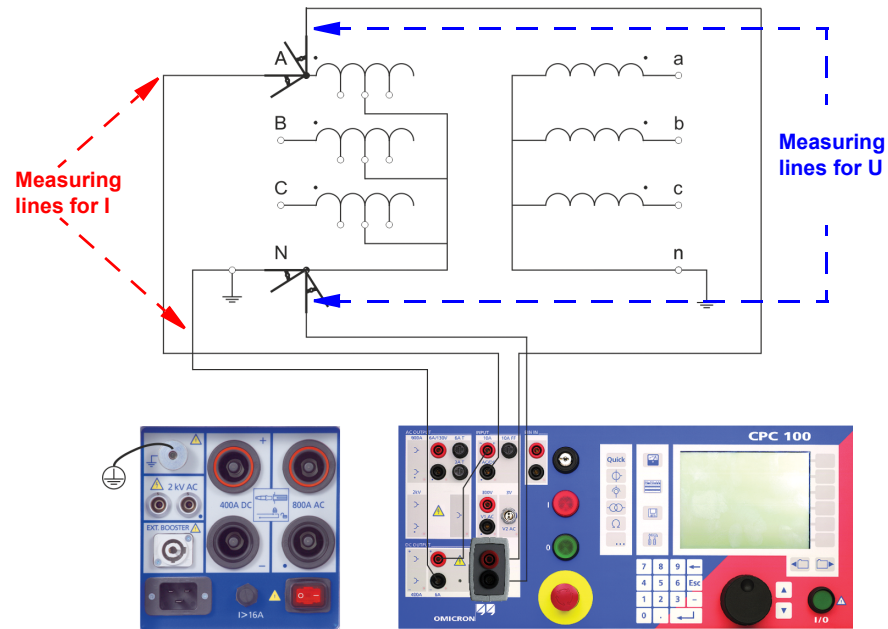

Figure 12-13 Four-wire resistance measurement

A constant current source is used to feed a direct current into the winding. The test current should be at least 1% of the rated current to bring the core into saturation. On the other hand it should not exceed 15% of the rated current to avoid temperature rise during measurement. A relatively high no-load voltage enables a quick saturation of the core and a final value with only minor fluctuations is reached. Therefore, in most cases the charging time per tap is distinctly less than 30 seconds. By pressing one button on the test system, all values are logged and a test report is automatically generated (Figure 12-14). The resistance values are automatically corrected to the reference temperature by automatic calculation utilizing the following formula:

$$R_x = R_m \times \frac{T_x + 235}{T_m + 235}$$

x = reference temperature
m = temperature at measurement

Time	R meas.	Dev.	R ref.	Ripple	Slope	IDC	VDC
42.000 s	649.7 mΩ	-0.17 %	664.9 mΩ	90.45 %	-8.024 mA/s	4.9203 A	3.1965 V
29.000 s	633.4 mΩ	0.10 %	648.3 mΩ	1.01 %	-173.3 mA/s	4.9215 A	3.1175 V
31.000 s	622.6 mΩ	-0.01 %	637.2 mΩ	0.92 %	-170.5 mA/s	4.9215 A	3.0641 V
31.000 s	613.2 mΩ	-0.03 %	627.6 mΩ	0.92 %	-151.6 mA/s	4.9215 A	3.0177 V
28.000 s	614.6 mΩ	-0.07 %	629.0 mΩ	0.86 %	-143.5 mA/s	4.9203 A	3.0238 V
33.000 s	610.9 mΩ	0.04 %	625.2 mΩ	0.87 %	-129.5 mA/s	4.9191 A	3.0049 V
36.000 s	607.0 mΩ	-0.01 %	621.2 mΩ	0.88 %	-123.2 mA/s	4.9179 A	2.9849 V
33.000 s	597.6 mΩ	0.01 %	611.7 mΩ	0.80 %	-113.1 mA/s	4.9179 A	2.9391 V
47.000 s	594.0 mΩ	0.14 %	607.9 mΩ	0.81 %	-106.1 mA/s	4.9179 A	2.9210 V
32.000 s	537.0 mΩ	-0.05 %	549.7 mΩ	0.74 %	-92.74 mA/s	4.9227 A	2.6436 V
34.000 s	569.3 mΩ	-0.03 %	582.6 mΩ	0.86 %	-111.7 mA/s	4.9191 A	2.8002 V
34.000 s	560.7 mΩ	0.06 %	573.9 mΩ	0.82 %	-84.09 mA/s	4.9179 A	2.7573 V
34.000 s	568.8 mΩ	-0.02 %	582.2 mΩ	0.80 %	-85.78 mA/s	4.9155 A	2.7962 V
35.000 s	568.9 mΩ	-0.03 %	582.3 mΩ	0.76 %	-82.80 mA/s	4.9143 A	2.7958 V
42.000 s	555.9 mΩ	0.08 %	568.9 mΩ	0.73 %	-81.17 mA/s	4.9143 A	2.7317 V
51.000 s	557.4 mΩ	0.28 %	570.6 mΩ	0.76 %	-68.81 mA/s	4.9143 A	2.7394 V
46.000 s	554.2 mΩ	0.10 %	567.3 mΩ	0.75 %	-79.97 mA/s	4.9131 A	2.7230 V
51.000 s	548.9 mΩ	0.05 %	561.8 mΩ	0.74 %	-70.01 mA/s	4.9131 A	2.6969 V
40.000 s	526.6 mΩ	-0.03 %	538.9 mΩ	0.78 %	-70.50 mA/s	4.9143 A	2.5877 V

Figure 12-14 Automatically generated test report

Even comprehensive measurements can be performed very efficiently within a short time. For example, if all resistances of the taps 1 - 19 upwards and the taps 19 - 1 downwards for all three phases are measured, this corresponds to a total of 114 resistance measurements. In this particular example, the testing time was found to be less than 90 minutes for all measurements.

12.9.6 Safety Aspects

Feeding currents of several amps through a coil rated at hundreds of Henries causes a high magnetic energy to be stored in the coil inductance. If the measuring circuit was interrupted without discharging this energy, very high voltages would be induced which would be very dangerous for the operator and the test system. An automatic discharge of the coil inductance after measurement is automatically carried out as it is essential for safe operation, though while switching from one tap to another, a discharge cycle is not necessary and this saves a lot of time.

12.9.7 Delta-Connected Windings

For delta-connected windings, R_{12} , R_{23} and R_{31} cannot be measured directly but calculated from the measured R_a , R_b and R_c values.

$$R_a = R_1 + R_2$$

$$R_b = R_2 + R_3$$

$$R_c = R_3 + R_1$$

Y connection without Neutral:

$$R_c - R_b + R_a = 2 R_1 \Rightarrow R_1 = (R_c + R_a - R_b) / 2$$

$$R_a - R_c + R_b = 2 R_2 \Rightarrow R_2 = (R_a + R_b - R_c) / 2$$

$$R_b - R_a + R_c = 2 R_3 \Rightarrow R_3 = (R_b + R_c - R_a) / 2$$

Closed delta winding

$$R_{12} = R_1 + R_2 + (R_1 \times R_2) / R_3$$

$$R_{23} = R_2 + R_3 + (R_2 \times R_3) / R_1$$

$$R_{31} = R_3 + R_1 + (R_3 \times R_1) / R_2$$

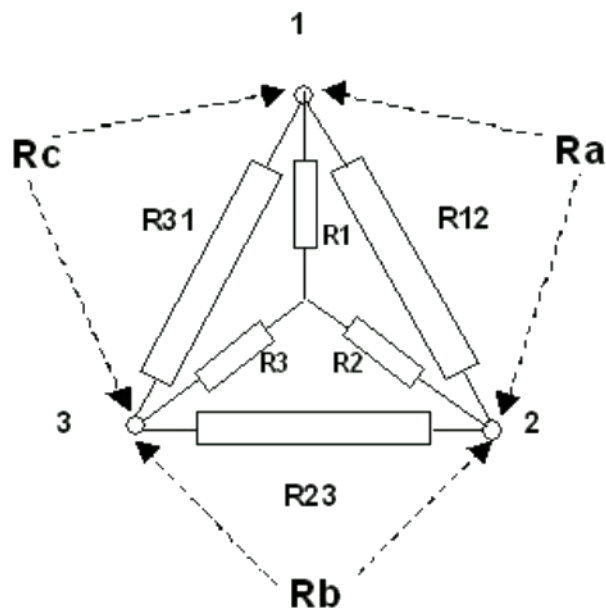

Figure 12-15 Delta-connected windings

12.9.8 Winding Resistance Measurement of a 100 MVA Transformer

The 220 kV/110 kV – 100 MVA transformer under test manufactured in 1995 was found to have conspicuously high quantities of gas in the oil, from which the conclusion was drawn of inner overheating. The measurement results taken with the test system (Figure 12-16) show a very good match with the values measured by the manufacturer for the mid-position (denoted as tap 10) of the tap selector in all phases, where direct connection to the main winding occurs.

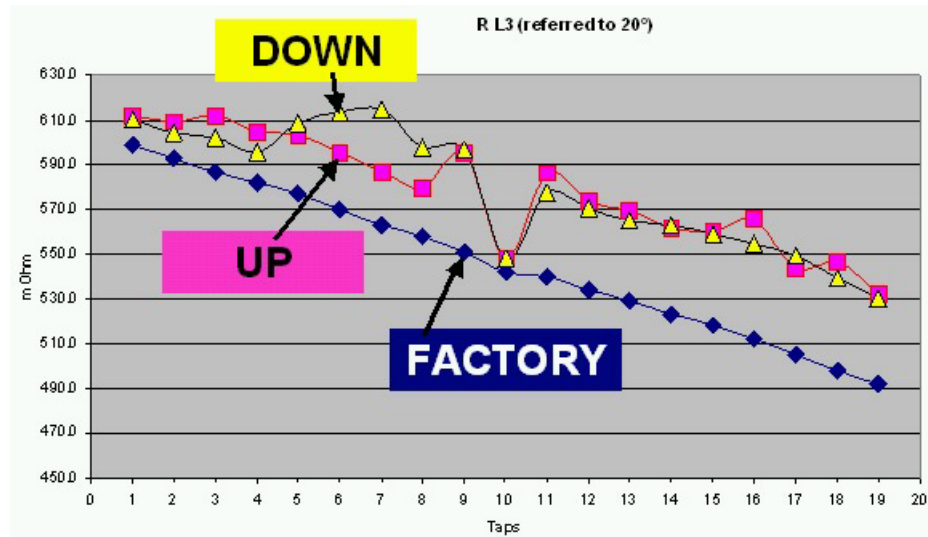

Figure 12-16 Winding resistance measurement H1-H0

In the measurements taken with the test system, the different winding temperatures were considered and all other taps showed a significant increase compared to the original measured values. The differences are more than 10% or, in absolute values, up to 70 m. The deviations between switching upwards and switching downwards are likewise clearly significant. This shows that the

high contact resistances are actually caused by the switching contacts of the tap selector. No silver-plated contacts were originally used and the copper contact surface was now coated by oil carbon (Figure 12-17) [2].



Figure 12-17 Bad tap selector

After a full maintenance of the tap selector, no significant difference to the values measured at the factory in 1954 could be observed (Figure 12-18).

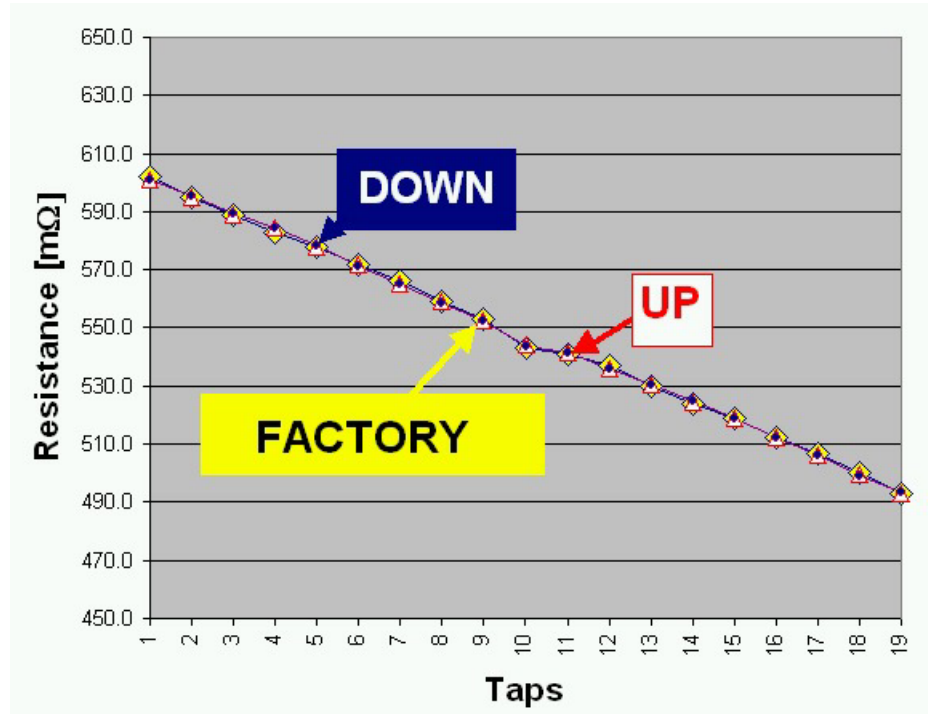

Figure 12-18 Resistance after maintenance

To examine the results in more detail, it is recommended to graph the difference between "UP" and "DOWN" values (Figure 12-19). The difference before contact maintenance was up to 30 m = 5% and after maintenance it was below 1m = 0.18%. Current maintenance practices require values to be measured only for the middle and two extreme taps, yet this test system has shown that this is

incomplete, with potentially serious consequences. To undertake a complete test to record the values for all taps with the described test equipment is not a significant effort.

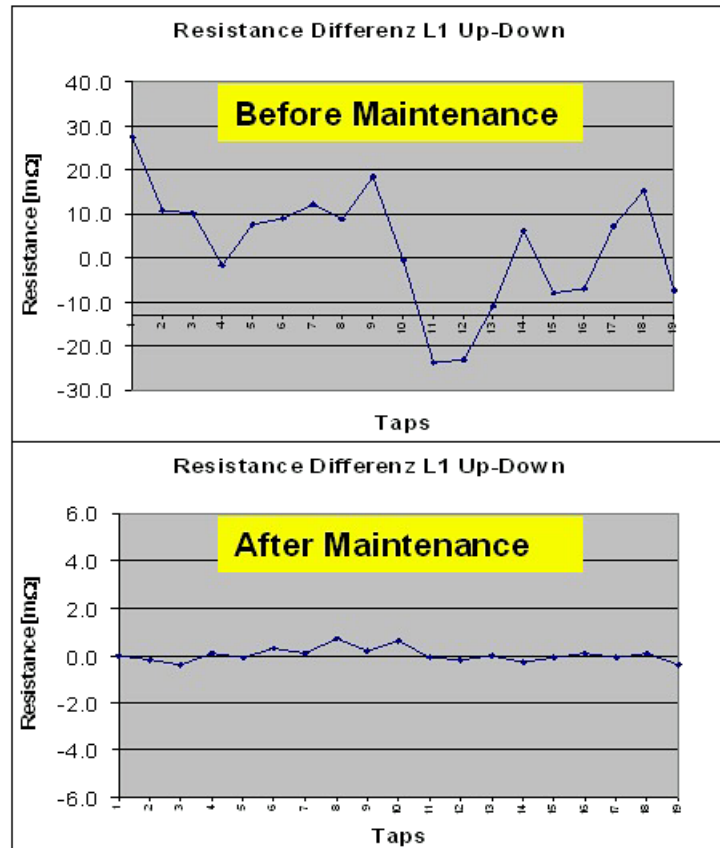

Figure 12-19 Difference "UP" - "DOWN"

12.9.9 Dynamic Behavior of the Diverter Switch

To date, only the static behavior of the contact resistances has been taken into account in maintenance testing. With a dynamic resistance measurement, the dynamic behavior of the diverter switch can be analyzed.

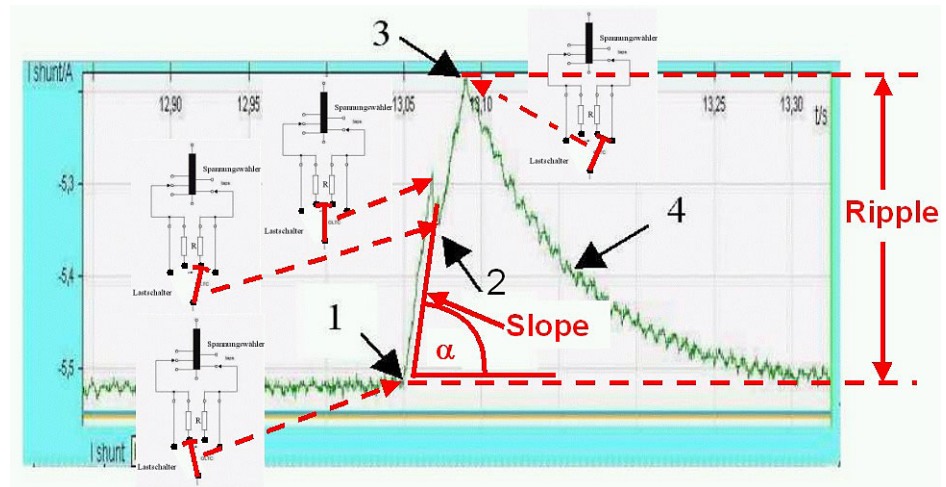

Figure 12-20 Dynamic resistance measurement for analysis of the diverter switch

- 1 = Diverter switch commutes from the first tap to the first commutation resistor
- 2 = The second commutation resistor is switched in parallel
- 3 = Commutation to the second tap (direct contact)
- 4 = Charging the additional windings

For the dynamic resistance measurement, the test current should be as low as possible otherwise short interruptions or bouncing of the diverter switch contacts cannot be detected. In this case, the initiated arc has the effect of shortening the open contacts internally. Comparison to "fingerprint" results, which were taken when the item was in a known (good) condition allows for an efficient analysis.

A glitch detector measures the peak of the ripple and the slope of the measuring current, as these are important criteria for correct switching (without bouncing or other short interruptions). If the switching process is interrupted, even if only for a short-time, the ripple ($= I_{\max} - I_{\min}$) and the slope of the current change (di/dt) increase. The values for all taps and particularly the values for the three phases are compared. Major deviations from the mean values indicate faulty

switching. For a more detailed analysis, a transient recorder can be used to record the current curve in real time. For this measurement, the transient recording functionality of the OMICRON *CMC 256* was used (Figure 12-20).

12.9.10 Turns Ratio

This test is normally only performed if a problem is suspected from the DGA, dissipation factor test or relay operation. The turns-ratio test detects shorted turns, which indicate insulation failure. Shorted turns may result from short circuits with high currents or insulation failures. The voltage ratio obtained by the test is compared to the boilerplate voltage ratio. The ratio obtained from the field test should agree with the factory value to within 0.5%. New transformers normally compare to the boilerplate within 0.1%. With the described test system, it is additionally possible to measure the ratio with magnitude and phase angle over a wide frequency range.

In the Figures 12-21 and 12-22, an analysis of a transformer with shorted turns in the low-voltage winding (Phase A) is shown.

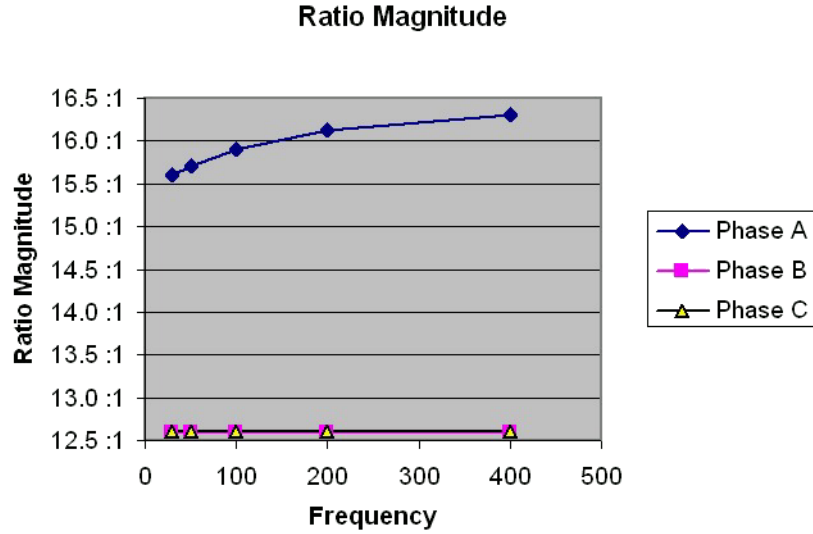

Figure 12-21 Ratio magnitude = $f(f)$

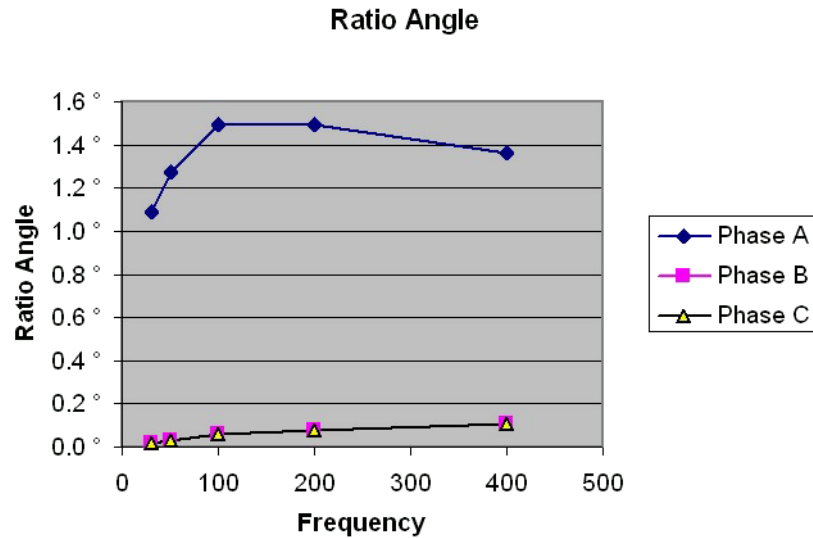

Figure 12-22 Ratio phase angle = $f(f)$

The large difference of approximately 20% indicates a failure with 20% of the turns. Due to the non-linear behavior, it can be assumed that the current, which is flowing through the low-voltage winding is partly flowing through the magnetic core. This can happen when the forces have significantly deformed the inner turns (Figure 12-23).

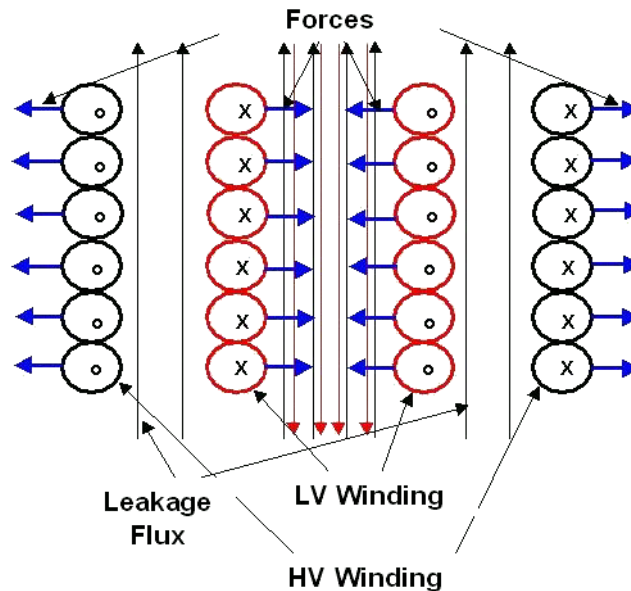

Figure 12-23 Leakage flux and forces during a fault

The winding is probably interrupted and parts of the winding are contacting the core which can be proven by measuring a resistance of 10m between LV winding and core. For intact windings, this ratio is nearly totally independent from the frequency in the discussed frequency range.

The ratio was measured with a test voltage of 200 V on the HV side. The excitation current of the defective phase was approximately 340 mA whereas the excitation current of the intact phases was approximately 10 mA.

12.9.11 Excitation Current

This test should be performed before any direct current (DC) tests. Results will be incorrect because of the residual flux of the core, which was initiated by the direct current.

By utilizing this test, short-circuited turns, poor electrical connections, core lamination shorts, tap changer problems and other possible core and winding problems can be detected. For a good interpretation of the results, comparison

to fingerprints is recommended. If no such test results are available, comparison should be made to transformers of similar design. On three-phase transformers, results are also compared between phases. On a three-phase, y-delta or delta-y transformer, the excitation current will be higher on the two outer phases than on the middle phase. Only the two higher currents can be compared. If the excitation current is less than 50 mA, the difference between the two higher currents should be less than 10%. If the excitation current is more than 50 mA, the difference should be less than 5%. In general, if there is an internal problem, these differences will be greater. In this case other tests will also show abnormalities, and an internal inspection should be considered.

12.9.12 Leakage Reactance

$$R_k(50\text{Hz}) = Z_k * \cos\varphi = \frac{U_k}{\sqrt{3} * I} * \frac{P_k}{\sqrt{3} * U * I}$$

$$X_k(50\text{Hz}) = Z_k * \sin\varphi = \frac{U_k}{\sqrt{3} * I} * \sqrt{1 - \left(\frac{P_k}{\sqrt{3} * U * I}\right)^2}$$

$$L_k(50\text{Hz}) = \frac{X_k}{2 * \pi * \omega}$$

with

P_k = the measured short circuit losses and

U_k = the measured short circuit voltage

The measurement of the short circuit impedance is done as part of the initial acceptance test in the factory. The leakage reactance can be calculated from the short circuit impedance. The difference between the average of L_k of the three phases should be within 3% of the calculated value from the short circuit impedance factory test. However, the percentage impedance should not vary more than 1% from any fingerprint results taken in a good condition.

After events such as through faults, nearby lightning strikes, other surges and transport of the transformer, this test is used in the field to detect winding deformation or displacement. This can lead to immediate transformer failure after a severe through fault, or a small deformation can lead to a failure several

years later. Leakage reactance testing is performed by short-circuiting the low-voltage winding, and applying a test voltage to the high-voltage winding (Figure 12-24).

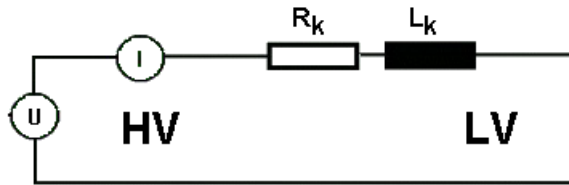

Figure 12-24 Short-circuit impedance test

Changes in leakage reactance and observed in capacitance tests (explained later) serve as an excellent indicator of winding movement and structural problems (displaced wedging, buckling, etc.). This test does not replace excitation current tests or capacitance tests, but complements them and they are often used together. The excitation current test relies on the magnetic resistance of the core while the leakage reactance test relies on the magnetic resistance of the leakage channel between the windings (Figure 12-24).

Using the test system, the leakage reactance can also be measured over the frequency range from 15 to 400 Hz. Intact windings show a nearly constant reactance value in this frequency range.

The transformer with the shorted LV winding (Figure 12-21 and 12-22), was used for the leakage reactance frequency scan (Figure 12-25). The faulty phase shows a totally different behavior. As already mentioned a part of the LV winding current is flowing through the core. In this case the leakage reactance depends on the frequency due to the skin effect.

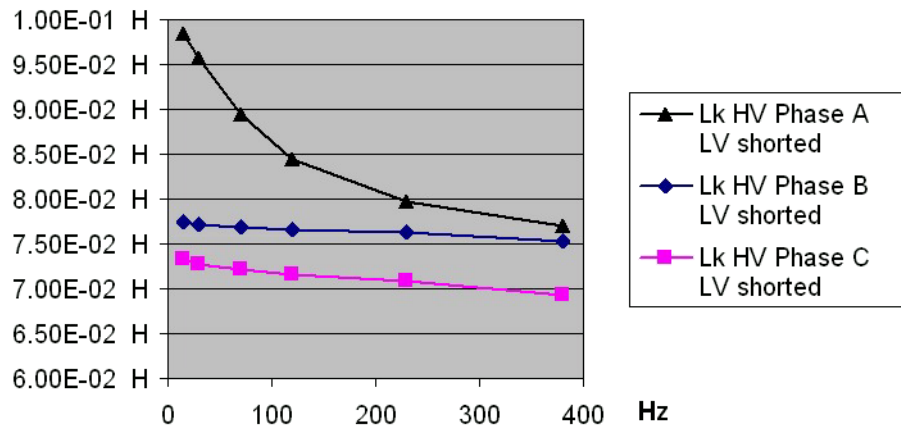

Figure 12-25 Leakage reactance frequency scan

12.9.13 Capacitance and DF Measurement

Capacitance (C) and Dissipation Factor (DF) measurement is an established and important insulation diagnosis method which was first published by Schering in 1919 [9] and utilized for this purpose in 1924. In a simplified diagram of the insulation C_p represents the capacitance and R_p the losses (Figure 12-26).

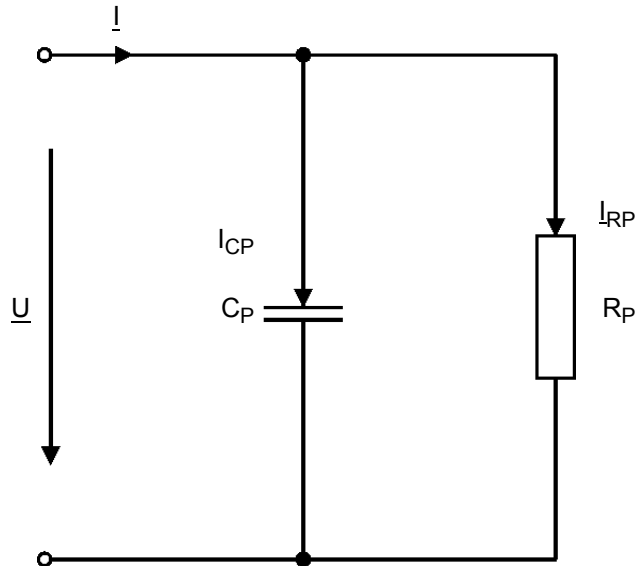

Figure 12-26 Simplified circuit diagram of a capacitor

The vector diagram of the system is shown in Figure 12-27.

$$\tan \delta = \frac{|I_{Rp}|}{|I_{Cp}|} = \frac{1}{1 \times \omega C_p}$$

with $\omega = 2 \times \pi \times f$

and $f = \text{frequency}$

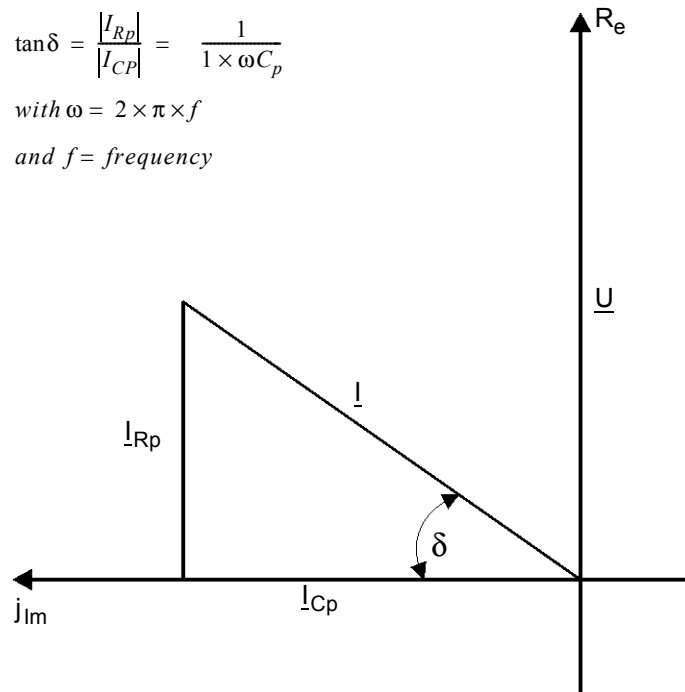

Figure 12-27 Definition of dissipation factor ($\tan \delta$) and the vector diagram

The first measuring device for tan delta was the mentioned Schering bridge [9] (Figure 12-28).

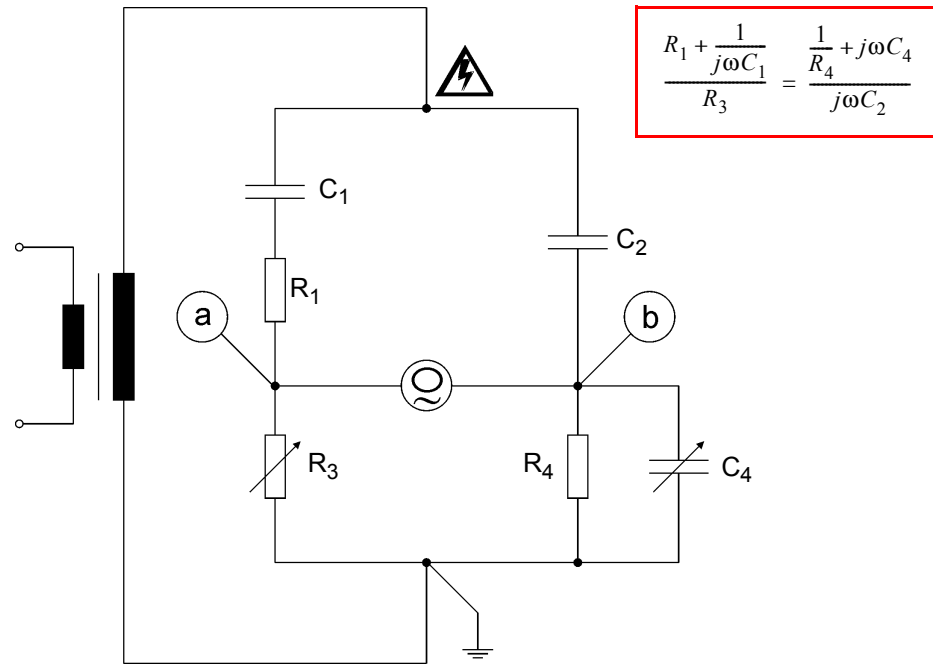

Figure 12-28 Schering bridge

Real parts: $\frac{R_1}{R_3} = \frac{C_4}{C_2} \Rightarrow R_1 = \frac{C_4}{C_2} \times R_3$

Imaginary parts: $C_1 \times R_3 = C_2 \times R_4 \Rightarrow C_1 = \frac{R_4}{R_3} \times C_2$

$$\tan \delta = R_1 \times \omega C_1$$

$$\tan \delta = C_4 \times \frac{R_3}{C_2} \times \omega \times \frac{R_4}{R_3} \times C_2$$

$$\tan \delta = \omega \times C_4 \times R_4$$

In Figure 12-28, the serial connected C_1 and R_1 represent the test object with losses, C_2 the loss-free reference capacitor. The parallel circuit diagram in Figure 12-26 can be transferred as a direct equivalent into this serial diagram at specified frequencies. The new test system utilizes a method similar to that of the Schering bridge. The main difference is that the system described in Figure 12-29 doesn't require tuning for measuring C and DF . C_N is a gas insulated reference capacitor with losses below $10E-5$.

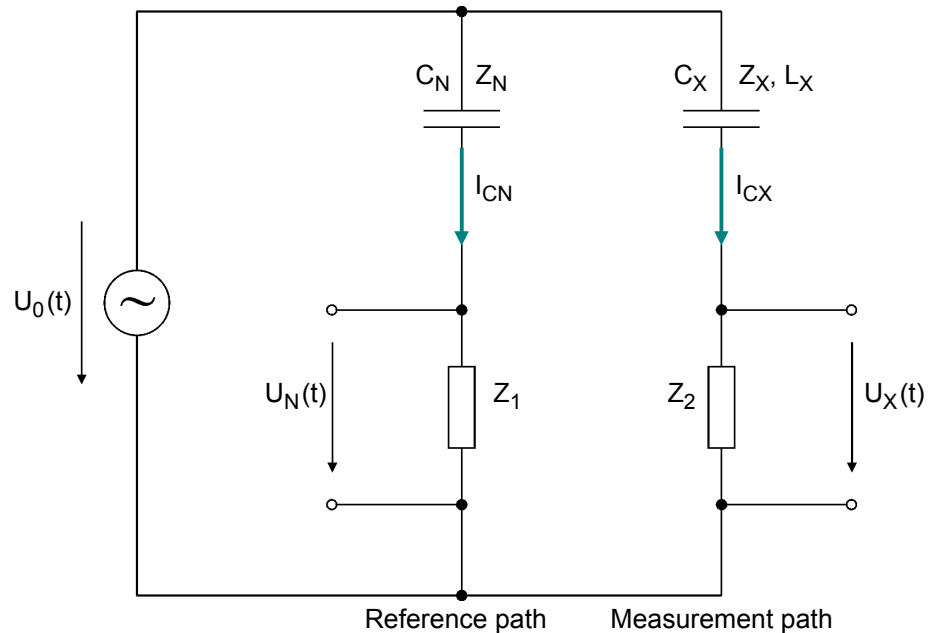

Figure 12-29 CP TD1 measuring principle

For laboratory use, such capacitors are regularly used to obtain precise measurements, as the climatic conditions are very constant. This is not the case for on-site measurements where temperatures can vary significantly, which leads to extension and contraction of the electrode length in the reference capacitor. The test system takes all these effects into account and compensates

for them electronically, so it is now for the first time possible to measure in the field down to $DF = 5 \times 10^{-5}$. The correlation between DF and power factor $= \cos \varphi$ and the vector diagram are shown in Figure 12-30.

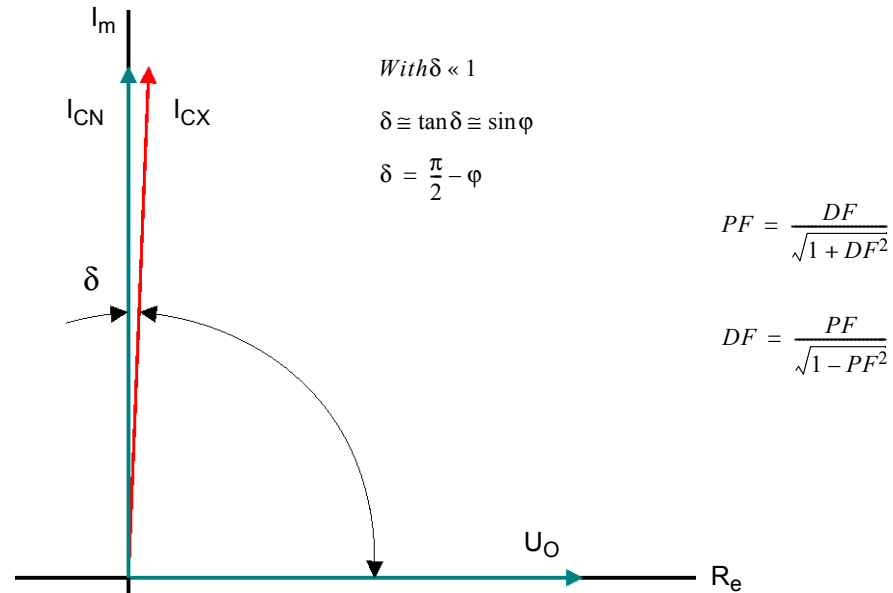

Figure 12-30 Correlation between DF and PF

To the present day, the dissipation or power factor was measured only at line frequency. With the power source described in [8], it is now possible to make these insulation measurements in a wide frequency range. Beside the possibility to apply frequency scans, measurements can be made at frequencies different from the line frequency and their harmonics. With this principle, measurements are possible also in the presence of high electromagnetic interference in high-voltage substations.

12.9.14 DF Measurements on Transformer Windings

A transformer contains a complicated insulation system. High- and low-voltage windings have to be insulated to tank and core (ground) and against each other. All these insulation gaps should be checked regularly.

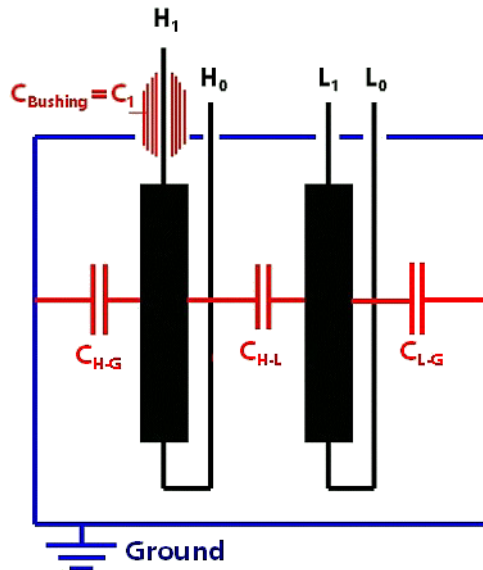

Figure 12-31 2-winding transformer

Normally in a two-winding power transformer, C-Tan-Delta measurements are made for all insulation gaps: HV to LV, HV to ground, LV to ground (Figure 12-31). A three-winding transformer is much more complicated and more tests are necessary to measure all gaps.

The dissipation factor is an indicator of the oil-paper insulation quality of the single gaps. Degradation of oil, water content and contamination with carbon and other particles can increase the DF. New HV-power transformers and transformers of good quality have values for DF below 0.5%. Figure 12-32 shows a DF measurement HV-winding to LV-winding.

The DF value for 60Hz is about 0.30%. The character of the DF curve over the frequency range is interesting and should be retained as a fingerprint result for future diagnosis of the insulation and its degradation.

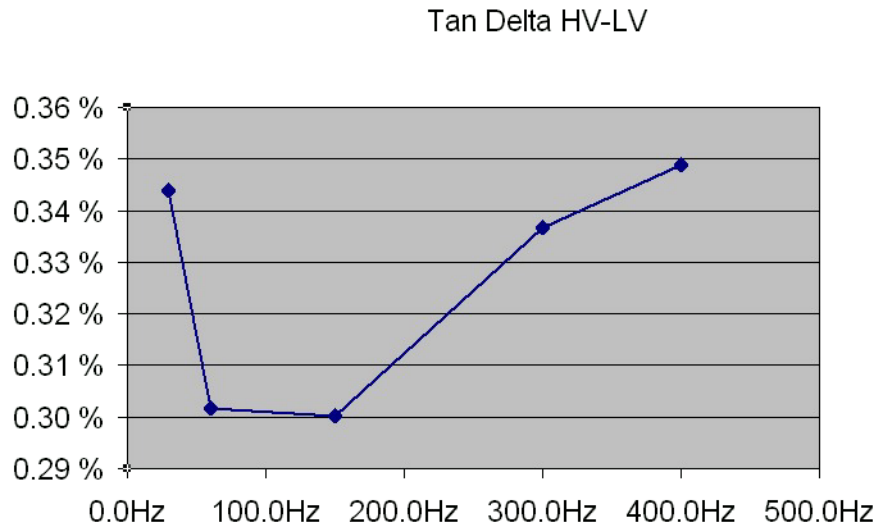

Figure 12-32 Frequency scan HV-LV (154 kV-20 kV)

12.9.15 Capacitance Measurements on Transformer Windings

The capacitance test measures the capacitance between the high- and low-voltage windings, between the high-voltage winding and the tank & core (ground), and between the low-voltage winding and the tank & core (ground). Nearby lightning strikes or through faults can cause a change of the measured capacitance values. This indicates winding deformation and structural problems such as displaced wedging and winding support.

12.9.16 Capacitance and DF Measurements on Transformer Bushings

The high-voltage bushings are critical components of the power transformer and particularly, capacitive high-voltage bushings need care and regular tests to avoid sudden failures. These bushings have a measurement tap-point at their base and both the capacitance between the top of the bushing and the bottom tap (normally called C1) and the capacitance between the tap and ground (normally called C2) are measured. An increase of C1 indicates partial breakdowns of the internal layers.

Figure 12-33 shows the change of C1 for different types of bushings:

- "Resin-impregnated paper (RIP)
- "Oil-impregnated paper (OIP) and
- "Resin-bonded paper (RBP).

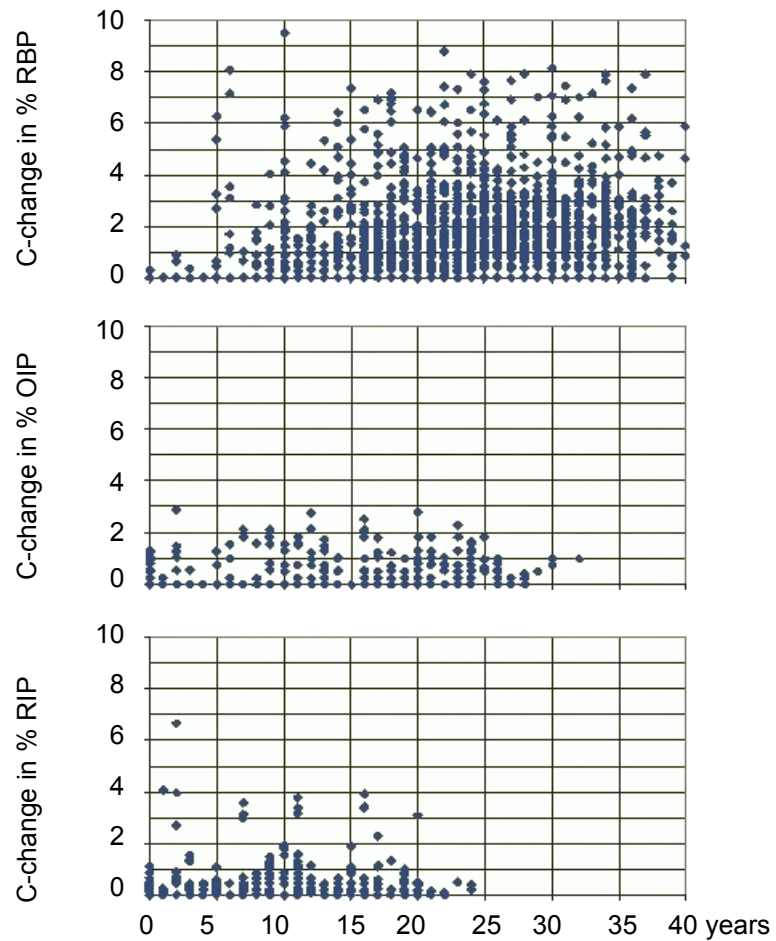

Figure 12-33 Aging of RBP, RIP and OIP bushings (change of capacitance) [10]

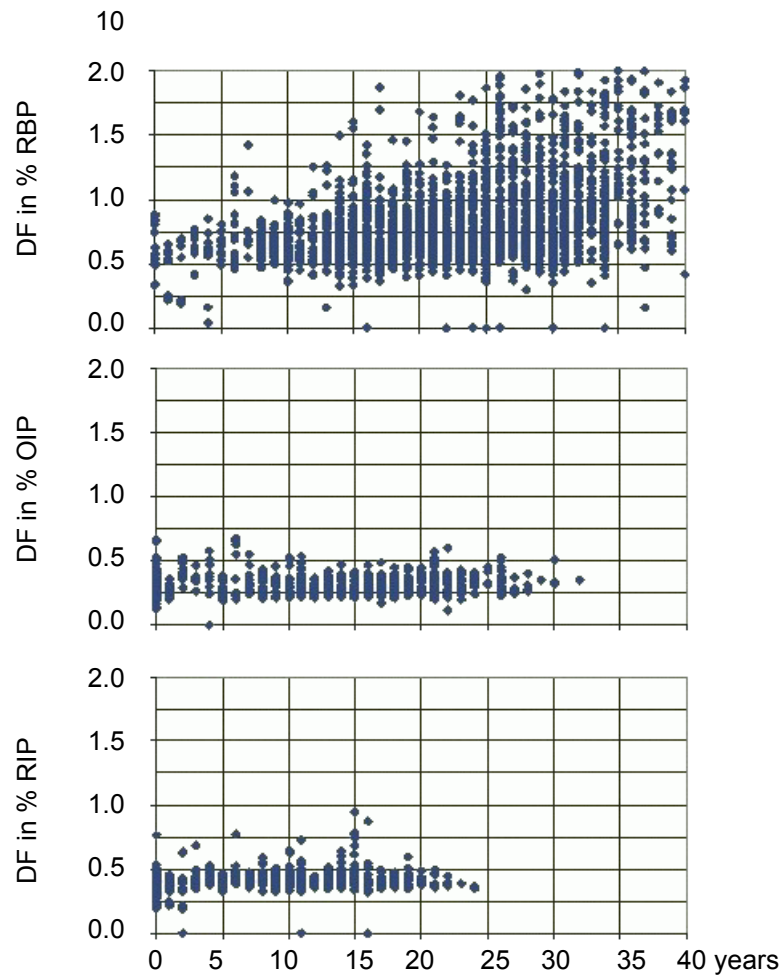

Figure 12-34 Aging of RBP, RIP and OIP bushings (change of DF)

To determine bushing losses, dissipation factor tests are also performed. Figure 12-34 shows the increase of losses for RIP-, OIP-, and RBP-bushings. RBP-bushings particularly show a significant change of capacitance and dissipation factor during their life-time [10].

About 90% of bushing failures may be attributed to moisture ingress. As already shown with the winding-to-winding insulation, analysis of bushing insulation is much more detailed when frequency scans are performed. Figures 12-35 to 12-37 show interesting DF curves of power transformer HV bushings over frequency.

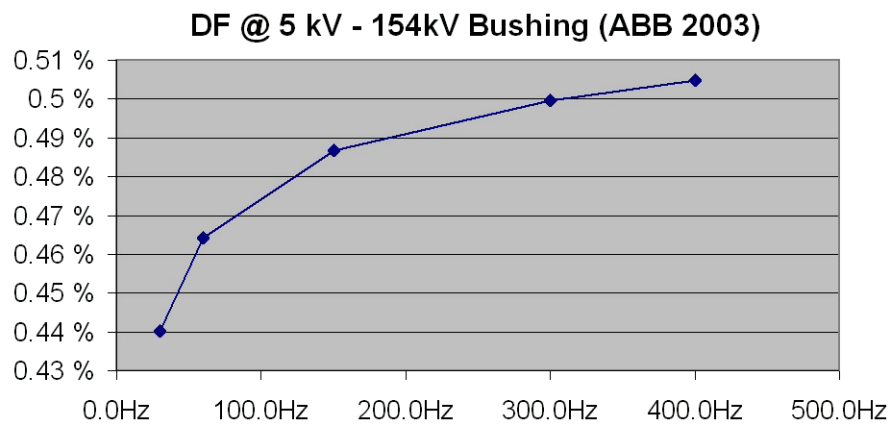

Figure 12-35 DF of a new 154 kV bushing

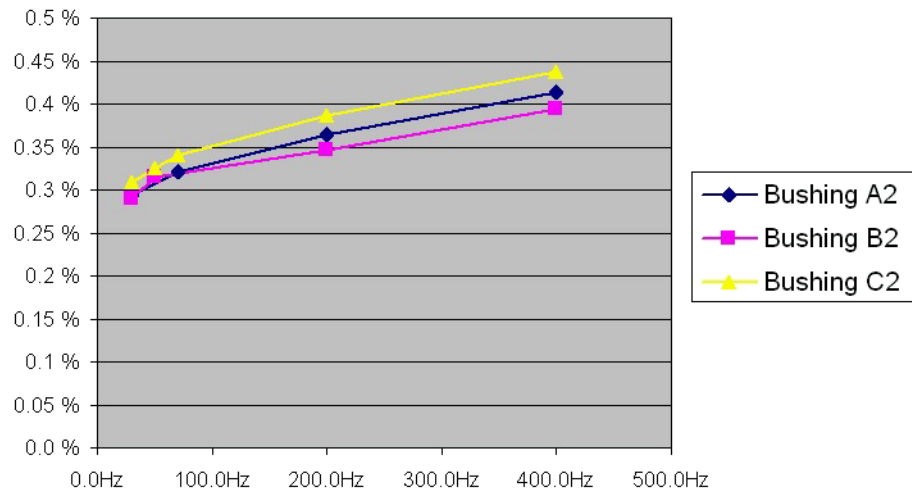

Figure 12-36 DF of a RIP 145 kV bushing (MICAFIL new)

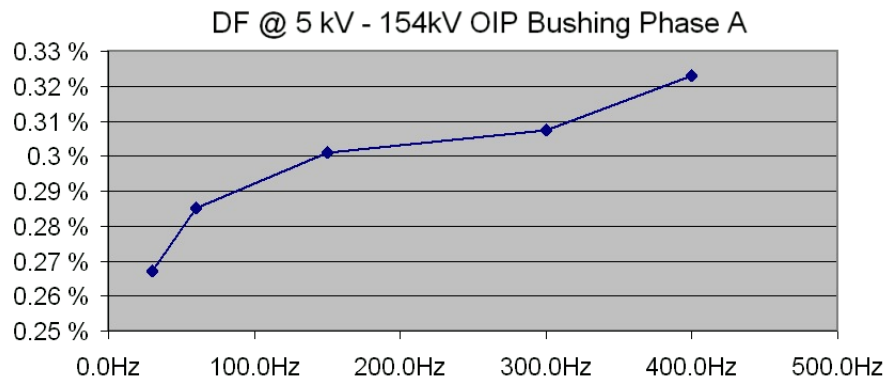

Figure 12-37 DF of an OIP 154 kV bushing (1970)

These results show that the frequency scan method will enable more detailed insulation analysis in the future. But it is necessary to compare the curves to fingerprint measurements. This way it will be possible to detect changes in insulation at a very early stage.

12.9.17 Summary

With advancing age of transformers, a regular check of the operating condition becomes more and more important. The analysis of the gas in oil is well-proven method of analysis but must be complemented by efforts to locate any faults indicated by excess hydrocarbon gases in the oil. This way important maintenance can be performed in time to avoid a sudden total failure. The fault location can be successfully performed using simple electrical methods, such as resistance measurements.

The described new test technology enables DF frequency scans which, by comparing DF curves to fingerprints it will be possible to detect degradation in insulation at a very early stage with a more detailed analysis. Additionally, excellent suppression of electromagnetic interference is guaranteed.

With the described system, other interesting tests can be performed such as zero sequence measurements without additional equipment; current transformers can be tested up to 2000A (ratio, polarity, excitation curve, burden ...); voltage transformers can be tested up to 2000V, contact resistances, ground and line impedances can be measured and a lot of additional applications are possible.

All measurements can be performed quickly and efficiently with automatic test procedures enabling simple operation such that all results are saved in one system. Essentially, the whole test report and diagnosis can be created automatically.

12.10 References

- [1] Weck, K.-H.: Instandhaltung von Mittelspannungs-verteilnetzen, Haefely Symposium 2000, Stuttgart
- [2] Seitz, V.: Vorbeugende Instandhaltung an Leistungstransformatoren – Betriebsbegleitende Messungen an Stufenschaltern und Durchführungen, OMICRON Anwendertagung 2003, Friedrichshafen
- [3] CIGRE-WG 12-05: An international survey on failures in large power transformers in service, Electra No. 88 1983, S. 21-48
- [4] Dörnenburg, E., Hutzler, O.: Betriebsüberwachung durch Untersuchungen des Isolieröls, etz-a, Bd. 98 1977 H.3, S. 211-215
- [5] Müller, R., Schliesing, H., Soldner, K.: Prüfung und Überwachung von Transformatoren durch Analyse der im Öl gelösten Gase, Sonderdruck aus Elektrizitätswirtschaft, Trafo Union Nürnberg, 1981, TU 81.5.19/1.75
- [6] Foschum, H.: Erfahrungsbericht zur Gasanalyse an Öltransformatoren, ELIN-Zeitschrift 1980, Heft ½, S. 17-26
- [7] Möllmann, A., Lütge, H.: IEC / VDE Standards für flüssige Isolierstoffe zur Diagnostik von Transformatoren und Wandlern, ETG-Fachbericht "Diagnostik elektrischer Betriebsmittel", VDE-Verlag GmbH Berlin 2002, S. 205-210
- [8] Hensler, Th., Kaufmann, R., Klapper, U., Krüger, M., Schreiner: S., 2003, "Portable testing device", US Patent 6608493
- [9] Schering, H.: "Brücke für Verlustmessungen", Tätigkeitsbericht der Physikalisch-Technischen Reichsanstalt, Braunschweig 1919
- [10] Sundermann, U.: "Transformer life cycle management" 1.Symposium Geriatrie des Transformators, Regensburg 2002

12.11 Temperature Correction Factors

The temperature curves can be used in the **TanDelta** test card (see 3.4 "TanDelta Test Card - Settings Page (2/2)" on page 30).

$$PF(DF)_{20} = PF(DF)_T \times k$$

where

$PF(DF)_{20}$ is the corrected Power Factor (Dissipation Factor) to 20 °C

$PF(DF)_T$ is the Power Factor (Dissipation Factor) measured at T

k is the correction factor

12.11.1 Transformers

IEEE Std. C57.12.90

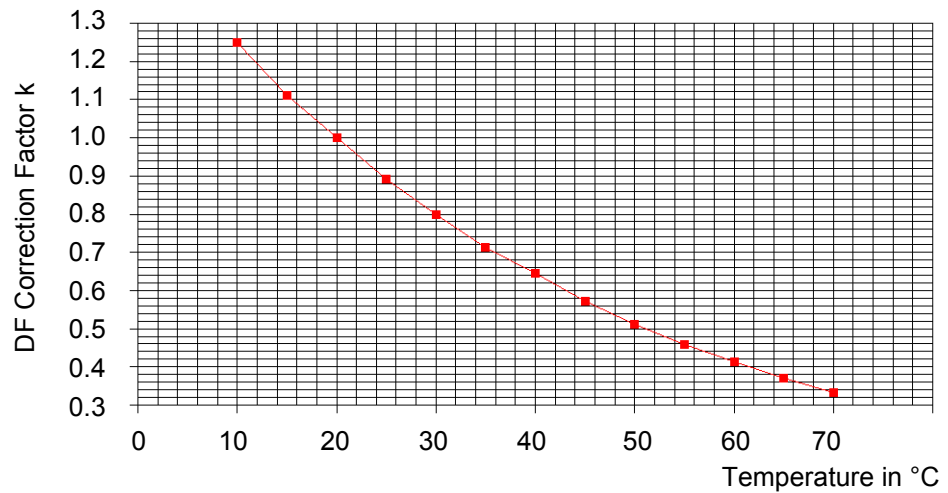

12.11.2 Bushings

The temperature curves apply to medium-aged bushings and are determined by long-time studies of a utility.

Resin Impregnated Paper (RIP)

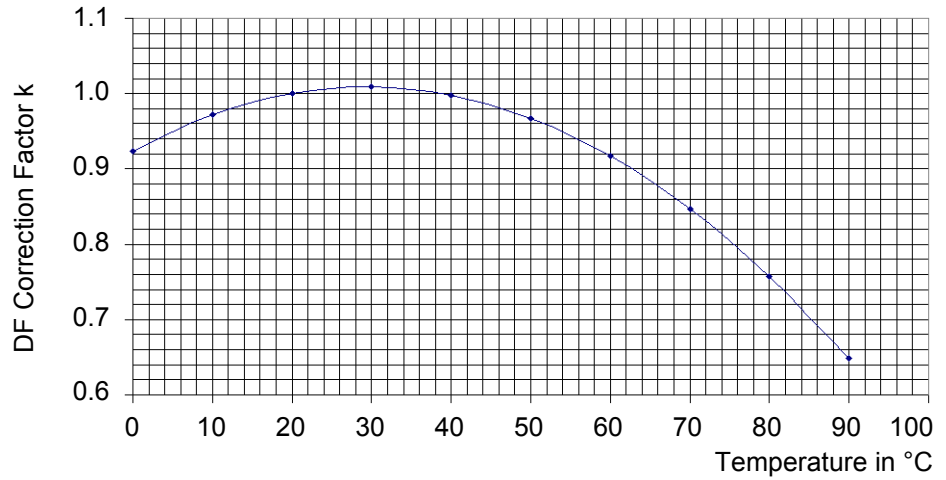

Resin Bonded Paper (RBP)

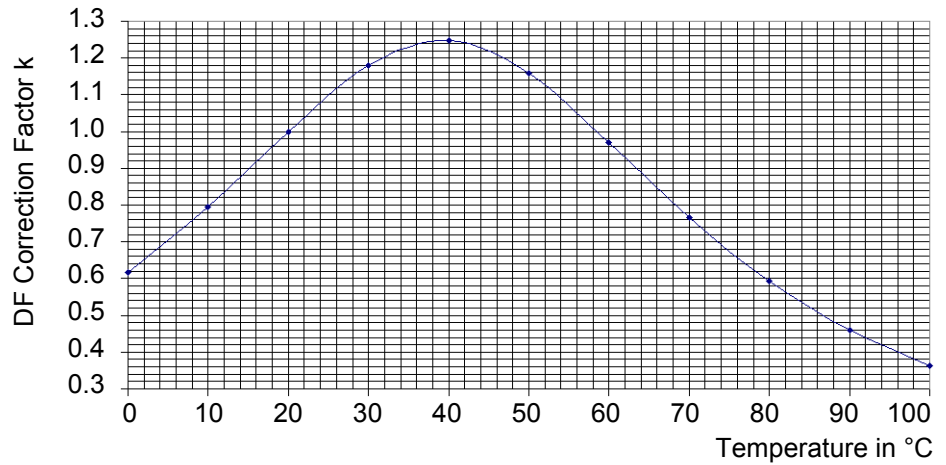

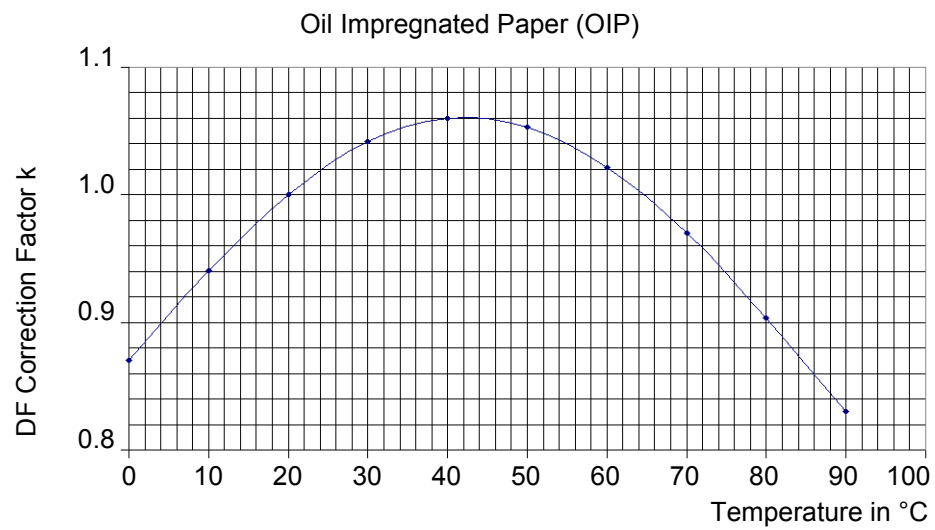

OMICRON Service Centers

Americas

OMICRON electronics Corp. USA

3550 Willowbend Blvd.
Houston, TX 77054, USA
Phone: +1 713 830-4660
1 800-OMICRON
Fax: +1 713 830-4661
techsupport@omicronusa.com
www.omicronusa.com

Asia – Pacific

OMICRON electronics Asia Ltd.

Suite 2006, 20/F, Tower 2
The Gateway, Harbour City
Kowloon, Hong Kong S.A.R.
Phone: +852 3767 5500
Fax: +852 3767 5400
support@asia.omicron.at
www.omicron.at

Europe, Middle East, Africa

OMICRON electronics GmbH

Oberes Ried 1
A-6833 Klaus, Austria
Phone: +43 5523 507-333
Fax: +43 5523 507-999
support@omicron.at
www.omicron.at

For addresses of OMICRON electronics offices with customer service centers, regional sales offices or offices for training, consulting and commissioning please visit our Web site.

Index

A

auto test points
 at TanDelta test card 25

C

capacitor
 reference capacitor for CP TD1 23
 contact information 185
 CP CAL1 calibration set 23
 CP TD1
 optional test system 15, 21, 25, 119

D

dimensions
 CP TD1 122

G

GST
 measuring modes (CP TD1 / TanDelta) . 27

H

high voltage
 plug at CP TD1 11
 hotline 185

I

IEC 68-2-78 123

M

maintenance 9
 measuring modes
 UST & GST (CP TD1 / TanDelta) 27

O

ordering information
 calibration set CP CAL1 127
 CP TD1 127
 TH 3631 127

Q

qualification of operating personnel 7

R

reference capacitor for CP TD1 23
 repair 9

S

safety
 instructions 7
 internal 7
 qualification of operating personnel 7
 rules 9–13
 standards 7
 standards

safety 7
substation
 preparation prior to test 23, 36
support 185

T

TanDelta
 test card 25
technical data
 weight and dimensions (CP TD1) 122
technical support 185
temperature
 temp. measuring unit TH 3631 126
test
 grounding set for test object 23, 36
 preparation of substation 23, 36
test card TanDelta 25
test object
 preparation prior to test 23, 36
TH 3631
 optional temp. measuring unit 126
trolley
 setting CP TD1 into operation without trolley
 34
trolley for CP TD1 21

U

UST
 measuring modes (CP TD1 / TanDelta) . 27

W

warranty claims 11
weight
 CP TD1 122
