

4M200

TEST BLOCKS | TEST PLUGS | TEST LEADS

Test Block System

Flexible and high-performance test block system suitable for application on a wide range of protection relay panels.

- > Colour coded finger safe test sockets
- > 14 independent test groups
- > Compatible with industry standard 14 circuit test blocks and test plugs
- > Optional auxiliary supply isolation circuit
- > Identification of CT circuits on front panel
- > Flush panel or rack mounting
- > IEC 60255 Compliant
- > Optional test plug to block polarizing system
- > Made in Australia
- > <http://rmspl.com.au/product/4m200>

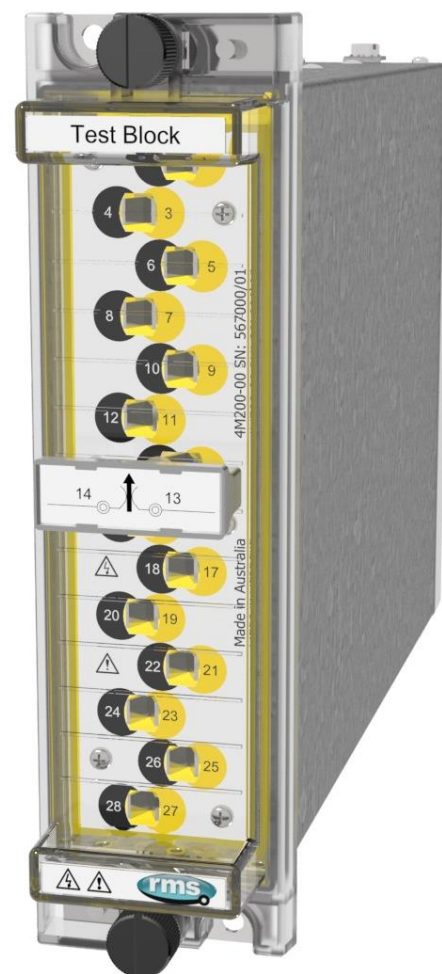

4M200-01 Test Block

System Components

- > 14 circuit Test Block
- > Test Plug



4M200-06 Test Block



4M220-00 Test Plug

Description

The 4M200 Test Block system is an evolution of the 14 test circuit versions widely employed in the power utility sector. The primary difference is the incorporation of 'finger safe' test sockets which allow the use of shrouded 4mm banana plugs.

Several 4M200 Test Block configurations are available to suit specific protection and control applications as depicted in the wiring diagram examples.

The 4M200 Test Block has 14 pairs of spring loaded contacts which are linked to a terminal block positioned at the rear of the enclosure.

Insertion of the 4M220 Test Plug into the Test Block first connects & then open circuits each pair of contacts which connected to the rear terminals.

The 4M220 test plug locates securely into the test block & can be retained by two knurled screws.

The 28 'finger safe' test sockets on the 4M220 are divided into two groups of 14:

- > 14 even numbered equipment side **BLACK** test sockets
- > 14 odd numbered live side **YELLOW** test sockets

Each of these 28 test sockets accepts a 4mm shrouded or standard type test plug.

Features

- > 14 independent test groups
- > 'Finger safe' test sockets suit standard or shrouded type 4mm banana plugs for direct access to the protection or measurement scheme
- > Auto CT shorting test plugs available
- > Clear and concise front panel circuit identification
- > High current / voltage rating
- > Compatible with industry standard 14 circuit test blocks and test plugs
- > Made in Australia

Application

Test blocks enable test technicians to quickly and safely isolate protection relays so that test signals may be injected and system performance verified.

There are several advantages in performing injection tests at the protection relay panel:

- > Reduction in down time of the equipment under test
- > Testing does not cause disturbance to wiring, terminals or equipment settings
- > Existing auxiliary supply to the equipment under test may be isolated

The 4M200 Test Block is designed as a general-purpose isolation and test signal injection point. 'Finger safe' sockets are employed to improve operator safety and suit 4mm shrouded 'finger safe' type banana plugs.

Equipment under test need only be removed for servicing if problems are detected or for routine maintenance.



Finger Safe Test Sockets

Note the black - even numbered - equipment side sockets.

Note the yellow - odd numbered - live side sockets.



Figure 1: Close up view of the 'finger safe' test plug sockets that accept standard 4mm shrouded test plugs.

CT Shorting – Manual (External)

It is essential that the sockets of the 4M220 Multi-Finger Test Plug which correspond to the current transformer (CT), secondary windings are linked prior to the test plug being inserted into the test block.

This may be achieved using external shorting link lead to ensure that CT secondary windings are short circuited before they are disconnected from the protection relay or scheme, thereby avoiding dangerously high voltages.

The continuity of the shorting plug / wire links & their state of insulation should be checked prior to into the 4M200 test block.

The 4M220-00 Test Plug is for use with the 4M200-01 to -09 non-polarized Test Block versions

CT Shorting – Automatic (Internal Links)

The 4M220 may be ordered with internal CT shorting links fitted to pre-designated positions as follows:

4M220-P7 Can only be used with 4M200-P7 test blocks

Internal shorting links between contacts:
21-23-25-27

4M220-P8 Can only be used with 4M200-P8 test blocks

Internal shorting links between contacts:
1-3, 5-7, 9-11, 15-17

4M220-P9 Can only be used with 4M200-P9 test blocks

Internal shorting links between contacts:
1-3-5-7, 9-11, 17-19, 21-23-25-27

Where these 4M220 test plug versions are employed it is essential that the CT circuits are wired to the 2RMLG test block in the matching positions.

To Reiterate: The 4M220-00 requires the **USER** to ensure that the necessary shorting links are in the correct positions **BEFORE** plugging into the test block.

Test Plug Insertion



Before use the insulation of the flying leads should be visibly checked for damage.

Flexible banana test leads with shrouded plugs are recommended for operator safety. 2.5mm² multi-strand wire with PVC insulation is recommended for adequate current rating and flexibility.

To avoid high voltage shock hazard external CT circuits must NOT be open circuited. Shorting links must be in position **BEFORE** test plug insertion.

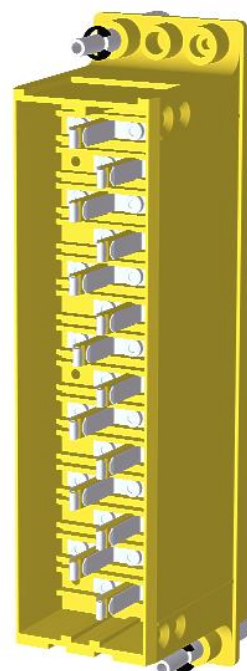

Figure 2: Rear view of the 4M220 showing connection fingers that interface with the 4M200 test block.

The 'hook' shape of the odd side connection fingers ensures 'make before break' functionality when inserting into the test block. This function is provided to ensure the continuity of CT circuits is maintained during insertion of the test plug.

Insertion of the 4M220 connects the live side circuits to the YELLOW test sockets on the front panel. The equipment side circuits are connected to the BLACK test sockets on the front panel. Each test socket is identified by a number, which corresponds to the numbered terminal on the rear of the case when the Test Plug is inserted.

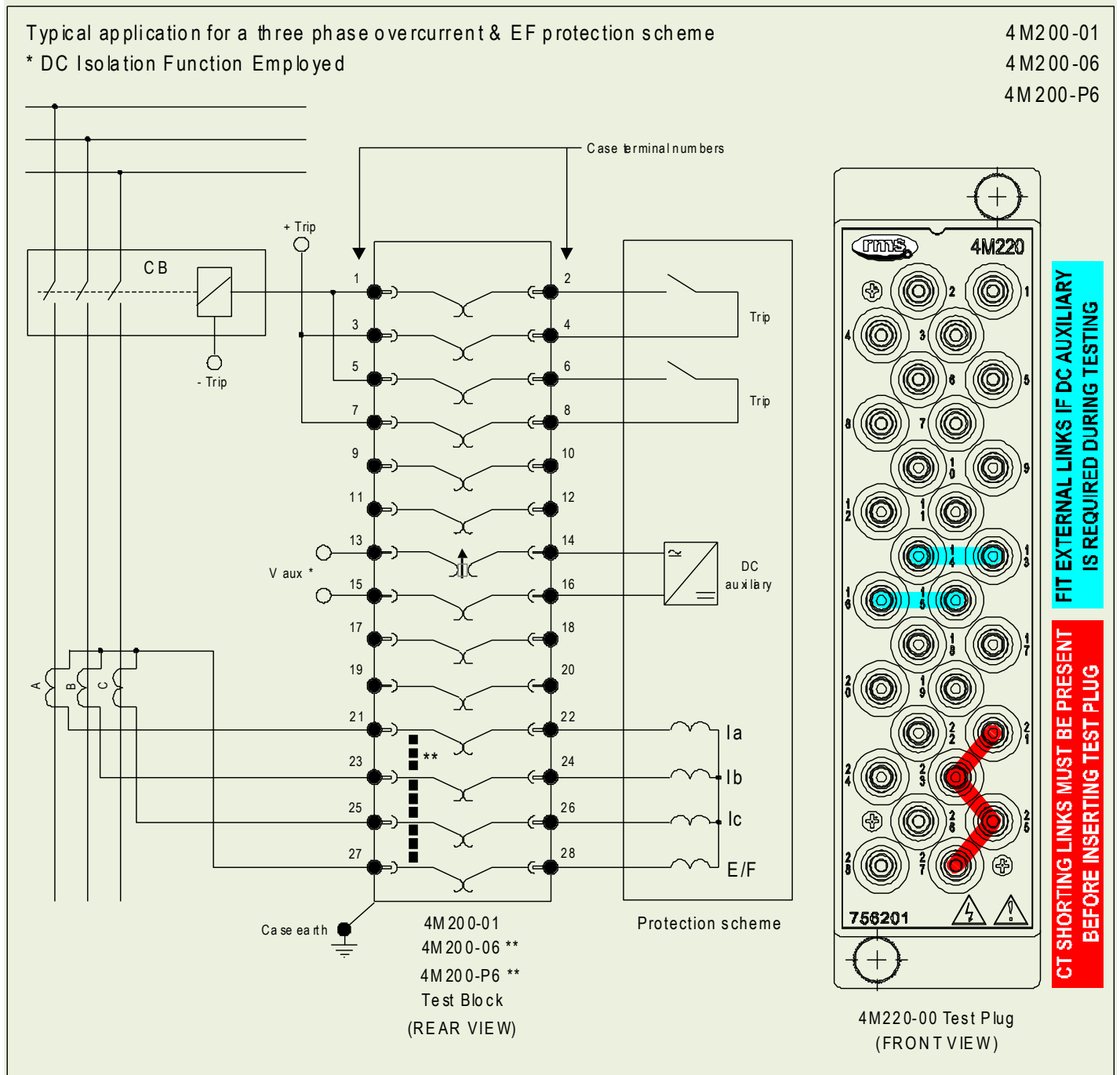

Figure 3: Test Block Application wiring example for a three phase overcurrent and EF protection scheme

Test Block	DC Isolation	Fixed CT Positions ** Designation on Test Block Facia	Polarized	Test Plug	Comment
4M200-01	YES	NO	NO	4M220-00	Operator must manually fit CT shorting links to the Test Plug in correct positions.
4M200-06		YES			
4M200-P6		YES	YES	4M220-P7	Test Plug has fixed shorting positions to terminal 21-23-25-27

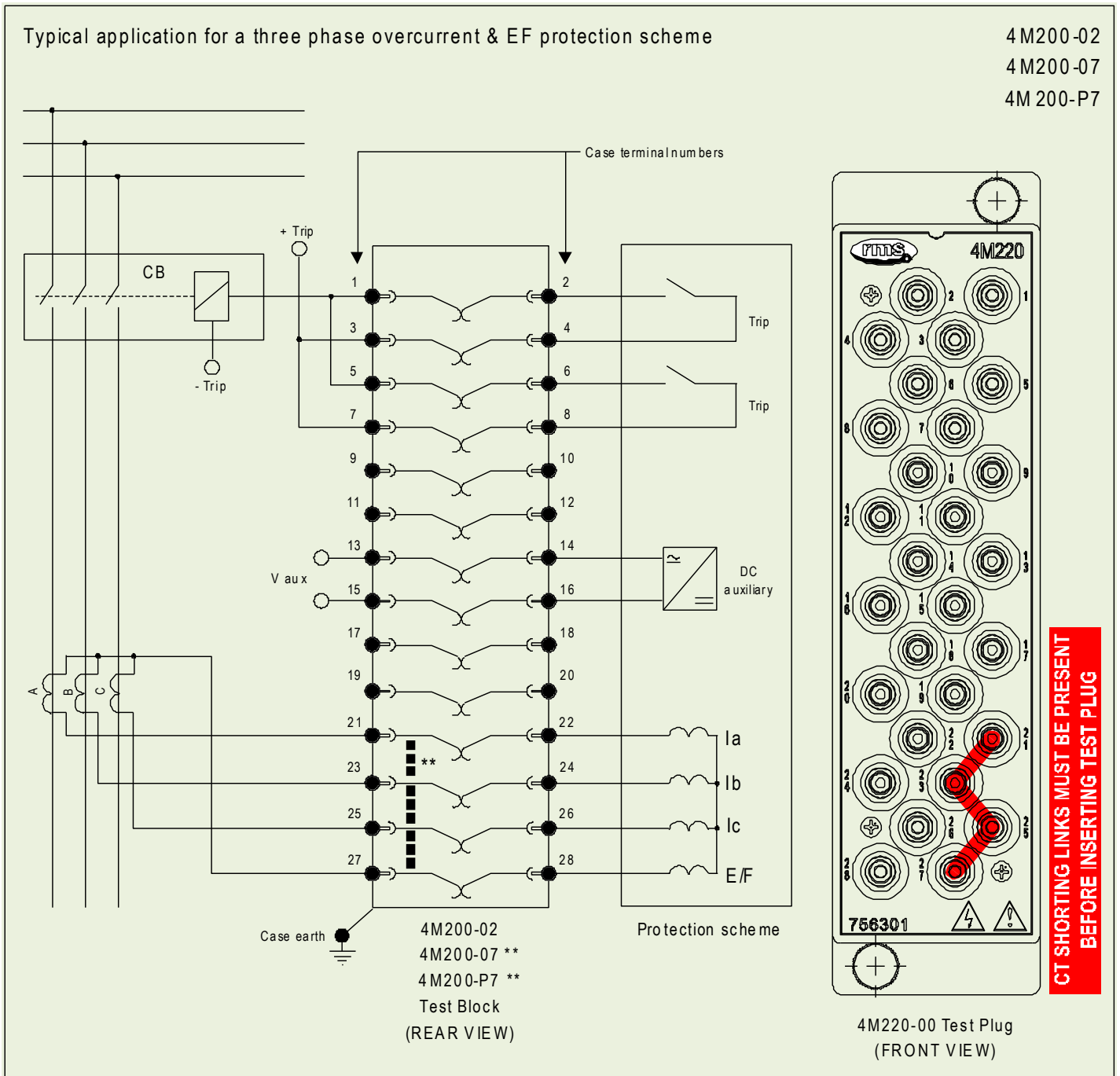

Figure 4: Test Block Application wiring example for a three phase overcurrent and EF protection scheme

Test Block	DC Isolation	Fixed CT Positions ** Designation on Test Block Facia	Polarized	Test Plug	Comment
4M200-02	NO	NO	NO	4M220-00	Operator must manually fit CT shorting links to the Test Plug in correct positions.
4M200-07		YES			
4M200-P7		YES	4M220-P7	Test Plug has fixed shorting positions to terminals 21-23-25-27	

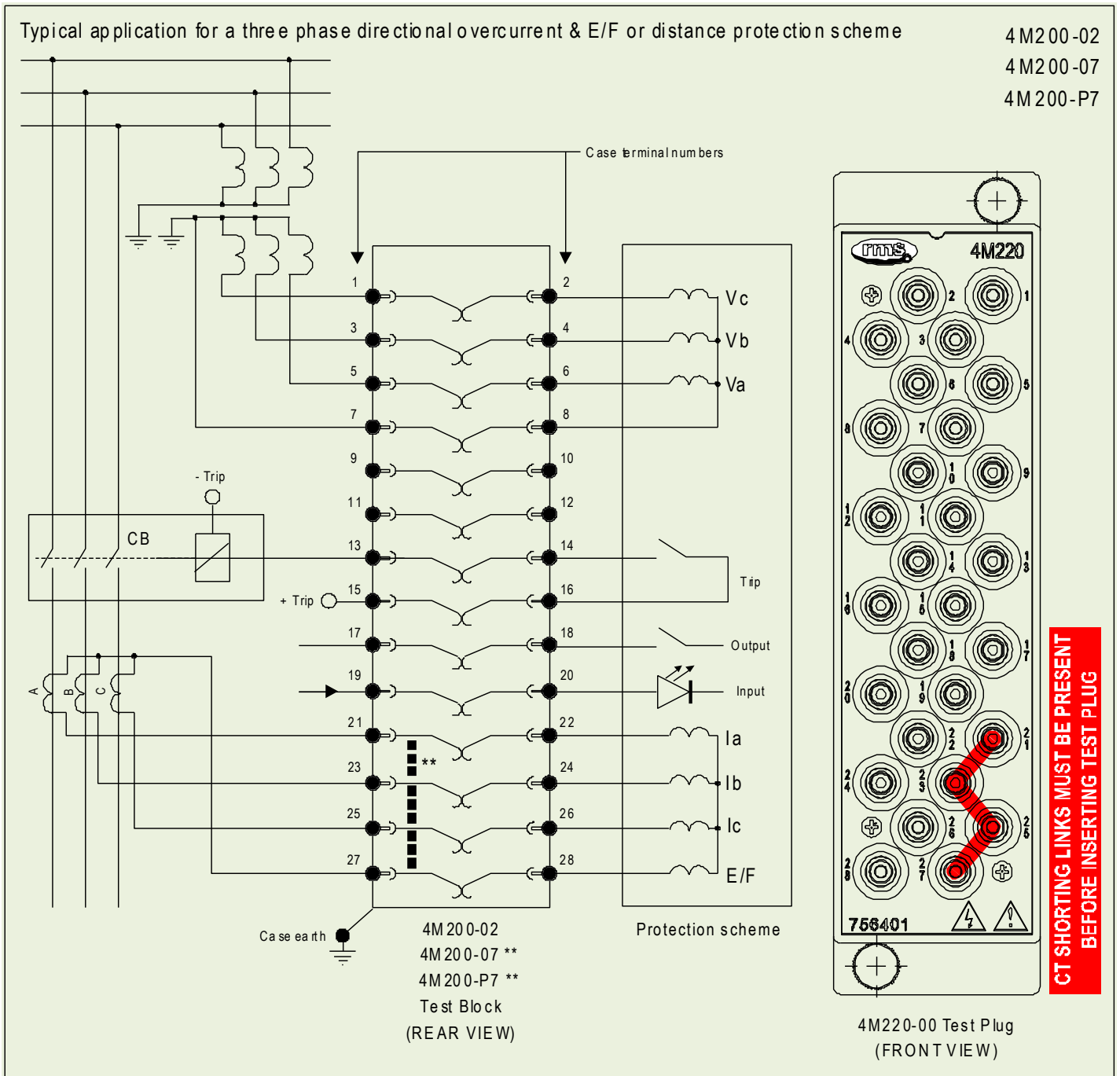

Figure 5: Typical application for a three phase directional overcurrent & E/F or distance protection scheme

Test Block	DC Isolation	Fixed CT Positions ** Designation on Test Block Facia	Polarized	Test Plug	Comment
4M200-02	NO	NO	NO	4M220-00	Operator must manually fit CT shorting links to the Test Plug in correct positions.
4M200-07		NO			
4M200-P7		YES	YES	4M220-P7	Test Plug has fixed shorting positions to terminals 21-23-25-27

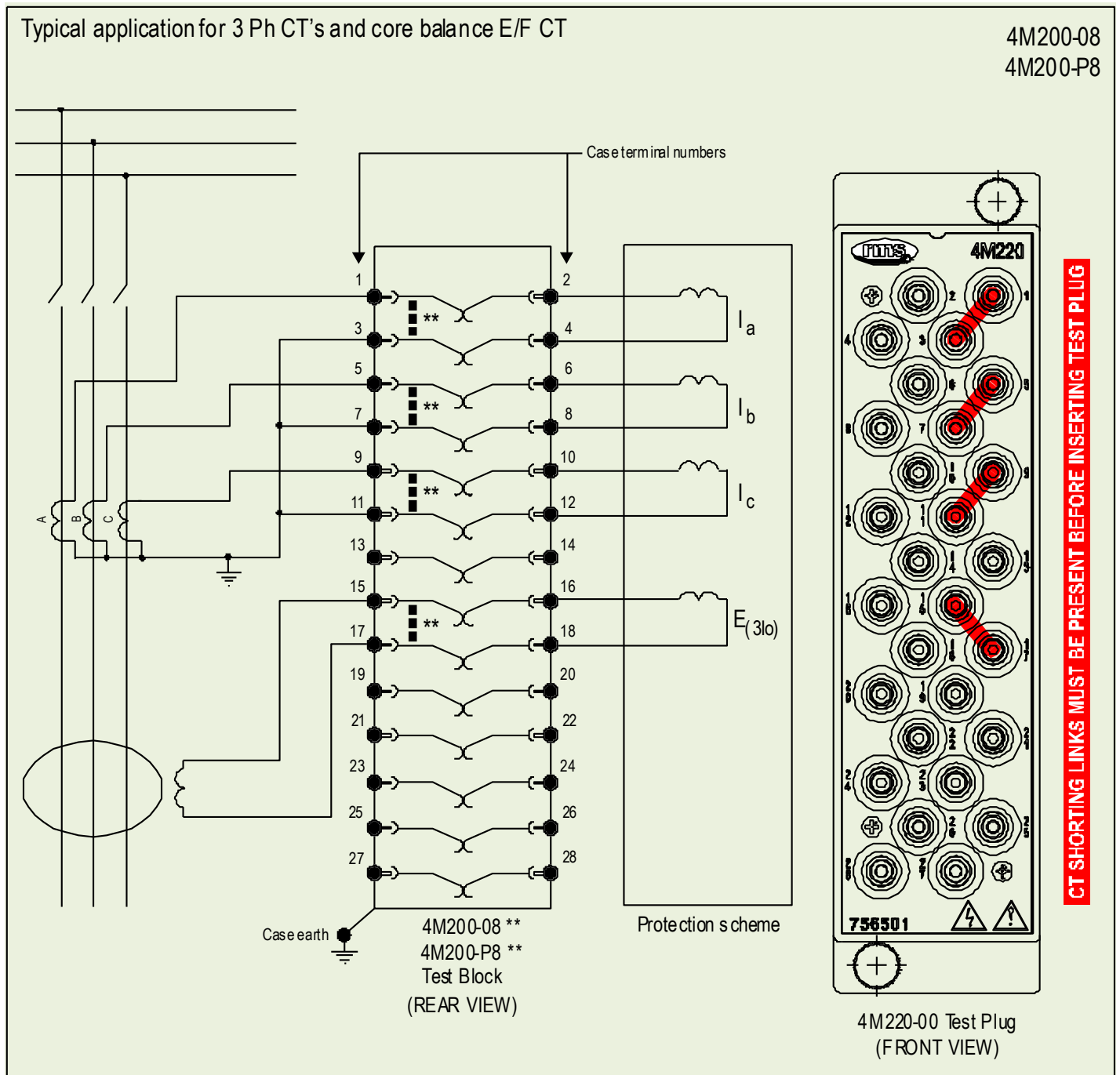

Figure 6: Typical application for 3 Ph CT's and core balance E/F CT

Test Block	DC Isolation	Fixed CT Positions ** Designation on Test Block Facia	Polarized	Test Plug	Comment
4M200-08	NO	YES	NO	4M220-00	Operator must manually fit CT shorting links to the Test Plug in the designated positions.
4M200-P8			YES	4M220-P8	Test Plug has fixed shorting positions to terminals 1-3, 5-7, 9-11, 15-17

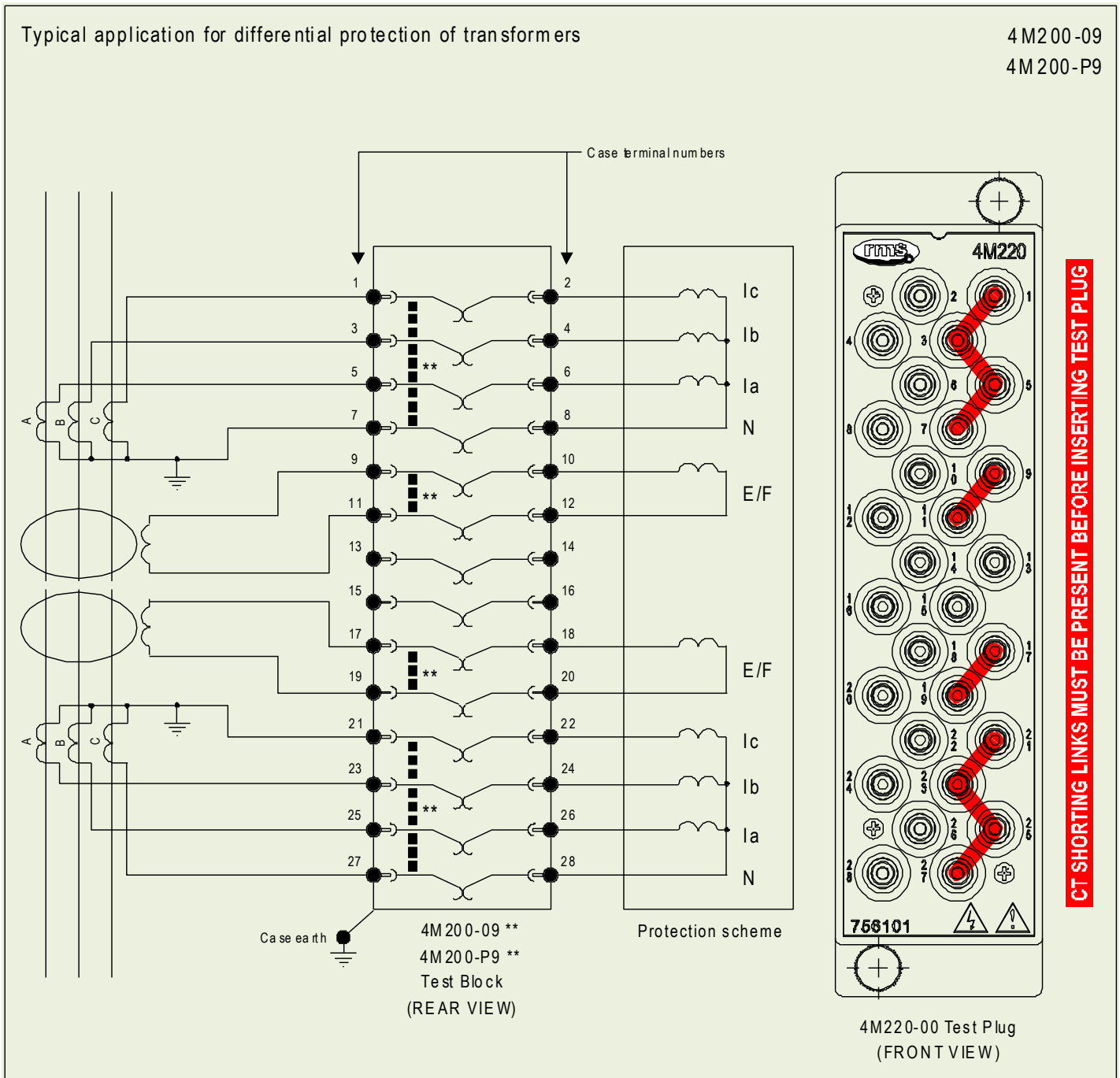
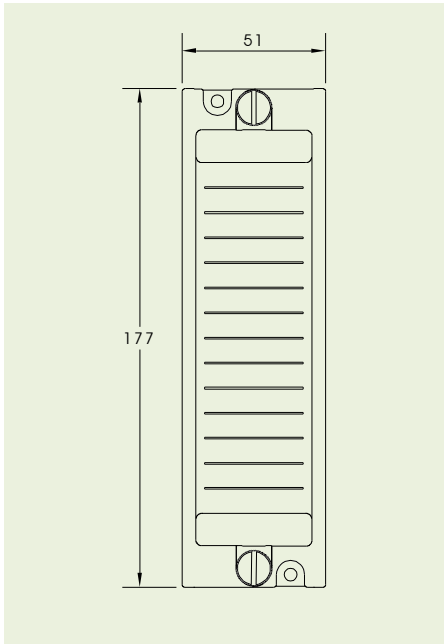

Figure 7: Typical application for differential protection of transformers

Test Block	DC Isolation	Fixed CT Positions ** Designation on Test Block Facia	Polarized	Test Plug	Comment
4M200-09	NO	YES	NO	4M220-00	Operator must manually fit CT shorting links to the Test Plug in the designated positions.
4M200-P9			YES	4M220-P9	Test Plug has fixed shorting positions to terminals 1-3-5-7, 9-11, 17-19, 21-23-25-27

Front View



Rear View

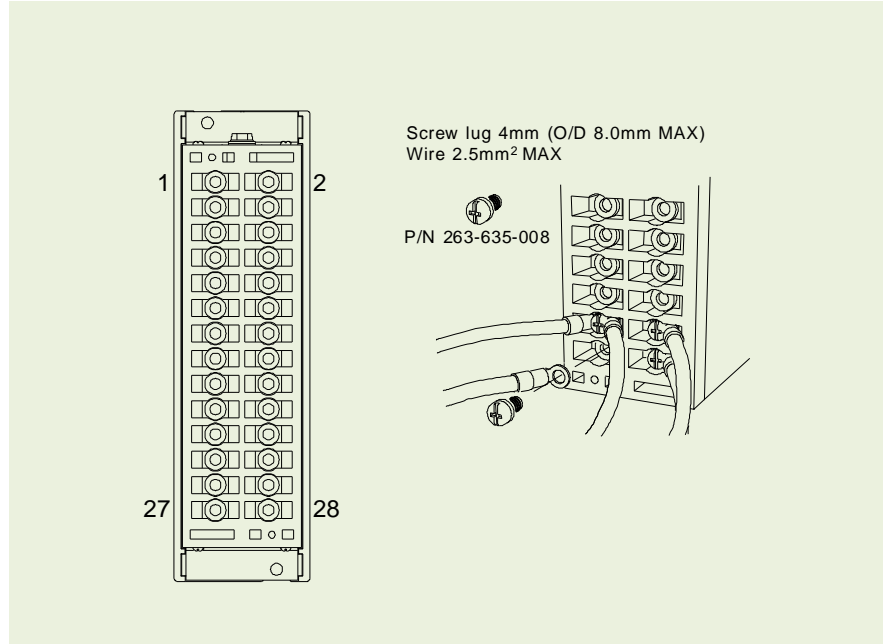

Panel Cut-out

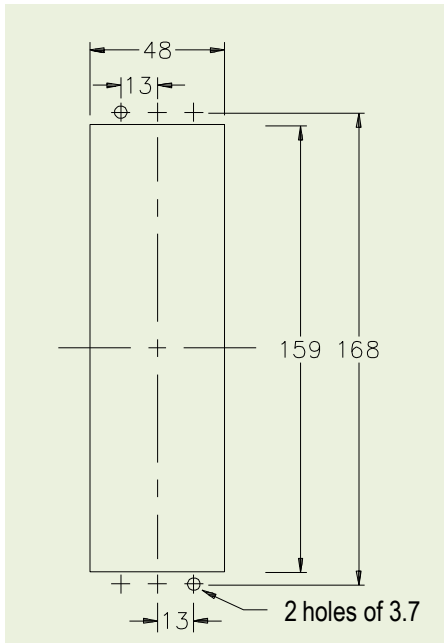

Side View

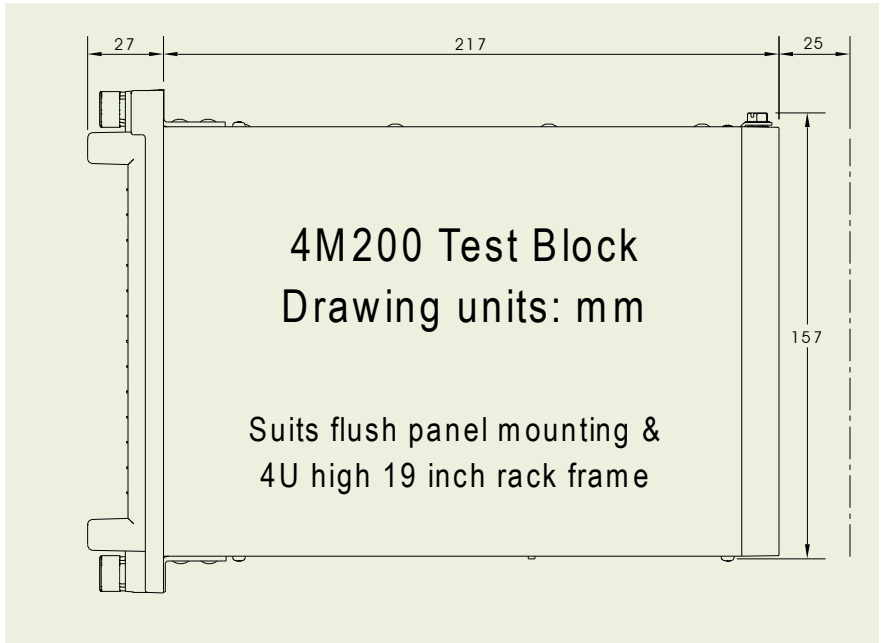

ELECTRICAL ENVIRONMENT

Voltage Rating

Standard	IEC 60255-27,
Test Identification	Test specification
Pollution degree	2
Overtoltage category	III
Rated insulation voltage	300 V rms or d.c.
System auxiliary voltage	40 V DC minimum

Current Rating

Standard	IEC 60947-7-1
Test Identification	Test specification
Rated Wire Cross-section	2.5 mm ²
Current withstand	Continuous withstand: 20 A
	Short-time withstand: 400 A for 1 s

Clearances and Creepage Distances

Standard	IEC 60255-27, #10.6.3, Table C.6
Test Identification	Test specification
Creepage distance	3.0 mm
Clearance	3.0 mm
Clearances and Creepage Compliance	CAD drawings assessment

Safety-related Electrical Tests

Standard	IEC 60255-27, #10.6.4
Test Identification	Test specification
Between any contact pair & either adjacent contact pair	5 kV 1.2/50 μ s 0.5 J 3 impulses of each polarity 2.2 kV ac rms for 1 minute
Between any terminal and the case earth	5.0 kV ac rms for 1 minute
Between any alternate contact pair, provided that the intermediate pair is not used	5.0 kV ac rms for 1 minute
Across Open Contacts of Auxiliary Power Supply Circuit (No Shorting pin)	1 kV ac rms for 1 minute

4M200 with 4M220 Fitted

Standard	IEC 60255-27, #10.6.4
Test Identification	Test specification
Between any contact pair & either adjacent contact pair	5 kV 1.2/50 μ s 0.5 J 3 impulses of each polarity 2.2 kV ac rms for 1 minute
Between Incoming & Outgoing contacts	2.2 kV ac rms for 1 minute
Between any terminal and the case earth	5.0 kV ac rms for 1 minute

Electrical Environment and Flammability

Standard	IEC 60255-27, #10.6.5
Test Identification	Test specification
Single-fault condition	Assessment for CT input circuits
Maximum temperature of accessible parts at ambient temperature +40°C	Metal parts: < 70°C
	Non-metallic parts: < 80°C
Flammability of insulating materials, components and fire enclosures	Assessment

Performance Requirements

Standard	IEC 60947-7-1, #7.2.
Test Identification	Test specification
Temperature Rise	< 45 K
Voltage Drop at 2.4 A DC	< 1.6 mV per tier on each individual clamping

ATMOSPHERIC ENVIRONMENT

Temperature

Standard	IEC 60068-2-1, IEC 60068-2-2	
Test Identification	Test specification	Auxiliary power Supply voltage
Operating Range	-10 to +55°C	Min and Max
Storage Range	-25 to +70°C	Non-energized
Test duration	16 hours at top and bottom temperatures	

Damp Heat (Humidity)

Standard	IEC 680068-2-78	
Test Identification	Test specification	
Operating Range	40°C and 93% RH non condensing	
Test duration	16 hours	

IP Rating

Standard	IEC 60529	
Test Identification	Test specification	
Installed	IP5x	

Performance Standard

Low-voltage switchgear and control gear

Part 7.1: Ancillary equipment – Terminal blocks for copper conductors

Standard	IEC 60947-7-1
----------	---------------

MECHANICAL ENVIRONMENT

Vibration - Sinusoidal

Standard	IEC 60255-21-1 Class 1	
Test Identification	Test specification	Variation
Vibration Response in each of 3 axes	0.035 mm/0.5 gn peak 1 sweep cycle 10-150 Hz	≤5%
Vibration Endurance in each of 3 axes	1.0 gn peak 20 sweep cycles 10-150 Hz	Non-energized

Shock and Bump

Standard	IEC 60255-21-2 Class 1	
Test Identification	Test specification	Variation
Shock Response in each of 3 axes	5 gn, 11 ms, 3 pulses in each direction	≤5%
Shock Withstand in each of 3 axes	15 gn, 11 ms, 3 pulses in each direction	Non-energized
Bump Test in each of 3 axes	10 gn, 16 ms, 1000 bumps in each direction	Non-energized

Seismic

Standard	IEC 60255-21-3 Class 2	
Test Identification	Test specification	Variation
Seismic Response Horizontal, on each axis	7.5 mm/2.0 gn, 1 sweep cycle 1-35Hz	≤5%
Seismic Response Vertical	3.5 mm/1.0 gn, 1 sweep cycle 1-35Hz	≤5%

Mechanical Classification

Durability	10 ³ insertions of the Test Plug
------------	---

4M220 Multi Finger Test Plug

28 test sockets suitable for 4mm shrouded banana plugs.

Securing screws are integrated to retain the Test Plug during testing operations.

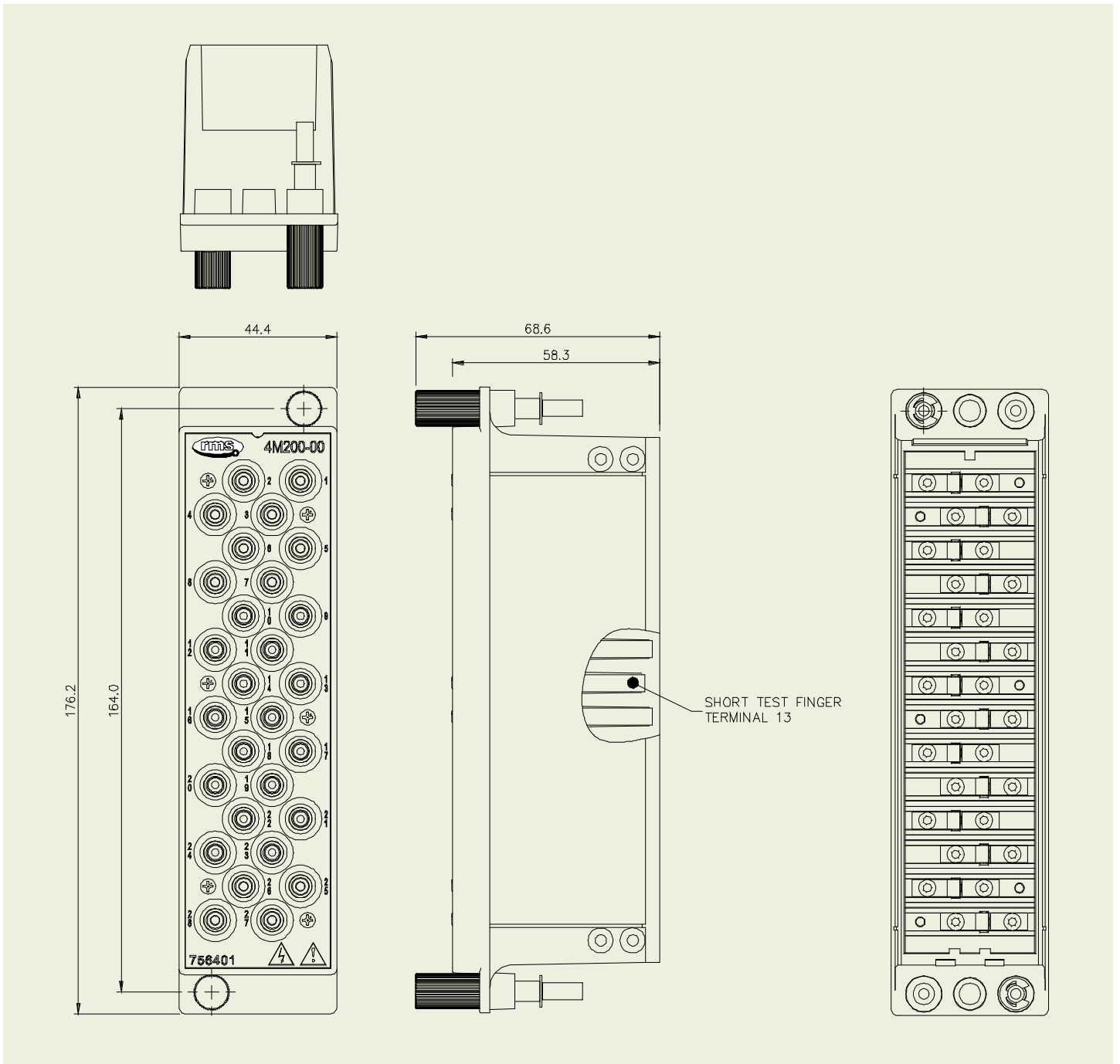

Shrouded Test Leads

Two types of shrouded 'finger safe' test leads are available:

Part Number	Description	Quantity supplied per 4M220
310-230-075-1	Two ended test lead - 75mm	3
310-230-180-1	Two ended test lead - 180mm	3

Wire type: 2.5mm² multi-strand wire with PVC insulation

Test Lead Plugs

Two types of shrouded plug are employed on each test lead as depicted in figure 10 and 11.

Single Plug

The single plug is the most compact & may be plugged into any test socket.

Dual Plug

The dual or 'piggy back' plug is larger & should be plugged into the test sockets on the outside edge of the 4M220. The lead emerging from the dual plug should face out from centre of the 4M220 to ensure adequate clearance for other plugs.

Connecting Multiple Test Leads

Test leads may be linked in a daisy chain arrangement to perform manual CT shorting as described on page 2. Three (3) leads are required to short a group of four (4) CT circuits as follows:

1. Connect the first lead between sockets 21-23
2. Connect the second lead between sockets 25-27
3. Connect the third lead to link the dual plugs in sockets 21-25

An additional lead may be fitted into the third lead dual plug for a ground connection where required.

4M210 Single Finger Test Plug

The 4M210 may be used to probe an individual test circuit. For example, a current metering device may be connected across the 4M210 test sockets and the test plug inserted into a 4M200 CT test circuit so that the current in the CT may be measured.

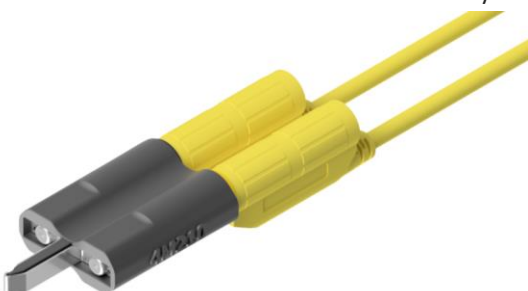

Figure 9: Single finger test plug with test leads fitted

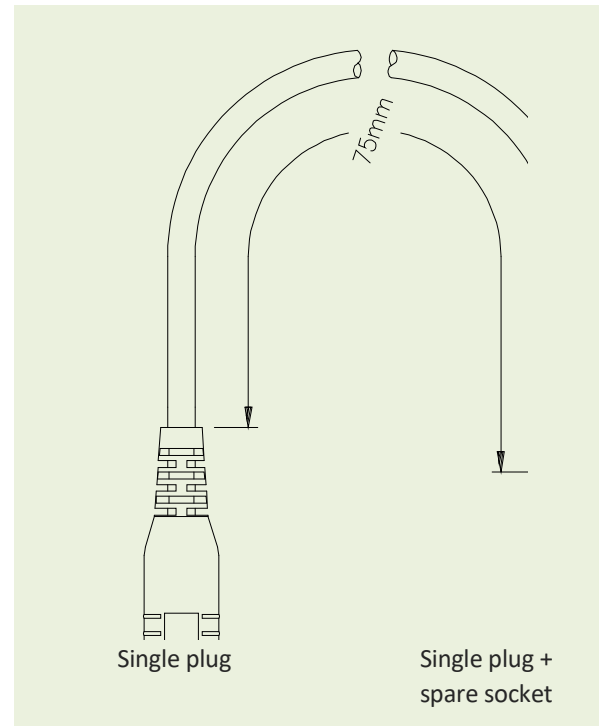

Figure 10: Two ended test lead – short - P/N 310-230-075-1

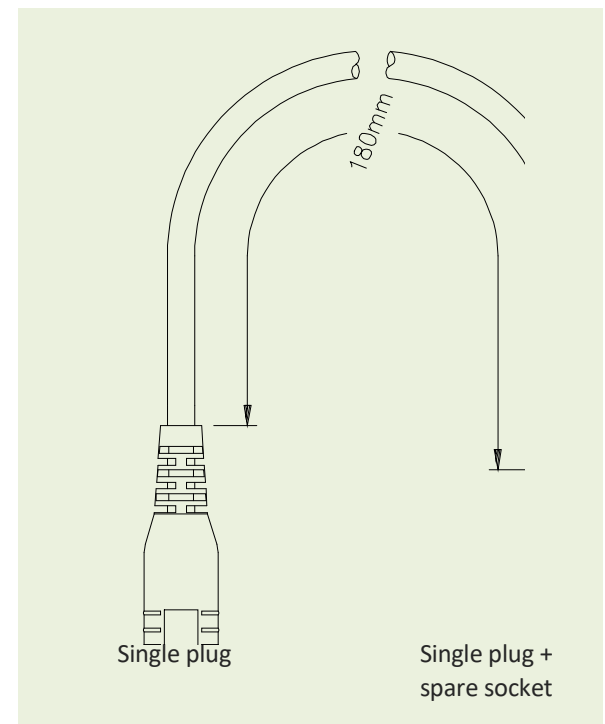

Figure 11: Two ended test lead – Long - P/N 310-230-180-1

4M200 Test Block Order Code

Generate the required ordering code as follows: e.g. 4M200-02

4M200 - <input type="text"/>	
01	Vx isolation 13-14
02	Vx isolation not required
06	Vx isolation 13-14, CT's 21-23-25-27, non-polarized
07	No Vx isolation, CT's 21-23-25-27, non-polarized
08	CT's 1-3, 5-7, 9-11, 15-17, non-polarized
09	CT's 1-3-5-7, 9-11, 17-19, 21-23-25-27, non-polarized
P6	Vx isolation 13-14, CT's 21-23-25-27, polarized
P7	No Vx isolation, CT's 21-23-25-27, polarized
P8	CT's 1-3, 5-7, 9-11, 15-17, polarized
P9	CT's 1-3-5-7, 9-11, 17-19, 21-23-25-27, polarized

4M210 Single Finger Test Plug

The order code for the single finger test plug is 4M210

4M220 Test Plug Order Code

Generate the required ordering code as follows: e.g. 4M220-00

4M220 - <input type="text"/>		
CT Shorting Links	00	External links to be fitted by operator – Must be Fitted Manually by Tester
	P7	Internal links fitted between contacts 21-23-25-27, polarized
	P8	Internal links fitted between contacts 1-3, 5-7, 9-11, 15-17, polarized
	P9	Internal links fitted between contacts 1-3-5-7, 9-11, 17-19, 21-23-25-27, polarized

Cross Reference Charts

> Non-polarized Test Blocks

		RMS Codes
MMLG-01	2RMLG-01	4M200-01
MMLG-02	2RMLG-02	4M200-02
-	-	4M200-06
-	-	4M200-07
-	-	4M200-08
-	-	4M200-09

> Non-polarized Test Plugs

		RMS Code
MMLB-01	2RMLB-S1	4M220-00

> Polarized Test Blocks

		RMS Codes
-	2RMLG-07	4M200-P7
-	2RMLG-08	4M200-P8
-	2RMLG-09	4M200-P9

> Polarized Test Plugs

		RMS Codes
MMLB-07	2RMLB-S7	4M220-P7
-	2RMLB-S8	4M220-P8
-	2RMLB-S9	4M220-P9



RMS Mors Smitt
A Wabtec company

www.rmspl.com.au



Relay Monitoring Systems Pty Ltd design, manufacture and market a wide range of electrical protection and control products for application on high voltage power systems. The company's depth of manufacturing and engineering expertise is backed up by many years of experience since the formation of its predecessor, Relays Pty Ltd (RPL), in 1955. This experience combined with a broad base of field proven product types enables RMS to service specific customer needs by producing relays on demand and with typically short lead times.

Relay Monitoring Systems Pty Ltd

6 Anzed Court
Mulgrave, Victoria 3170
AUSTRALIA
Ph: +61 3 8544 1200
Fax +61 3 8544 1201
Sales: rms@rmspl.com.au
www.rmspl.com.au
www.relays.com.au

ISO9001 Quality Accreditation

RMS holds BSI (British Standards Institution) registration number FS 604860 for the certification of a quality system to AS/NZS ISO9001:2008.

Due to RMS continuous product improvement policy the information contained in this document is subject to change without prior notice.

© 2019 Relay Monitoring Systems Pty Ltd

ABN 76 052 484 483