



HVA28 | HVA34-1 | HVA45 and corresponding TD models HVA68TD

High Voltage test system

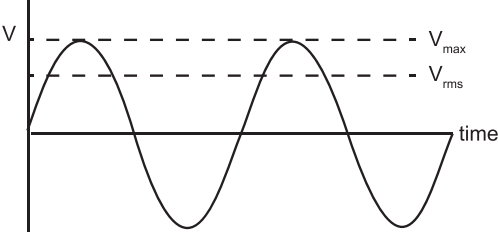

Table of Contents

| | | |
|-----------|---|-----------|
| 1 | Introduction | 5 |
| 1.1 | Regarding this document | 5 |
| 1.2 | Designated use | 6 |
| 1.3 | Operator qualifications | 7 |
| 1.4 | Legal considerations | 7 |
| 1.5 | Technical support | 7 |
| 2 | Safety instructions | 8 |
| 2.1 | Safety rules for HV testing | 8 |
| 2.2 | Safe equipment setup | 8 |
| 3 | About the smartVLF® series | 9 |
| 3.1 | Key applications | 9 |
| 3.2 | Product features | 9 |
| 3.3 | Technical specifications | 11 |
| 3.4 | Expanding to further measurement capabilities | 11 |
| 4 | Setup & operating the smartVLF® series | 12 |
| 4.1 | Device interface | 12 |
| 4.2 | Test set settings | 17 |
| 5 | Application | 23 |
| 5.1 | HVA68TD test lead | 24 |
| 5.2 | VLF Withstand Test & DC Test | 26 |
| 5.3 | TD Diagnostics & Monitored Withstand Test | 28 |
| 5.4 | TD Diagnostics & Monitored Withstand Test and Guard on Near End | 30 |
| 5.5 | TD Diagnostics & Monitored Withstand Test and Guard on Near and Far End | 32 |
| 5.6 | Sheath Test | 34 |
| 5.7 | Vacuum Bottle Test | 36 |
| 6 | Test procedure | 38 |
| 6.1 | Test modes overview | 38 |
| 6.2 | Manual mode overview | 39 |
| 6.2.1 | Setting report details for a manual test mode | 40 |
| 6.2.2 | Characteristics of different output modes | 41 |
| 6.2.3 | Manual test parameters | 43 |
| 6.2.4 | Running a manual test | 45 |
| 6.2.5 | Test summary - test successful | 47 |
| 6.2.6 | Test summary - test failed | 47 |
| 6.3 | Running an auto test - overview | 48 |
| 6.3.1 | Running an auto test - last used sequence | 49 |
| 6.3.2 | Running an auto test - select a sequence from the list | 51 |
| 6.4 | Creating an auto test sequence - overview | 53 |
| 6.4.1 | Configuring a new auto test sequence | 54 |
| 6.4.2 | Modifying an existing auto test sequence | 58 |
| 6.5 | Interrupting a test | 61 |
| 6.6 | Discharge status | 62 |
| 7 | Reporting | 63 |
| 7.1 | Report types | 63 |
| 7.2 | Report parameters | 64 |
| 7.3 | Test report examples | 68 |
| 7.4 | Report management | 70 |
| 8 | Disconnection procedure | 76 |
| 9 | PC software | 78 |
| 10 | Additional information | 79 |
| 10.1 | Storage | 79 |
| 10.2 | Apparatus care | 79 |
| 10.3 | Behavior at different unexpected conditions | 79 |
| 10.4 | Disposal | 80 |

Abbreviations and Glossary

List of terms used in the smartVLF® user manual, sorted alphabetically:

| Term | Meaning |
|-----------------------------|--|
| APL | Arc Pre-Location If the test results in an arc, this function can pre-locate arcs in the DUT's insulation while testing. The APL function is only available on the HVA68TD and constantly monitors for arcing during operation. |
| Arc | Self-maintained gas conduction for which most of the charge carriers are electrons supplied by primary-electron emission. (Source: IEC) |
| Auto frequency | Mode that automatically selects a frequency as close as possible to 0.1 Hz depending on the connected load. |
| DUT | Device Under Test |
| HV | High Voltage |
| MWT | Monitored Withstand Test |
| Propagation velocity | Speed at which an electrical signal can propagate through the cable given in [m/μs]. The propagation speed depends mainly on the used insulation material of the cable. |
| RMS value | Root mean square voltage of sine wave voltages. $V_{rms} = V_{max} / \sqrt{2}$ |
| |  |
| Sample | Applies to Tan Delta measurements only and defines test duration. Each valid measurement value is one sample. In general, you get one sample per period (0.10 Hz → 10 s is one period). |
| SCF | Signal Confidence Factor Each arc creates a unique signal from which the APL calculates the distance to the arc. The SCF is a measure of how accurately the APL can calculate the distance from this signal. On the device, APL requires at least a SCF higher than 2 to pre-locate arcs. A SCF higher than 4 can be considered as high confidence and provides meaningful results. |
| Sequence | Test consisting of up to 15 test steps. |
| TD | Tangent Delta / Tan Delta |
| to short | Forcing the electric potential differences between two or more conductive parts to be equal to or close to zero (infinite current flows in a short circuit). |
| to trip | to stop, if an arc occurs |
| VLF | Very low frequency 0.1 to 0.01 Hz range |
| Withstand Test | Test in which a voltage of a predetermined magnitude is applied for a predetermined time duration. |

1 Introduction

Purpose

This user manual provides information on the proper and safe use of the HVA test set, a member of the smartVLF® series. It contains important safety rules for working with this product and gets you familiar with operating this product. Following the instructions in this document will help you to prevent danger, repair costs, and avoid possible down time due to incorrect operation.

1.1 Regarding this document

This user manual applies to the corresponding VLF high voltage test sets: HVA28, HVA28TD, HVA34-1, HVA34TD-1, HVA45, HVA45TD and HVA68TD.

Safety first



NOTICE

While working with the HVA test set, it is essential to always keep this document and the related Safety Instructions for the HVA Series (b2 article Nr. DHV1440) at hand. Proceed with the measurement only if all safety precautions, applicable normative and relevant safety regulations are obeyed.

Documentation conventions

Safety colors and safety signs mentioned in this document are used in accordance with the International Organization for Standardization technical standard ISO 3864-2; symbol definitions in accordance with ISO 17724. All safety signs and their referents are used in accordance with ISO 7010.

Hazard Severity Panels

Hazard severity panels mentioned in this document are used in accordance with the International Organization for Standardization technical standard ISO 3864-2. They are rectangular in shape and contain the following elements: the general warning sign, the hazard severity panel color and the signal word (which is however optional). Signal words appear in upper case and bold fonts.

- **High level of risk**

Red background with a white contrast color and a warning sign.

Danger label: Indicates a hazardous situation that, if not avoided, will result in death or serious injury.

- **Medium level of risk**

Orange background with a black contrast color and a warning sign.

Warning label: Indicates a hazardous situation that, if not avoided, could result in death or serious injury.

- **Low level of risk**

Yellow background with a black contrast color and a warning sign.

Caution label: Indicates a hazardous situation that, if not avoided, could result in minor or moderate injury.

Signal Word Definitions

DANGER

Indicates a hazardous situation which, if not avoided, will result in death or serious injury.

WARNING

Indicates a hazardous situation which, if not avoided, could result in death or serious injury.

CAUTION

Indicates a hazardous situation which, if not avoided, could result in minor or moderate injury.

NOTICE

Indicates information considered important but not hazard related.

Safety signs and their referents



Warning sign
 Hazard: Electricity
 Human behavior intended: Taking care to avoid coming into contact with electricity.



Prohibition sign
 Hazard: Risk to people specified by the supplementary sign.
 Human behavior intended: Not doing an action specified by the supplementary sign.



Mandatory action sign
 Hazard: Risk to people not following the mandatory action specified by the supplementary sign.
 Human behavior intended: Carrying out mandatory action specified by supplementary sign.

1.2 Designated use

HVA test sets of the smartVLF® series are designed to perform routine and diagnostic high voltage insulation testing of various types of highly capacitive loads during manufacturing, commissioning, and maintenance. The various, partly automated, tests can be defined and parametrized via the user interface at the device's front panel or via an externally connected PC or laptop.

Appropriate devices under test (DUTs)

Cables:

- Extruded cables (e.g. XLPE)
- Laminated cables (e.g. PILC)
- Insulated cables
- Cable jackets/sheaths

Other capacitive loads:

- Generators
- Switchgear
- Transformers
- Rotating machines
- Insulators
- Bushings



NOTICE

Other devices:
 Before proceeding, contact b2 electronics to validate appropriate use.

Appropriate high voltage tests

- VLF withstand test
- VLF Tan Delta test (for devices with integrated Tan Delta diagnostics capabilities)
- Monitored withstand test (for devices with integrated Tan Delta diagnostics capabilities)
- DC test
- Vacuum bottle test
- Sheath test
- Sheath fault location

Further measurement possibilities

- Capacitance
- Resistance
- Dielectric breakdown voltage
- RMS current
- Applied voltage
- Tan Delta (for devices with integrated Tan Delta diagnostics capabilities)
- Distance to the arc (applies to test sets with APL functionality only)



NOTICE

Should the HVA test set not seem to function properly, do not use it anymore and contact b2 electronics Technical Support right away (see Chapter 1.5 Technical Support for contacts). Only qualified experts at the b2 electronics Repair Center may open the device for inspection, maintenance and repair work.

1.3 Operator qualifications

Working on high voltage assets can be extremely dangerous. Only personnel qualified, skilled, and authorized in electrical engineering are allowed to operate this HVA test set and its accessories! Proof of necessary qualifications for working in the high voltage domain as well as obeying relevant local safety regulations is mandatory.

Before approaching the work, clearly establish the responsibilities.

The supervising operator is responsible for the safety requirements during the whole measurement.

1.4 Legal considerations

Compliance statement

The device is designated in the following statements as "test set", "product", "device", "equipment", or "apparatus".

All appropriate high voltage tests, listed in the chapter 1.2 Designated use, comply with following guides or standards:

- VLF withstand tests with IEEE 400.2; standards DIN VDE 0276-620 (CENELEC HD 620 S2), DIN VDE 0276-621 (CENELEC HD 621 S1);
- AC and sheath testing with IEC 60502-2 / IEC 60229.

They are all implemented in the device software.

Declaration of conformity (EU)

The equipment adheres to the guidelines of the council of the European Community for meeting the requirements of the member states regarding one or a combination of the following directives: Electromagnetic compatibility (EMC) directive; Low voltage directive (LVD); RoHS directive.

Declaration of conformity (UK)

The equipment adheres to the regulations of the UK government for meeting the requirements regarding one or a combination of the following regulations:

- Electromagnetic Compatibility (EMC) Regulation
- Electrical Equipment Regulation (Safety)
- Regulation for Restriction of the Use of Certain Hazardous Substances in Electrical and Electronic Equipment

FCC compliance (USA)

This equipment has been tested and found to comply with the limits for a Class A digital device, pursuant to part 15 of the FCC Rules. These limits are designed to provide reasonable protection against harmful interference when the equipment is operated in a commercial environment. This equipment generates, uses, and can radiate radio frequency energy and, if not installed and used in accordance with the instruction manual, may cause harmful interference to radio communications. Operation of this equipment in a residential area is likely to cause harmful interference in which case the user will be required to correct the interference at his own expense. Changes or modifications not expressly approved by the party responsible for compliance could void the user's authority to operate the equipment. If this equipment does cause harmful interference to radio or television reception, contact b2 Technical Support.

Copyright

© 2024 b2 electronics GmbH

All rights reserved.

No part of this publication may be reproduced, transmitted, stored, or translated in hard copy or electronic form without the written consent of b2 electronics GmbH.

1.5 Technical support

b2 electronics Technical support provides you with following services regarding the b2 products:

- Technical support
- Technical information on repairs
- Basic applications assistance
- Product trainings
- Support at measurement for training purposes

You can reach us at support@b2hv.com or under T +43 59896 3232.

2 Safety instructions

In this chapter, the most important safety instructions for the use of the HVA test set are summarized. Respect all safety information contained in here! If you do not understand some of the safety instructions, contact b2 electronics Technical Support before proceeding (see previous page for contacts).

Before carrying out any high voltage test with an HVA test set, read these Safety Instructions in their entirety. They are at your disposal also in a separate brochure Safety Instructions for the HVA Series (b2 article Nr. DHV1440) where they are available in all EU languages.



NOTICE

Do not operate the HVA test set without understanding the safety information! HVA test set is meant for specific applications only. Use it in a safe manner and sound condition only.

2.1 Safety rules for HV testing



CAUTION

It is mandatory to obey the five safety rules in the following order at all times!

1. Switch out Device Under Test
2. Secure against re-energising
3. Discharge and prove dead
4. Ground and short circuit
5. Cover or close off nearby live parts

You may proceed with the measurement using this HVA test set only if all safety precautions, applicable normative and relevant local safety regulations are obeyed.



WARNING

Please study the equipment setup for the specific HVA test set (placed on the inner flip outs of the Safety Instructions for the HVA Series brochure) in order to set up the equipment in a safe manner!

Establish secure earthing via connection **1**. Follow the "Safe equipment setup" instructions in the chapter 2.2 below to do that in a safe and proper manner.



DANGER

Electric Shock Hazard!

NEVER assume that equipment is safe to handle without using the necessary safety equipment and earthing procedures.

2.2 Safe equipment setup

Prior to starting the measurement, please refer to the equipment setup for the specific HVA test set placed on the inner flip outs of the Safety Instructions and the five safety rules mentioned above under "Caution".

During the dismantling, secure the appliance against being switched on again by pressing the "Emergency OFF" button. Lock the system with the key switch. Remove it and stow the key away to prevent other people from accessing it.

3 About the smartVLF® series

3.1 Key applications

For the devices with integrated Tan Delta diagnostics capabilities the TD test results of the device under test can be easily measured, recorded and displayed on the screen of the test set. The test results can be easily stored via USB flash drive, Bluetooth synchronization or internal memory.

Matching PC software b2 ControlCenter is included in the scope of delivery. With this PC software the test results can be easily stored on a PC or laptop for analysis, trending or quality control. This enables the cable engineer to now make the TD testing a routine maintenance test. Additional benefits include:

Cable testing

All test sets of the smartVLF® series are designed to perform high voltage insulation testing of various types of highly capacitive loads with pure sinusoidal, square or DC output voltage. Appropriate devices under test are cables (extruded, laminated, in other way insulated) or other highly capacitive loads (see Chapter 1.2 Designated use).

Cable diagnostics

HVA28TD, HVA34TD-1, HVA45TD and HVA68TD are VLF test units with integrated Tan Delta measuring system. Such a test set provides a high voltage Tan Delta measuring system suitable for testing medium voltage electrical insulation systems such as cables, capacitors, switchgear, transformers, rotating machines, insulators and bushings. Tan Delta testing enables the cable test engineer to detect insulation defects before the cable fails in service.

Cable fault pre-location

VLF withstand tests are used to detect weaknesses in the cable insulation. While a healthy cable is passing the voltage withstand test unharmed, a cable with pre-damaged insulation will break down during this test, resulting in an arc.

The HVA68TD test set is equipped with the Arc Pre-Location function (APL). When a breakdown occurs during testing, the APL function calculates the distance to the arc position. This helps to save time and cost in the subsequent cable fault location process. Please consider that the APL function is a pre-location method and cannot replace a full cable fault location process.

3.2 Product features

To assure that the workplace is safe and that operators can fulfil their responsibilities with ease, the HVA provides the following features:





| | Feature | Purpose | Advantage |
|---------|---|--|--|
| Testing | Built-in memory | <ul style="list-style-type: none"> To save test sequences To save test reports | Facilitates documentation and subsequent test repetition |
| | Comprehensive reporting | To document your measurement results automatically | Saves the user an extra step |
| | Fully automatic test sequences | To test according to IEEE or other standards | <ul style="list-style-type: none"> Facilitates complex testing Facilitates test repetition |
| | Integrated TD | Proven, simple and reliable test method for obtaining diagnostics values from the insulation of the DUT (HV cable) | <ul style="list-style-type: none"> Enables the user to do MWT tests Makes TD test to a routine maintenance test (Remark: Possible with symmetrical sine only.) |
| | Load-independent output | To display true symmetrical sine and square waveforms | Facilitates testing |
| | Optimized frequency selection / automatic load measurement | <ul style="list-style-type: none"> To test capacitive loads No equipment exchange needed No changes in settings necessary | <ul style="list-style-type: none"> Facilitates testing Limits number of connections to the DUT |
| | Real time display | To instantly indicate output voltage | Facilitates testing |
| | Unlimited operation (Duty cycle) | Operating time is within the specifications | Continuous operation |

| | Feature | Purpose | Advantage |
|------------------------|---|---|---|
| Safety | Discharge status indication | The red LED ⁷¹ flashes if the measured voltage at the output is higher than 100 V | Improves safety during normal disconnection procedures |
| | Fully integrated discharge and transient circuit | <ul style="list-style-type: none"> To ground the DUT after testing as it avoids self-recharging of the DUT To protect the device from transient over-voltages | <ul style="list-style-type: none"> Improves safety Protects the test set |
| | Initial load balance at reduced voltages | To check automatically for shorts or grounds, during load measurement, before test initiation | Improves safety |
| | Instrument lock - key switch | To prevent unauthorized use | Locks the device and protects the operator as well as the device itself |
| | Local and optionally available remote Emergency OFF switches | To shut down operations in emergency situation | Improves safety |
| | Return voltage indication | To monitor external high voltage greater than 100 V (AC) | Improves safety |
| Smart benefits | APL* | <ul style="list-style-type: none"> Pre-locates arcs in the DUT's insulation Returns distance values if an arc occurred | <ul style="list-style-type: none"> Monitors constantly for arcing during operation Pre-location adds additional value to traditional VLF testing Saves time and costs in the subsequent cable fault location process |
| | Arc management | <ul style="list-style-type: none"> To provide short-circuit protection To allow fault conditioning | It is up to the user, if the fault should be conditioned or the system trips / test stops. |
| | Bluetooth | <ul style="list-style-type: none"> To send test reports To upload test sequences | <ul style="list-style-type: none"> Facilitates documentation Facilitates test repetition |
| | Dual Discharge Device (DDD) | Unique feature of HVA test sets. Two independent discharge devices - one electronic and one mechanical | Enhanced safety for the user in regard to the device |
| | Hinged lid* | Provides additional storage surface and space during the measurement. | <ul style="list-style-type: none"> Practical platform for placing the notebook during work 180° rotatable |
| | IP67** (with closed lid) | <ul style="list-style-type: none"> To avoid damage during transport/storage No additional transport boxes necessary | Watertight and very rugged case that protects instrument and improves functionality |
| | Maintenance-free design | To avoid moving parts and need for lubrication | <ul style="list-style-type: none"> Reduces maintenance Improves instrument durability & reliability |
| | Multi-purpose HV test lead* | Depending on the test purpose, the adapters can be easily exchanged | A single HV test lead with two DUT adapters for VLF withstand test, TD diagnostics and PD diagnostics |
| | Portable and lightweight | Lightest and most powerful devices in their voltage range | Widely applicable for field use and on-site testing |
| USB flash drive | <ul style="list-style-type: none"> To store and share unlimited number of test reports To upload test sequences | <ul style="list-style-type: none"> Facilitates documentation Facilitates test repetition | |

* only available for the HVA68TD test set

** applies only to HVA28, HVA34-1, HVA45 test sets and their corresponding TD derivatives

3.3 Technical specifications

| Test Set | Output voltage | Output load | Weight |
|---|---|--|------------------|
| HVA28 & HVA28TD  | max. 29 kV _{peak} , 21 kV _{rms} | 0.5 μF @ 0.1 Hz @ 20 kV _{rms} | 14 kg / 31 lbs. |
| HVA34-1 & HVA34TD-1  | max. 34 kV _{peak} , 24 kV _{rms} | 1.5 μF @ 0.1 Hz @ 24 kV _{rms} | 39 kg / 86 lbs. |
| HVA45 & HVA45TD  | max. 45 kV _{peak} , 32.3 kV _{rms} +4 kV option: max. 49 kV _{peak} , 34.6 kV _{rms} | 0.9 μF @ 0.1 Hz @ 32.3 kV _{rms} | 39 kg / 86 lbs. |
| HVA68TD  | max. 68 kV _{peak} , 48 kV _{rms} | 2.0 μF @ 0.1 Hz @ 44 kV _{rms} | 63 kg / 139 lbs. |

For more detailed information on the devices, please go to <https://b2hv.com/products/hva-series>.

3.4 Expanding to further measurement capabilities

All smartVLF® systems can be operated in combination with our external PD and PDTD diagnostic systems in order to expand their diagnostics capabilities on partial discharge evaluation. We offer the widest range of solutions on the market, from portable and modular PD instruments up to trailer-mounted systems for all voltage ranges of our HV test sets.

PD diagnostics can be carried out simultaneously with the TD diagnostics. This saves time and prevents pre-conditioning of the cable by the first of two sequential tests. For more information, please go to <https://b2hv.com/products/pdtd-series>.

4 Setup & operating the smartVLF® series

4.1 Device interface

4.1.1 Front panel

All HVA control and connection components are located on the front panel and/or the side panel. There are three device variants in the smartVLF® series. Below is the table with the features of their front panels (and one side panel) followed on the next side by the depiction of the panels.

| Nr. | Name | Description |
|-----|--------------------------------------|--|
| 1 | Earthing connector | Serves as connection point from the HVA to earth. |
| 10 | HV output connector | Serves as connection point from the HVA to the HV test lead. To connect: Unscrew the black protection cap, screw the HV test lead into the HV output connector (until a click can be heard) and tighten. |
| 30 | Power supply socket | Serves as connection point from the HVA to a power source. The specification is given on the corresponding type plate. |
| 31 | Communication port | Serves as connection point from the HVA to a USB flash drive. |
| 40 | HV switch [I/O] button | Activates and deactivates high voltage. To activate HV output: Press within 10 seconds after "Start". To deactivate HV output: Press during HV is activated. |
| 41 | Navigation knob | Enables user to select and confirm options and functions shown on the display. To scroll the selection up or down / left or right: Rotate. To enter the selection: Click (push in). |
| 42 | Emergency OFF button | Activates emergency shut-down. HV operation is only possible, if this button is deactivated. To activate "Emergency OFF": Press in. To deactivate "Emergency OFF": Release latch and rotate. |
| 43 | Key switch [ON/OFF] | Locks the unit to prevent unauthorized use. To disable unit: Remove key from the OFF Position. To reactivate unit: Insert key and turn to ON Position. |
| 44 | Main switch [I/O] | Activates the HVA. This switch is a fuse with integrated magnetic auto-reset 16 A. To reset: Turn the main switch off (O) and then on (I) again. |
| 47 | Remote control interlock plug | Provides interlock for the remote switch (i.e. door interlock), contains red and green signals. Can be connected to a remote "Emergency OFF" switch, a gate, a foot pedal or a dead man switch. |
| 48 | Air vent | Provides cooling of electronic components. |
| 70 | Display screen | Displays menu, options and status information. |
| 71 | Red LED | Indicate HV status on the device. • Green LED on, red LED off: The device is ready, HV is not yet applied to the device. |
| 72 | Green LED | Attention: This is NO indication that DUT is fully discharged or safe. • Green LED on, red LED on: During switch-on process of the HVA to see if LEDs are working. • Green LED off, red LED on: HV is applied, the test starts / is running. • Green LED on, red LED flashing: a) The device is discharging or, b) backfeed voltage is present. HV is not applied but external voltage has been detected. Voltage at HV test lead sensed > 100 V. |

HVA28, HVA28TD - front panel

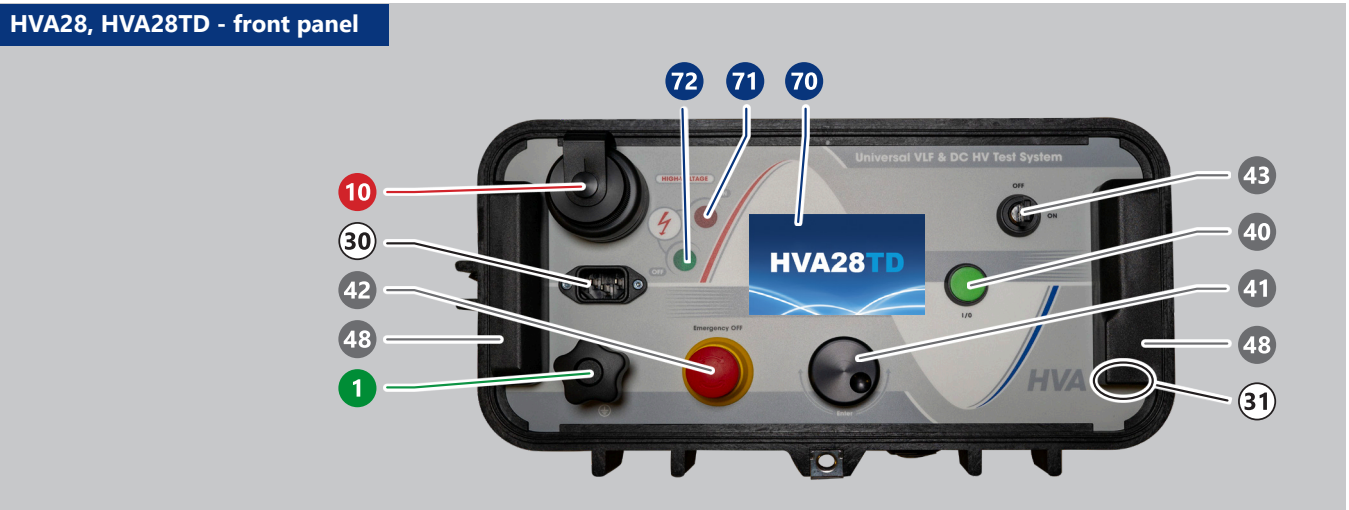

HVA34-1, HVA34TD-1, HVA45, HVA45TD - front panel

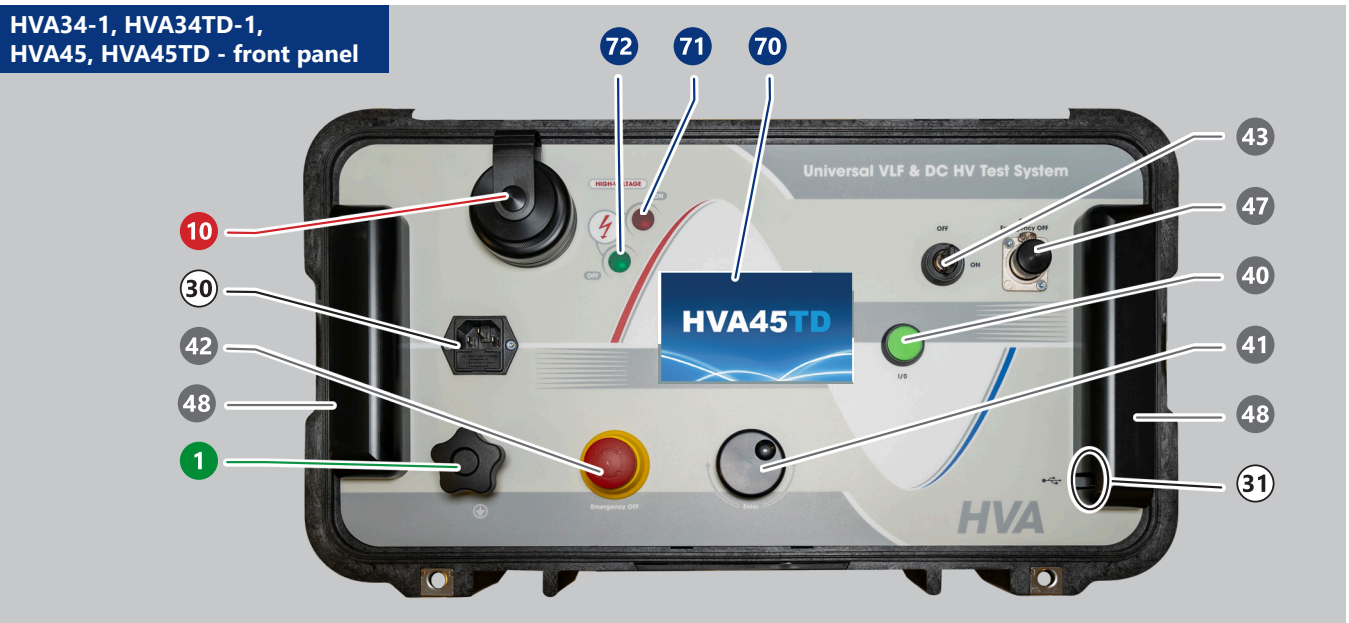

HVA68TD - front panel

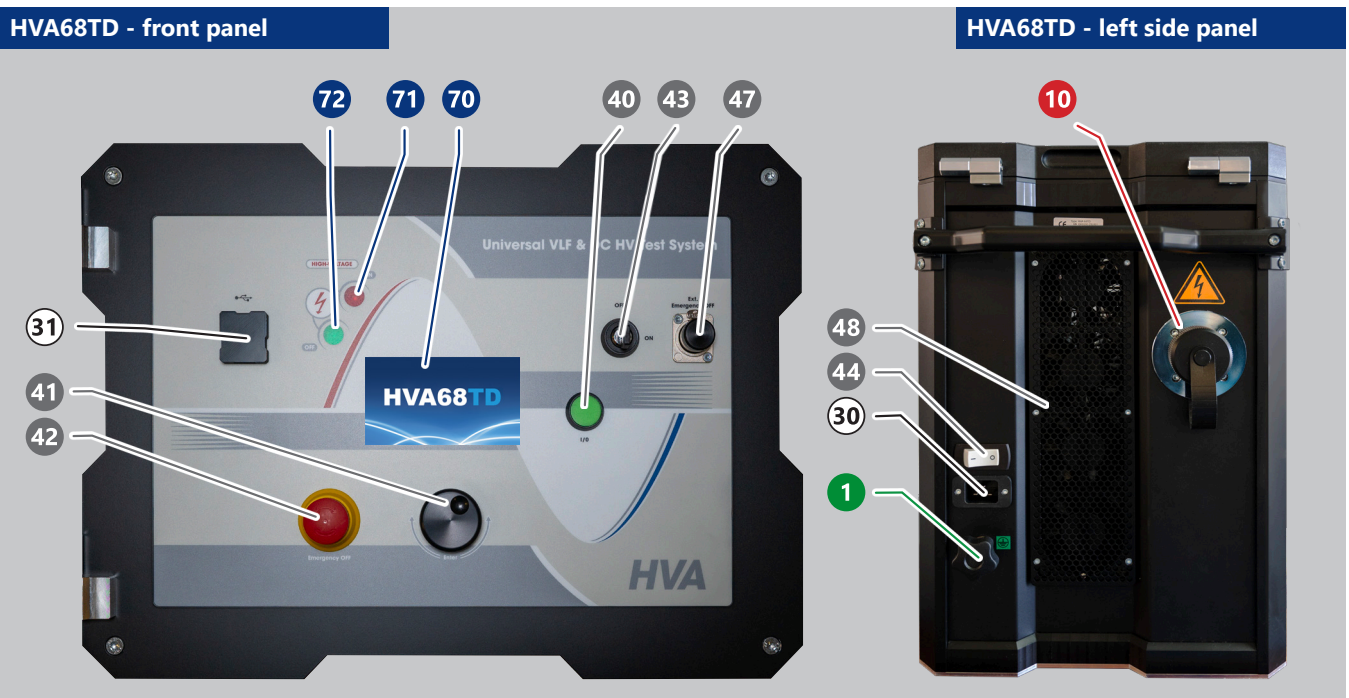

4.1.2 Screen

The display screen is the same for all smartVLF® test sets. The part between the black header and footer areas shows the current procedure. During the preparation of the measurement, the measurement itself and after the measurement, this field adapts to the procedure in progress.

The meaning of the separate elements is as follows:

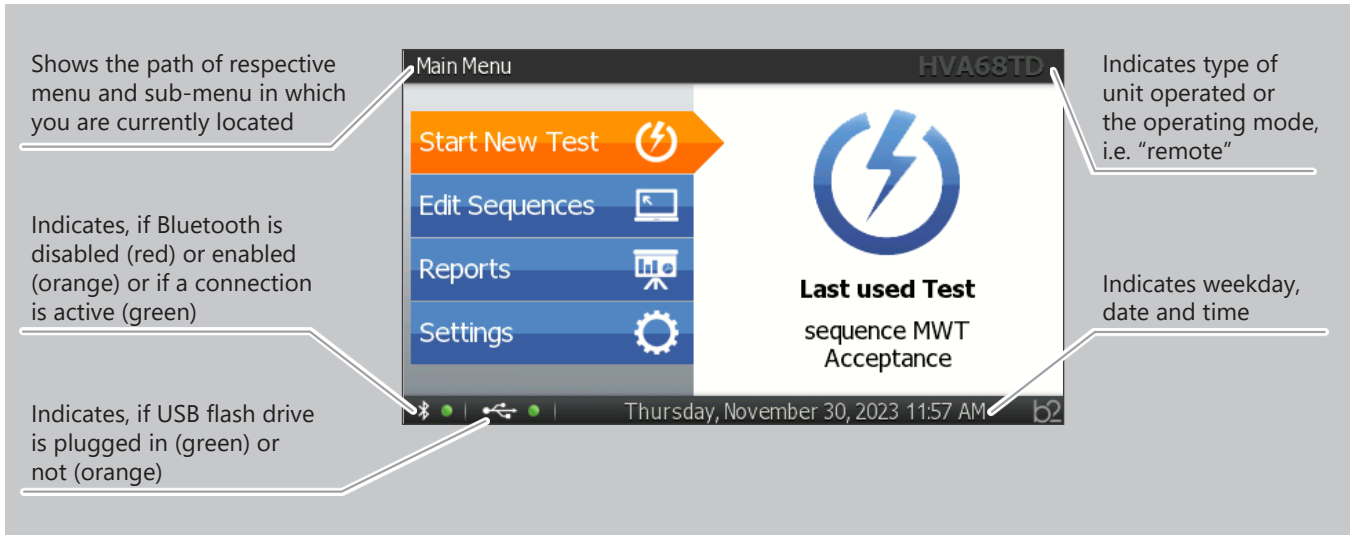

4.1.3 Operating the keyboard

For some steps in the settings for sequences and reports, the operator is required to enter some information via the keyboard. Possible entries are:

- A B C D E F G H I J K L M N O P Q R S T U V W X Y Z (Remark: only the capital letters are available)
- + - "space" . () # @ * / \ ! ? = : , ; ' % ° ^ < > | & []
- 0 1 2 3 4 5 6 7 8 9

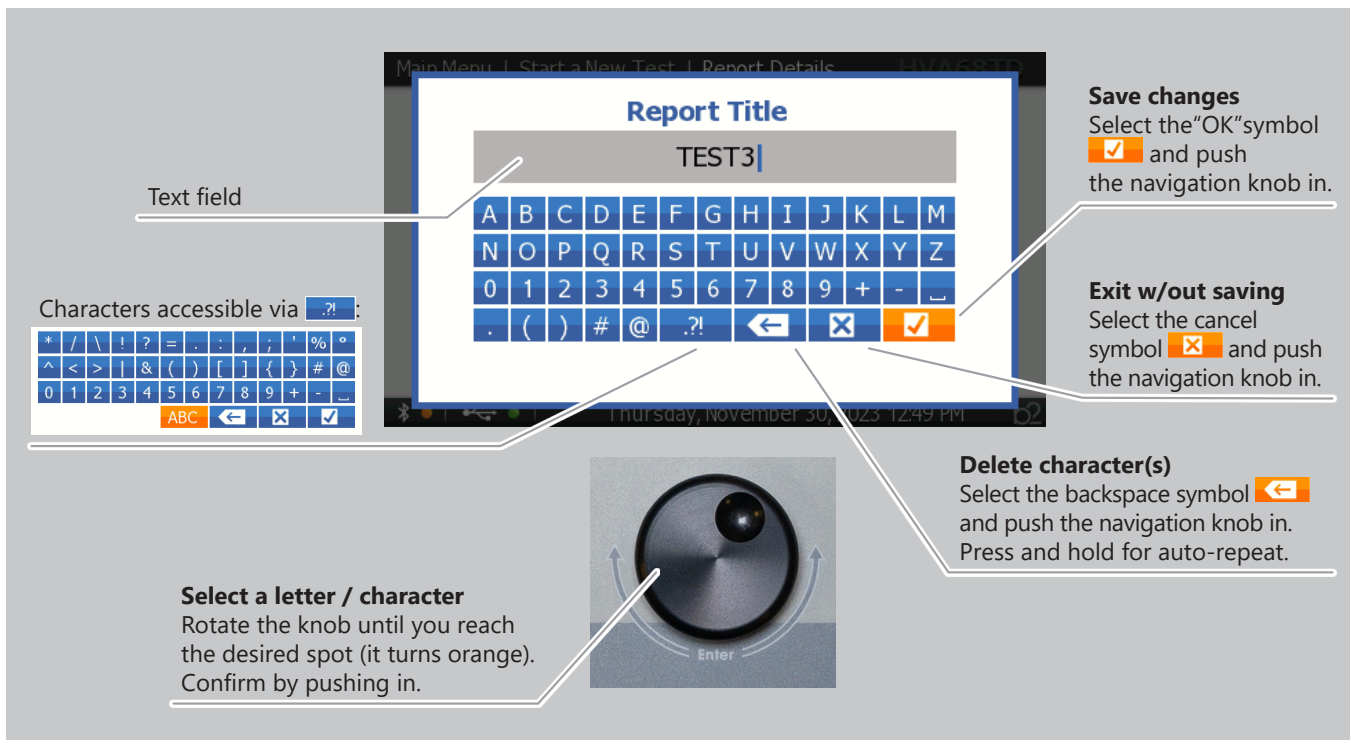

Information and Warning Messages

There will be some situations during the measurement procedures when the test set shows some kind of information or warning message. Below are four examples of such messages with their explanations.

INFORMATION

This screen gives an information. You have only one option here. Press **"OK"** to confirm.

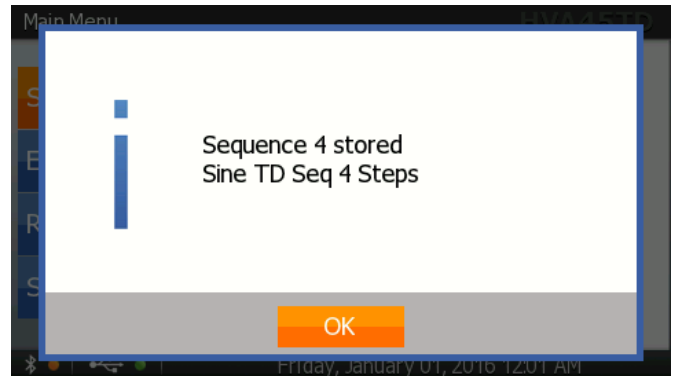

QUESTION

This screen indicates a user interaction/question. Consider the information on the screen and make your choice by selecting **"Yes"** or **"No"**. In some cases, where applicable, an option **"Delete All"** appears, too.

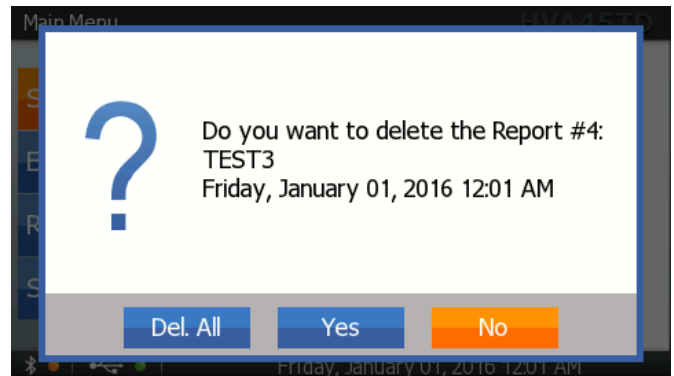

WARNING

This screen shows a warning. You have only one option here. Press **"OK"** to confirm.

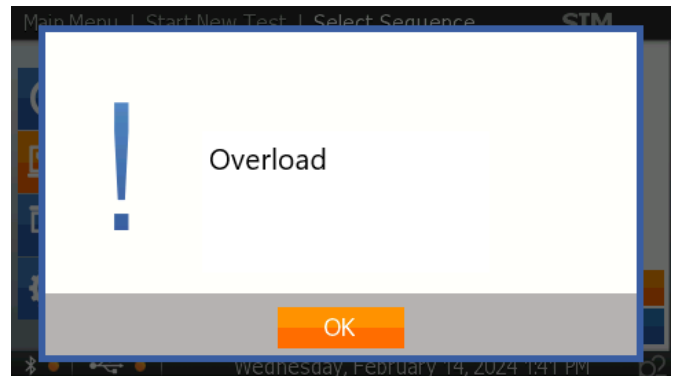

ERROR

This screen indicates an error. The operation in progress could not be finished successfully.

Please consider the information and decide, if further action is necessary. Press **"OK"** to confirm.

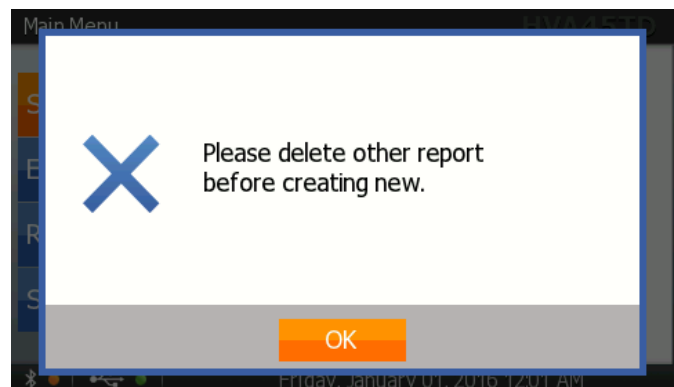

4.1.4 Data transfer modes

The HVA's built-in memory can save up to 50 reports and 50 test sequences. Furthermore, an unlimited number of reports and sequences can be stored when the HVA is connected to the PC software or by using a USB flash drive.

USB configuration:

All reports saved in the HVA memory can be transferred to a USB flash drive. To see the data administration, please go to "Settings" / "Data Administration".

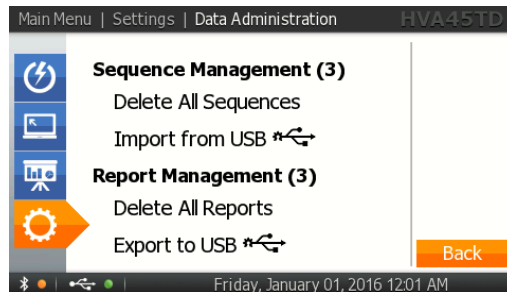

Bluetooth configuration:

If the HVA is connected to the b2 ControlCenter, reports and sequences can be downloaded from the HVA using the corresponding functions. See software manual for further information.

For information on how to access data transfer modes and apply them for Sequence and Report Management, please go to chapter 4.2.4 Data administration.

4.1.5 External interlock

This connector is part of the test sets HVA34-1, HVA34TD-1, HVA45, HVA45TD and HVA68TD and allows to expand the HVA test set with a remote interlock and remote signal lamps for indicating the HV status.

If no external interlock is attached, the "xy" interlock bridge plug needs to be used for operation with HV.

47

Ext.
Emergency OFF

**interlock
plugged in**

Ext.
Emergency OFF

**interlock
open**

Depiction of the connector on the test set.

| | | |
|--------------------|---|--|
| PIN1: Interlock | 1 | |
| PIN2: Interlock | 2 | |
| PIN3: Not in use | 3 | |
| PIN4: Not in use | 4 | |
| PIN5: Lamp HV ON | 5 | |
| PIN6: Lamp HV OFF | 6 | |
| PIN7: Ground (GND) | 7 | |

NOTICE



Check the function of the remote of the switch for mechanical damage before each use!

Equipment not included:

Cables for remote control and external lamps are not in scope of delivery!

Cable requirements:

- Twisted pair; rating: 600 V
- Dimensions: 18 gauge or 1 mm²; recommended cable length: max. 50 m
- 2-pole to 5-pole cable

External lamp requirements:

- Specifications: 12 V, max. 1.2 W
- Recommended colors: red, green

4.2 Test set settings

We advise you to deal with the instrument setup prior to the HVA's first use. Although, settings can be modified anytime. You will find the selection option Instrument Setup in the main menu under "Settings".

Initial display screen

The display screen is the same for all smartVLF® test sets.

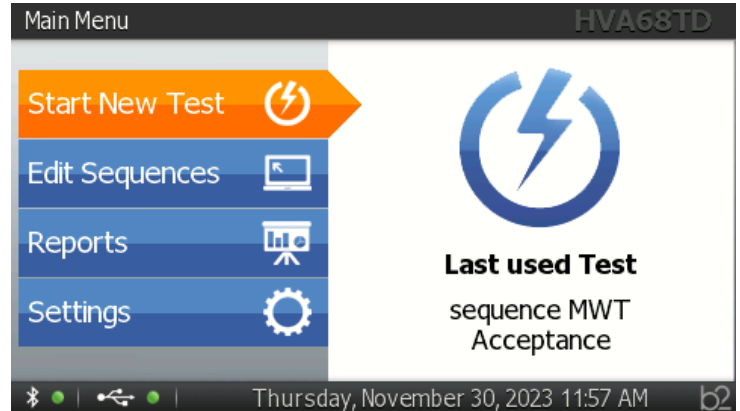

Test set settings

You will find the selection option "Instrument Setup" in the main menu under "Settings". Here you can set the instrument setup, get the information on the connected test set, choose a language and set up the data administration.

Each of these four categories got a separate sub-chapter on the following pages (4.2.1 thru 4.2.4). There, each feature is described in detail.



4.2.1 Instrument setup

IS1: Settings

From the main menu, select "Settings"



IS2: Instrument Setup

Select "Instrument Setup"

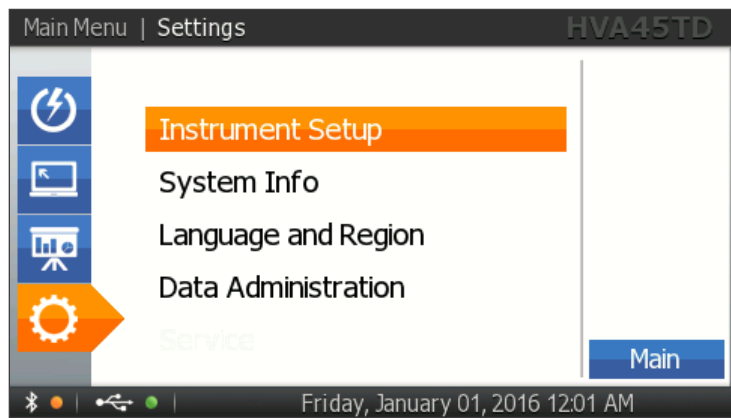

IS3: Set Date and Time

Select "Set Date and Time". This information will be shown on the screen of the test set at all time.
Hours range: 0 to 23
Minutes range: 0 to 59

Remark:
The months are only available by their names and not by the numbers 1 to 12.

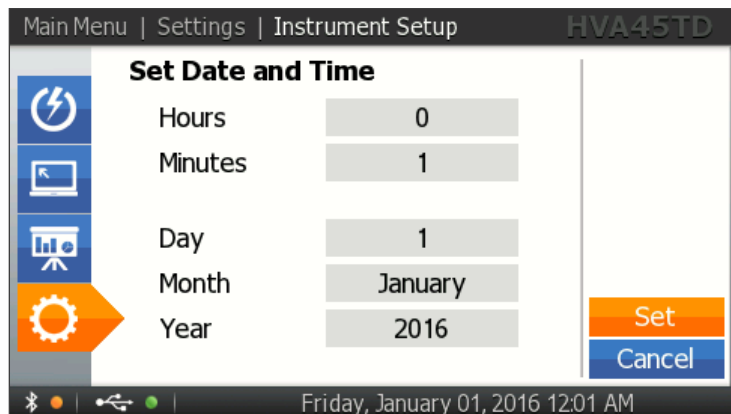
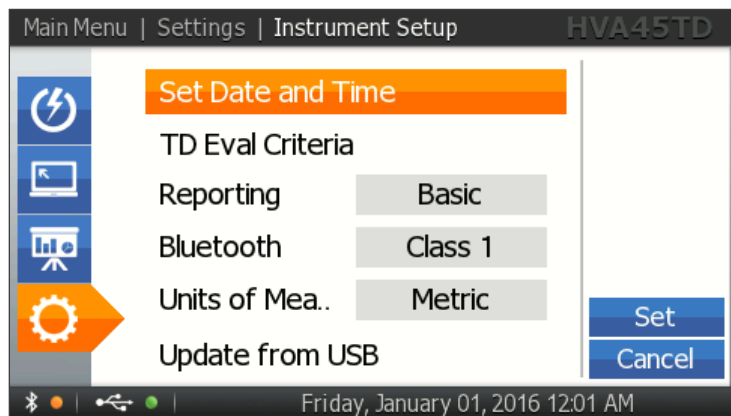

IS4: TD Evaluation Criteria

A table where Tan Delta limits defined in IEEE400.2-13 guide are demonstrated. They are displayed via a traffic light labeling system, depending on the test results.

The data in this table depends on the last used sequence. They cannot be changed, but are rather informative.

| Condition Assessm. | TDTs 1.0U _o [E-3] | DTD [E-3] (1.5U _o - 0.5U _o) | TD 1.0U _o [E-3] |
|--------------------|------------------------------|--|----------------------------|
| No Action Required | < 0.5 | & < 2.5 | & < 10.5 |
| Further Study | 0.5 .. 1.1 | 2.5 .. 5.5 | 10.5 .. 50.5 |
| Action Required | > 1.1 | > 5.5 | > 50.5 |

IS5: Reporting

Reporting types:

- Disabled
- Basic
- Extended

Basic reporting only states the DUT type and a title, whereas **extended reporting** provides detailed information on DUT. Go to chapter 7.2 Reporting parameters for further information.

IS6: Bluetooth

Depending on the Bluetooth setting, the device selects the corresponding RF transmission speed.

Setting types:

- Class 1
- Disabled

IS7: Units of measurement

The options are:

- Metric
- Imperial

When imperial units are selected, the temperature is automatically displayed in °F.

IS8: Update from USB

This function is used when installing updates and for transferring information from the PC software to the unit via USB flash drive.

Remark:
Insert the USB flash drive before selecting this function.

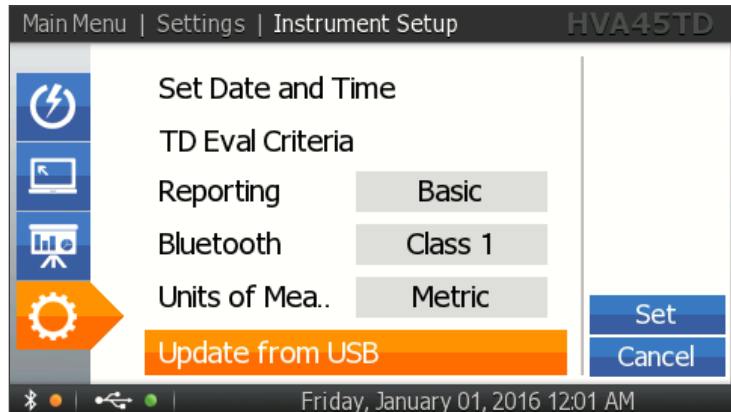
**4.2.2 System information****SI1: Settings**

From the main menu, select "Settings"

**SI2: System Information**

Select "System Info"

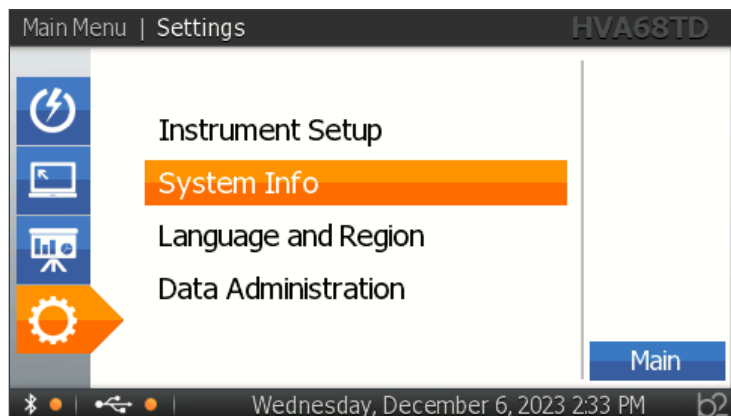
**SI3: System Information**

Information regards the connected test set and cannot be modified by the operator. Mentioned is:

- Firmware version
- Serial number
- Nickname (to alter via PC software)
- Bluetooth MAC address
- USB | APL version
- Date of last calibration
- Device temperature

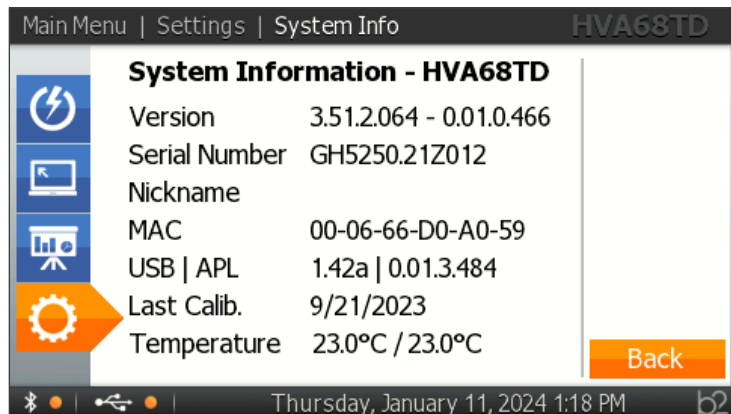

4.2.3 Language and region

L1: Settings

From the main menu, select "Settings"



L2: Language and Region

Select "Language and Region"

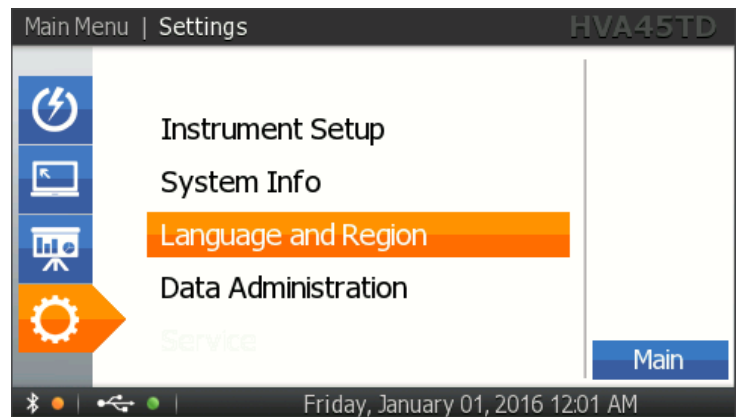

L3: Select a language

The list of available languages is based on the firmware version.

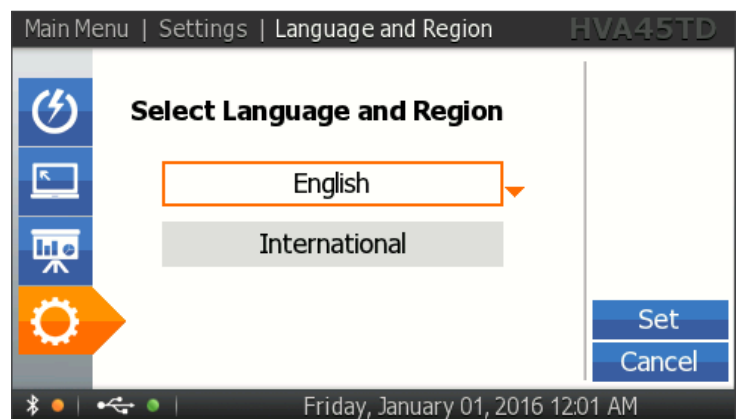

L4: Select a region

The list of available regions is based on the firmware version.

Based on the region setting, the test set selects the corresponding date/time format. "International" region has the date/time format as depicted on the screen shots in this manual.

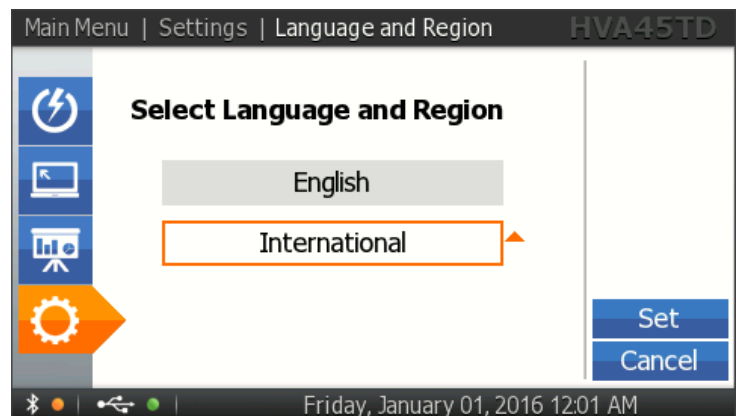

4.2.4 Data administration

DA1: Settings

From the main menu, select "Settings"

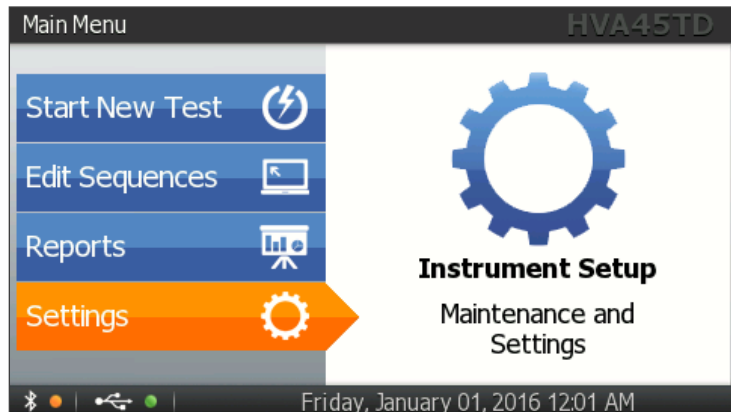

DA2: Data Administration

Select "Data Administration".

Remark:

In order to export or import data via an USB flash drive, you need to insert one into the device. Other USB flash drives are greyed out and unable to operate.

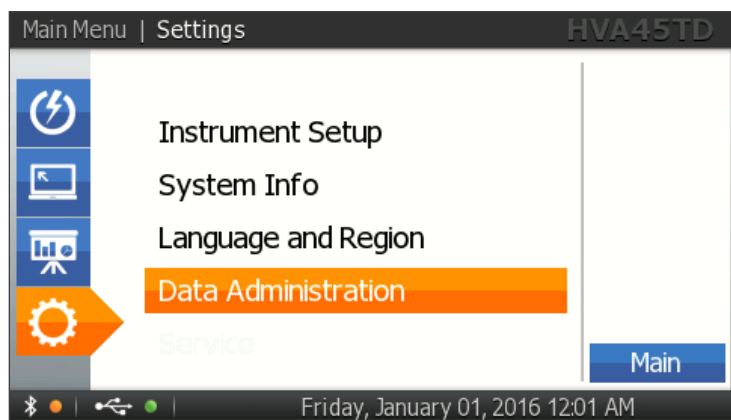

DA3: Sequence Management

In first line, number of available sequences on the test set is given.

You have two options here:

- delete all sequences from the device
- import sequences from USB

Remark:

Accepted sequence format: *.hse

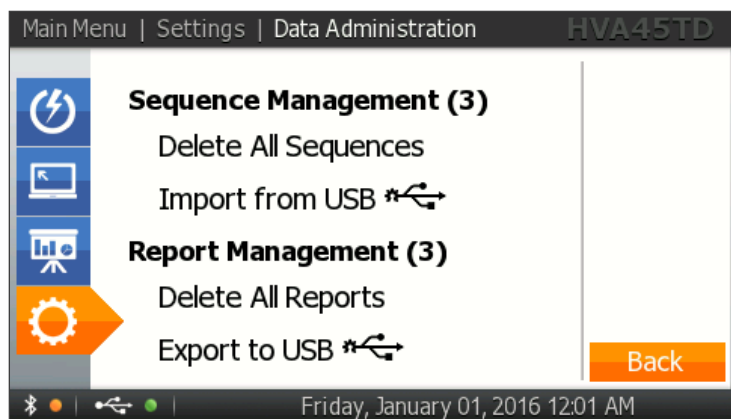

DA4: Report Management

In 4th line, number of available reports on the test set is given.

You have two options here:

- delete all reports in device
- export reports to USB

Reports can be exported in multiple file formats (HRE+HTML, HRE or HTML). The reports will remain on the device and may be deleted manually.

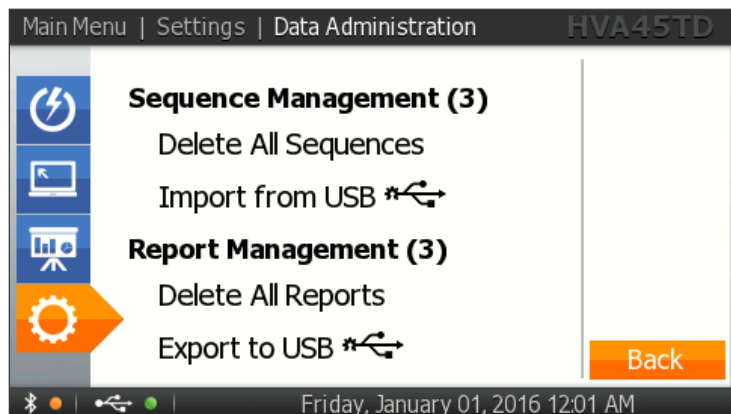

5 Application

Setup and Installation:

Connect the device in accordance with the technical specifications. Specification of the electrical connection values is mentioned on the rating plate.



NOTICE

If the device is connected to a voltage other than the rated voltage, the appliance may be destroyed:
Fire hazard.

We strongly advise you to use only spare parts specified by the manufacturer.

Avoid using defective mains, high voltage test leads or earthing cables for the installation and operation of the appliance, this can lead to life-threatening situations.

Connect the appliance as specified in the operating instructions. Use the cable types and cable colors as depicted on the connection schemes. The HV test lead can be operated in two different directions. Depending on the intended use (VLF, TD configuration or PD configuration), the connection direction must therefore be changed. Make sure that the direction matches your test purpose. See chapter 5.1 on the next page for more information.

Check the HV test lead, earthing lead, as well as all other cables for mechanical damage before each use! Should there be any defective cables on the measurement site, replace them immediately with new, undamaged ones.

Ensure that the ventilation ducts are clear all around during installation and operation. Keep a distance of at least 0.5 m from walls.

Switching on the device:

When switching on the device, observe the sequence in which the signal lamps (green, red) and the messages on the display light up. If one of the two lamps does not light up, the appliance must be switched off immediately via the "Emergency OFF" button  and the b2 Technical Support team contacted.

Further information on the signal lamps can be found in chapter 4.4.1 Front panel in the last section of the table.

While measuring:

If any unusual situation is suspected, the appliance must be

- switched off immediately using the "Emergency OFF" button  as well as test set main switch
- disconnected from the mains.

5.1 HVA68TD test lead

For HVA68TD test set, the latest member of the smartVLF® series, we have a new possibility for connecting the test set to the device under test. The HV test lead for the HVA68TD test set consists of an HV test lead and two different DUT adapters. For **transport** the DUT adapters are used as protective caps. Depending on your test purpose, one or the other DUT adapter needs to be unscrewed to screw that cable end into the HVA. The other adapter stays on the HV test lead and will be connected to DUT.

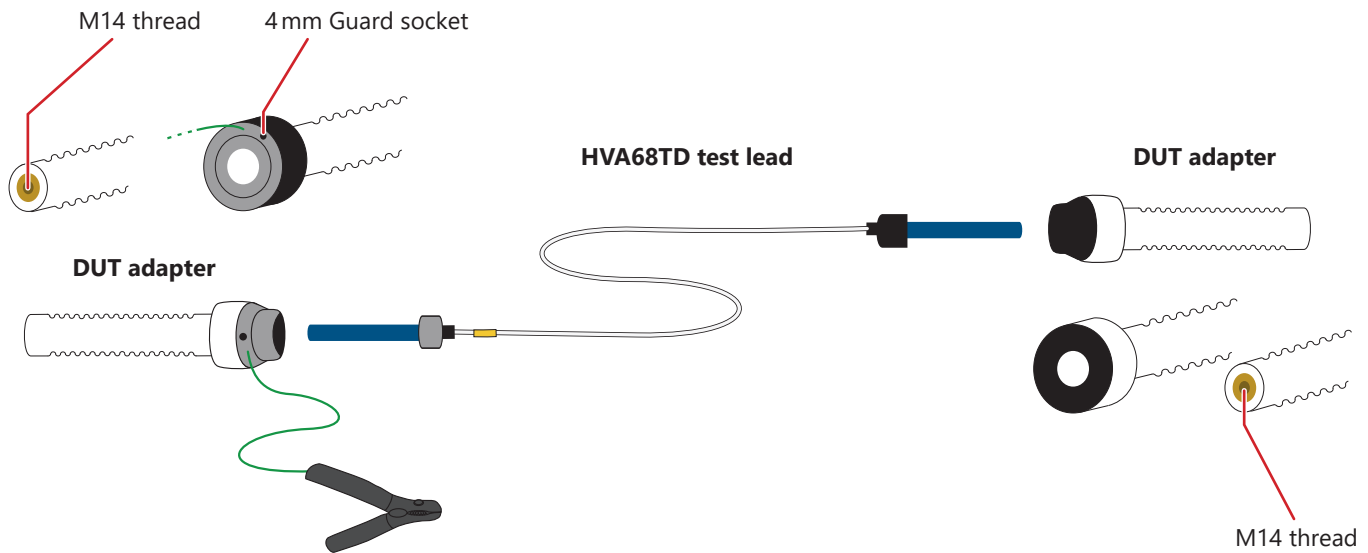

The different DUT adapters can be easily identified by the different materials and colors of the thread. The standard DUT adapter's thread is silver and made of metal and has a grounding clamp, the PD DUT adapter's thread is made of black plastics. Always consider that the HV test lead's knurled rotatable rings match the DUT adapter's material (metal – metal, plastics – plastics).

Standard configuration

For non-PD operation (VLF, TD, DC, MWT, Sheath test, Vacuum Bottle test) the HV plug with the black thread needs to be tightened into the HVA.

The plug with the metal thread needs to be connected to the DUT adapter with the metal thread and the grounding clamp.

Attention!

The grounding clamp of the DUT adapter is for overvoltage protection only. It does not provide earthing of the cable shield.

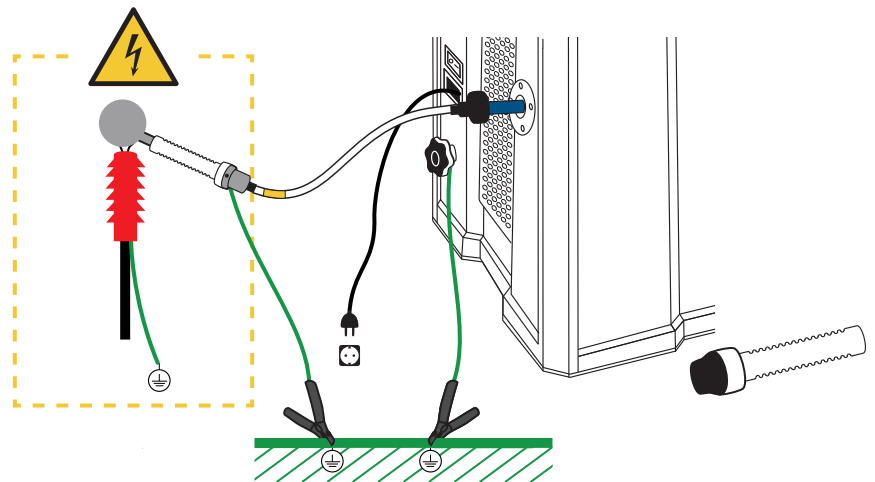

PD configuration

For PD operation the HV plug with the metal thread needs to be tightened into the HVA.

The plug with the black plastic thread needs to be connected to the DUT adapter with the black plastic thread.

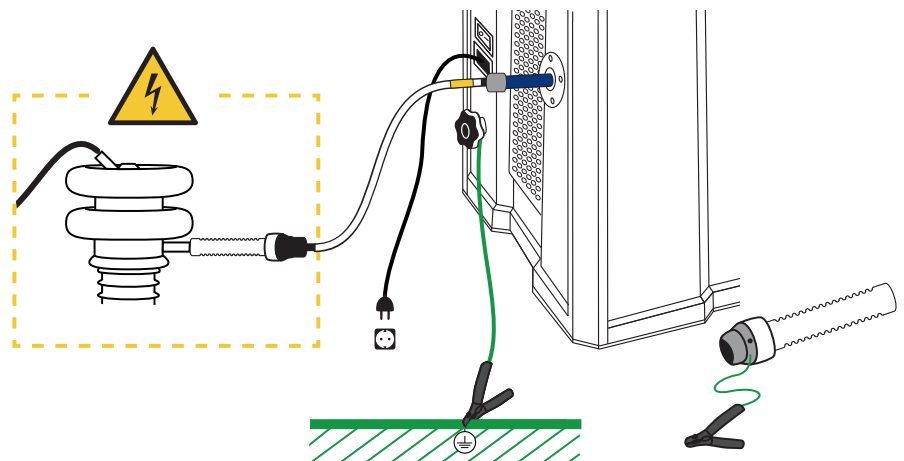

NOTICE

Use the standard configuration for all tests and applications described in this manual (on following pages).

The length of the standard HV test lead (7m) is already considered in the result of the APL measurement. If a longer HV test lead is used, the additional length needs to be subtracted from the displayed APL result.

5.2 VLF Withstand Test & DC Test



DANGER

Electric shock hazard

All procedures must comply with local safety regulations. Make sure you obey the five safety rules in the order listed in chapter 2.1 on page 8!

- Before operating the HVA test set, equipment set up procedure must be completed!
- Cables must be connected according to the sequence below!
- Before turning on the power supply and before activating the HVA test set, verify that all system elements are properly earthed!

Connection diagrams:

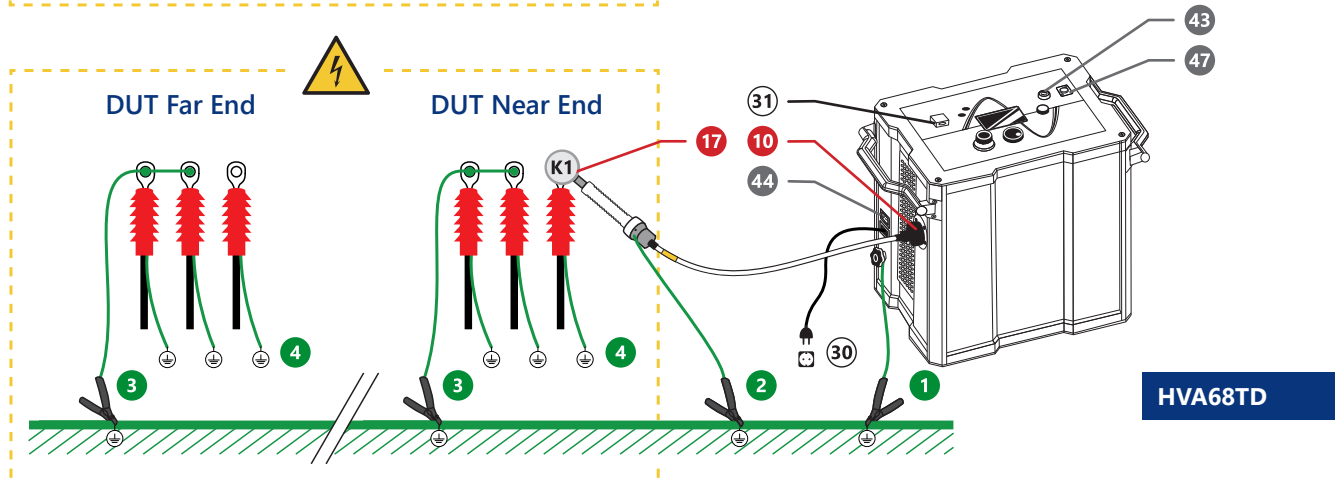
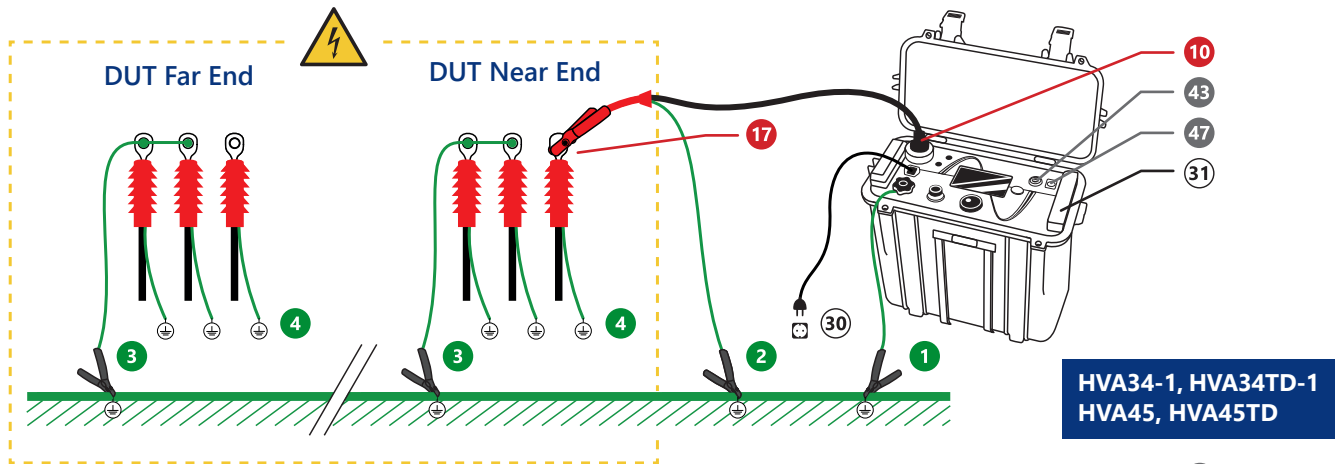
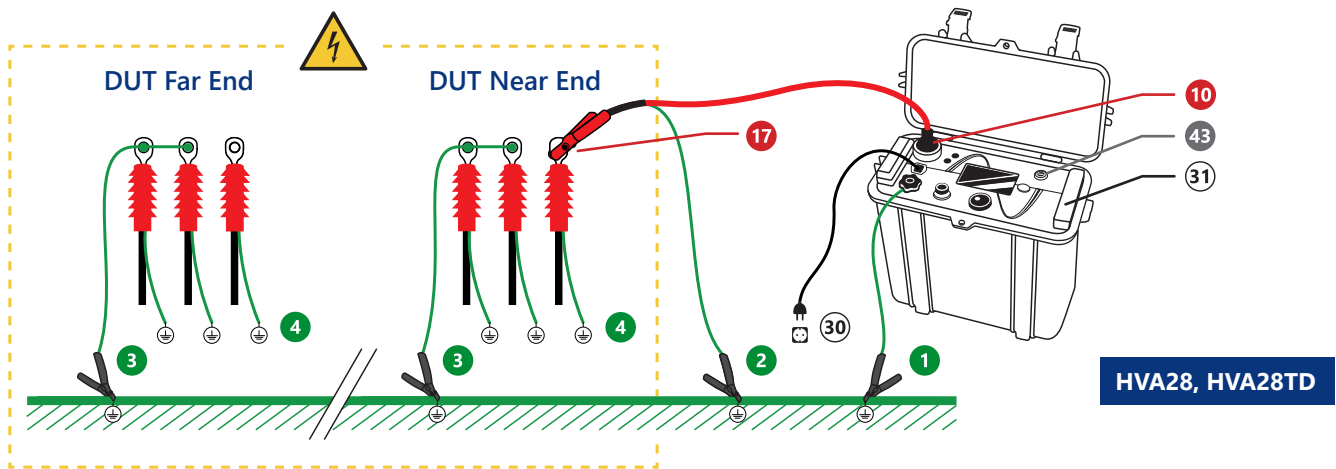

Procedure steps:

| | |
|-----------|---|
| S1 | <p>Connect all earthing cables.</p> <p>Discharge and earth the DUT complying with local safety regulations. Connect the earthing cable to the HVA earthing connector 1. Prepare earthing for measurement 3 4 on both Near and Far End.</p> |
| S2 | <p>Connect power supply 30 .</p> |
| S3 | <p>Connect all HV cable connections.</p> <ul style="list-style-type: none"> • Screw the HV test lead into the HVA HV output connector 10. • Connect the grounding clamp of the HV test lead 2 to protection earth. <p>Attention!</p> <p>The grounding clamp of the DUT adapter is for over-voltage protection only and does not provide safe earthing of the cable shield.</p> <ul style="list-style-type: none"> • Connect the other end of the HV test lead to the DUT 17 (HVA68TD: an example with corona shield K1 applied). |
| S4 | <p>Verify connections.</p> <p>Check that all cables are attached securely on both Near End and Far End.</p> |
| S5 | <p>Configure interlock plug.</p> <p>Verify that the HV emergency adapter is connected 47.</p> <p>If operating with remote controls (optional):</p> <p>Connect external lamps or remote switches.</p> |
| S6 | <p>Configure communication port.</p> <p>For USB data transfer mode, insert USB flash drive 31.</p> |
| S7 | <p>Turn "ON" the HVA main switch 44 (if applicable, e.g. HVA68TD).</p> |
| S8 | <p>Turn key switch 43 to "ON" position.</p> |
| S9 | <p>The HVA system automatically boots. Start-up default screen appears.</p> <p>Select appropriate option from default screen and proceed to appropriate section for further instructions.</p> |

Remark:

Apply the same order of the phases on both Near and Far End.

5.3 TD Diagnostics & Monitored Withstand Test

DANGER

Electric shock hazard

All procedures must comply with local safety regulations. Make sure you obey the five safety rules in the order listed in chapter 2.1 on page 8!

- Before operating the HVA test set, equipment set up procedure must be completed!
- Cables must be connected according to the sequence below!
- Before turning on the power supply and before activating the HVA test set, verify that all system elements are properly earthed!

Connection diagrams for standard connection:

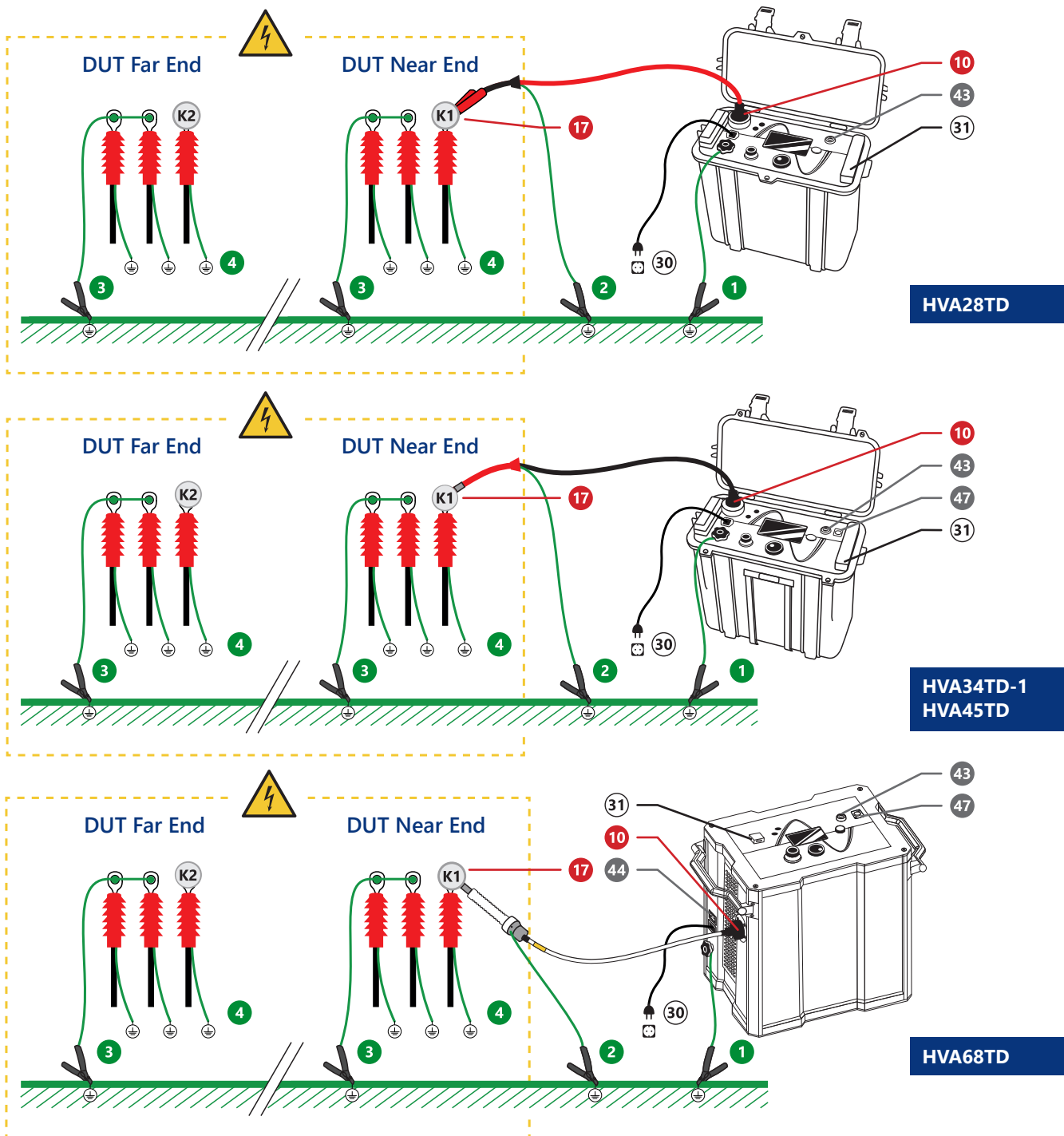

DUT Far End **DUT Near End**

43
47
31
10
44

HVA68TD



NOTICE

For voltages above 15 kV we recommend the use of corona shields for TD diagnostics.

Procedure steps:

| | |
|-----------|---|
| S1 | <p>Connect all earthing cables.</p> <p>Discharge and earth the DUT complying with local safety regulations. Connect the earthing cable to the HVA earthing connector 1. Prepare earthing for measurement 3 4 on both Near and Far End.</p> |
| S2 | <p>Connect power supply 30.</p> |
| S3 | <p>Connect all HV cable connections.</p> <ul style="list-style-type: none"> • Screw the HV test lead into the HVA HV output connector 10. • Connect the grounding clamp of the HV test lead 2 to protection earth. <p>Attention!</p> <p>The grounding clamp of the DUT adapter is for over-voltage protection only and does not provide safe earthing of the cable shield.</p> <ul style="list-style-type: none"> • Connect the other end of the HV test lead to the DUT 17. Optional: Mount corona shields (K1 and K2) to DUT. |
| S4 | <p>Verify connections.</p> <p>Check that all cables are attached securely on both Near End and Far End.</p> |
| S5 | <p>Configure interlock plug.</p> <p>Verify that the HV emergency adapter is connected 47.</p> <p>If operating with remote controls (optional):</p> <p>Connect external lamps or remote switches.</p> |
| S6 | <p>Configure communication port.</p> <p>For USB data transfer mode, insert USB flash drive 31.</p> |
| S7 | <p>Turn "ON" the HVA main switch 44 (if applicable, e.g. HVA68TD).</p> |
| S8 | <p>Turn key switch 43 to "ON" position.</p> |
| S9 | <p>The HVA system automatically boots. Start-up default screen appears.</p> <p>Select appropriate option from default screen and proceed to appropriate section for further instructions.</p> |

Remark:

Apply the same order of the phases on both Near and Far End.

5.4 TD Diagnostics & Monitored Withstand Test and Guard on Near End

DANGER

Electric shock hazard

All procedures must comply with local safety regulations. Make sure you obey the five safety rules in the order listed in chapter 2.1 on page 8!

- Before operating the HVA test set, equipment set up procedure must be completed!
- Cables must be connected according to the sequence below!
- Before turning on the power supply and before activating the HVA test set, verify that all system elements are properly earthed!

Connection diagrams:

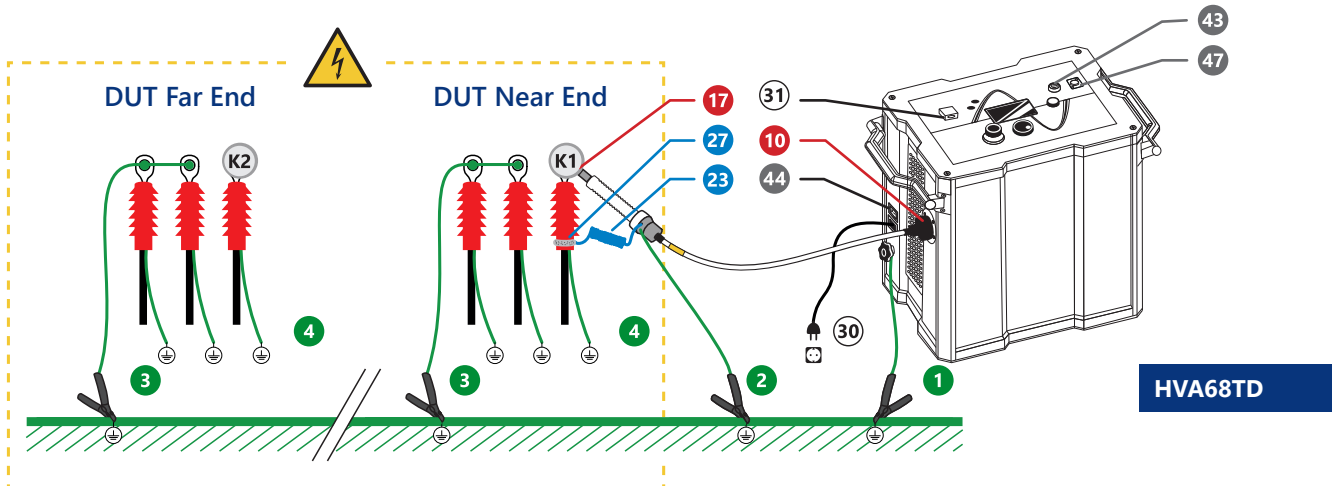
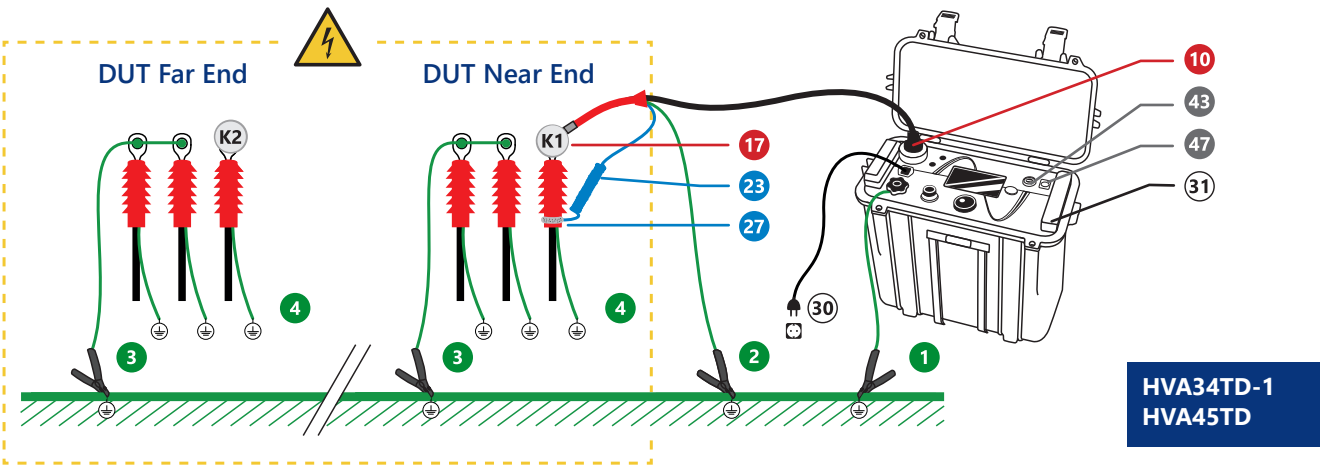
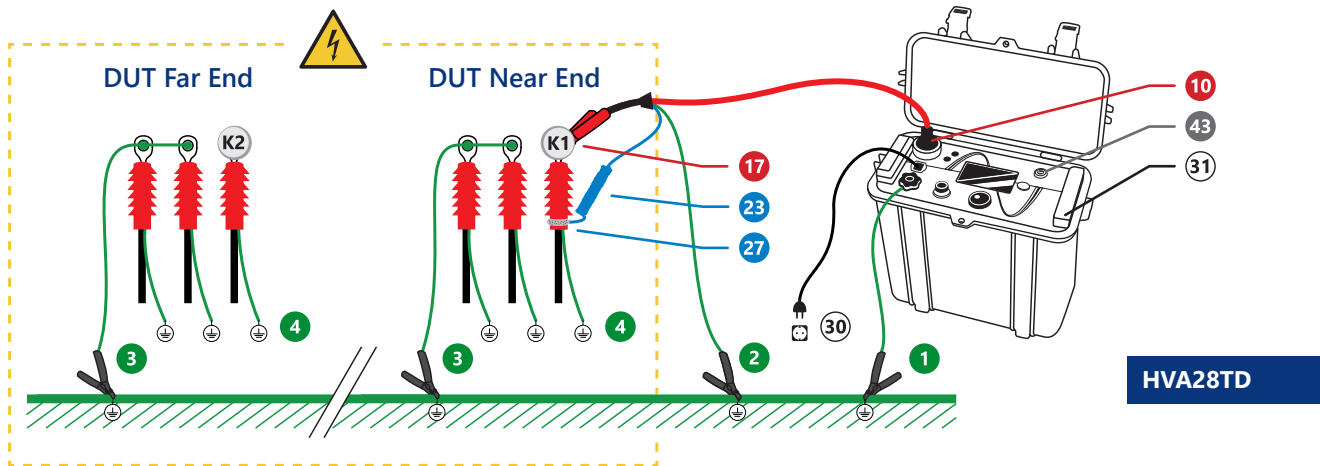

**NOTICE**

For voltages above 15 kV we recommend the use of corona shields for TD diagnostics.

Follow the introduction in chapter 5.3 TD Diagnostics & Monitored Withstand Test. After step S3, continue with steps OS1 to OS3, afterwards continue with steps S4 to S9.

Procedure steps:**Connections on Near End**

OS1 Fix the hook and loop fastener **27** at the termination. Place it as close as possible to the earth side of the DUT's termination, without touching the earth directly.

OS2 Connect the guard connection cable **23**:

- Connect the cable at the 4 mm socket at the HV test lead.
- Connect the other end of the cable at the conducting hook and loop fastener **27**.

Connections on Far End

OS3 Corona shield **K2** must be mounted on the DUT on the same phase at the Far End as on the Near End. As mentioned above, use of corona shields is highly recommended for voltages above 15 kV!

Remark:

Apply the same order of the phases on both Near and Far End.

5.5 TD Diagnostics & Monitored Withstand Test and Guard on Near and Far End

DANGER

Electric shock hazard
 All procedures must comply with local safety regulations. Make sure you obey the five safety rules in the order listed in chapter 2.1 on page 8!

- Before operating the HVA test set, equipment set up procedure must be completed!
- Cables must be connected according to the sequence below!
- Before turning on the power supply and before activating the HVA test set, verify that all system elements are properly earthed!

Connection diagrams:

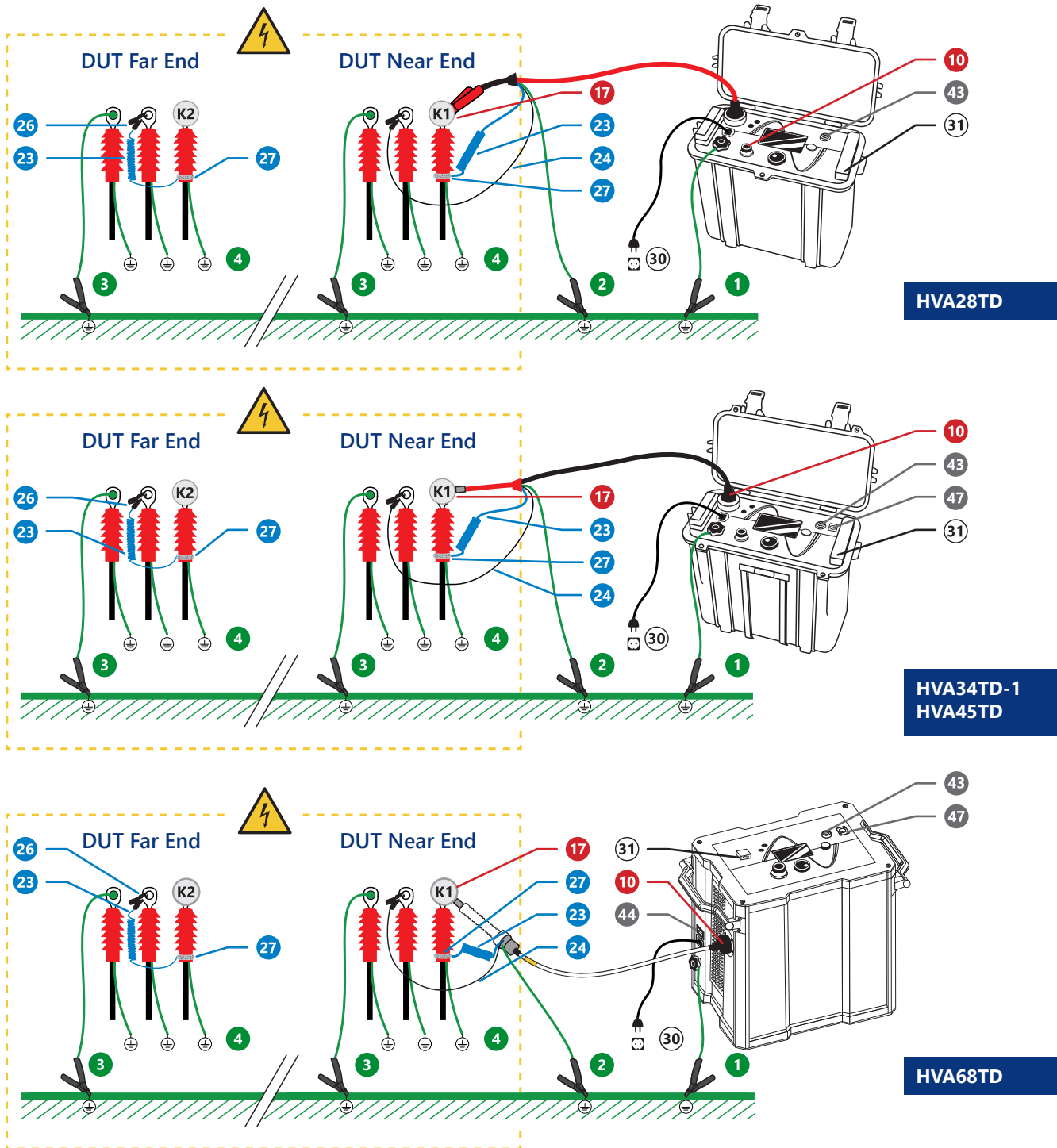



NOTICE

For very short cables with a cable length below 100 m we recommend use of the guard on the far end as well as on the near end. This is possible for three-phase systems or systems where you have a second connection from far end to near end.

Follow the introduction in chapter 5.3 TD Diagnostics & Monitored Withstand Test. After step S3, continue with steps OSG1 to OSG6, afterwards continue with steps S4 to S9.

Procedure steps:

Connections on Near End

- | | |
|-------------|---|
| OSG1 | Fix the hook and loop fastener 27 at the termination. Place it as close as possible to the earth side of the DUT's termination, without touching the earth directly. |
| OSG2 | Connect the guard connection cable 23 : <ul style="list-style-type: none"> • Connect the cable at the 4 mm socket at the HV test lead. • Connect the other end of the cable at the conducting hook and loop fastener 27. |
| OSG3 | Connect the guard connection cable from the leakage current from the end: <ul style="list-style-type: none"> • Connect the guard connection cable 24 with a dolphin clip to a phase that is not being tested or in operation. • Connect the other end of the guard connection cable at the 4mm socket at the HV test lead. |

Connections on Far End

- | | |
|-------------|--|
| OSG4 | Corona shield K2 must be mounted on the DUT on the same phase at the Far End as on the Near End. |
| OSG5 | Fix the conducting hook and loop fastener for leakage current detection: <ul style="list-style-type: none"> • Fix the hook and loop fastener at the termination to the phase which will be tested 27. Place it as close as possible to the earth side of the DUT's termination, without touching the earth directly. |
| OSG6 | Connect the guard connection cable 23 at the conducting hook and loop fastener 27 . Connect the other end of the cable with a dolphin clip 26 to the same phase, as used on the near end. |

Remark:

Apply the same order of the phases on both Near and Far End.

5.6 Sheath Test

DANGER



Electric shock hazard

All procedures must comply with local safety regulations. Make sure you obey the five safety rules in the order listed in chapter 2.1 on page 8!

- Before operating the HVA test set, equipment set up procedure must be completed!
- Cables must be connected according to the sequence below!
- Before turning on the power supply and before activating the HVA test set, verify that all system elements are properly earthed!

Connection diagrams:

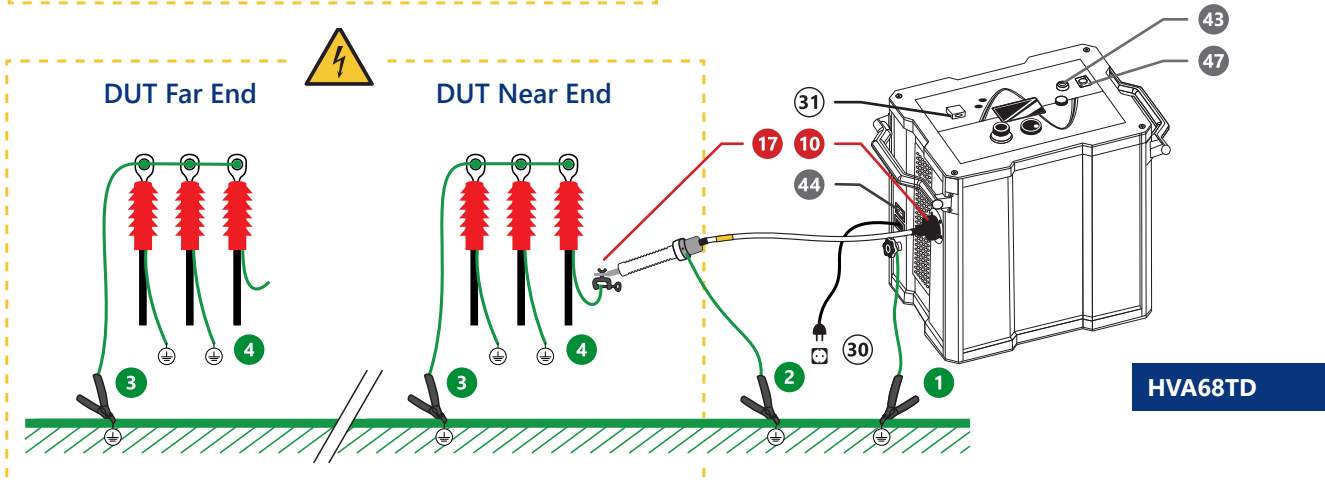
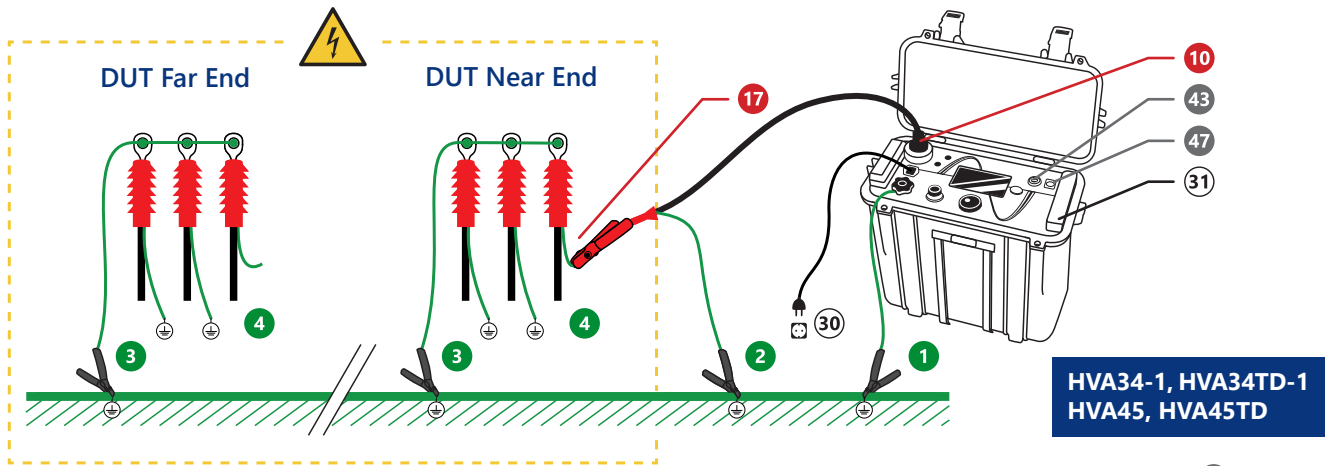
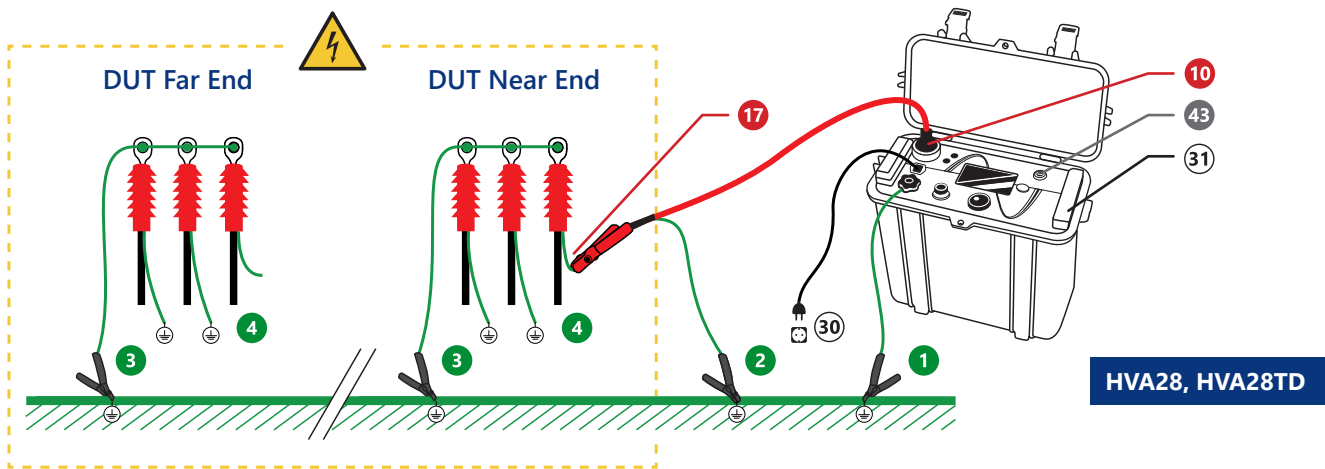

| | |
|-----------|---|
| S1 | <p>Connect all earthing cables.</p> <p>Discharge and earth the DUT complying with local safety regulations. Connect the earthing cable to the HVA earthing connector 1. Prepare earthing for measurement 3 4 on both Near and Far End.</p> <p>Attention! Since there is HV applied to the shield of the DUT, the shield of the tested phase needs to be removed from the earth potential on both ends of the cable! The shields of the other phases remain earthed.</p> |
| S2 | <p>Connect power supply 30.</p> |
| S3 | <p>Connect all HV cable connections.</p> <ul style="list-style-type: none"> • Screw the HV test lead into the HVA HV output connector 10. • Connect the grounding clamp of the HV test lead 2 to protection earth. <p>Attention! The grounding clamp of the DUT adapter is for over-voltage protection only and does not provide safe earthing of the cable shield.</p> <ul style="list-style-type: none"> • Connect the other end of the HV test lead to the DUT 17. |
| S4 | <p>Verify connections.</p> <p>Check that all cables are attached securely on both Near End and Far End.</p> |
| S5 | <p>Configure interlock plug.</p> <p>Verify that the HV emergency adapter is connected 47.</p> <p>If operating with remote controls (optional): Connect external lamps or remote switches</p> |
| S6 | <p>Configure communication port. For USB data transfer mode, insert USB flash drive 31.</p> |
| S7 | <p>Turn "ON" the HVA main switch 44 (if applicable, e.g. HVA68TD).</p> |
| S8 | <p>Turn key switch 43 to "ON" position.</p> |
| S9 | <p>The HVA system automatically boots. Start-up default screen appears. Select appropriate option from default screen and proceed to appropriate section for further instructions.</p> |

Remark:

Apply the same order of the phases on both Near and Far End.

5.7 Vacuum Bottle Test

DANGER



Electric shock hazard

All procedures must comply with local safety regulations. Make sure you obey the five safety rules in the order listed in chapter 2.1 on page 8!

- Before operating the HVA test set, equipment set up procedure must be completed!
- Cables must be connected according to the sequence below!
- Before turning on the power supply and before activating the HVA test set, verify that all system elements are properly earthed!

Connection diagrams:

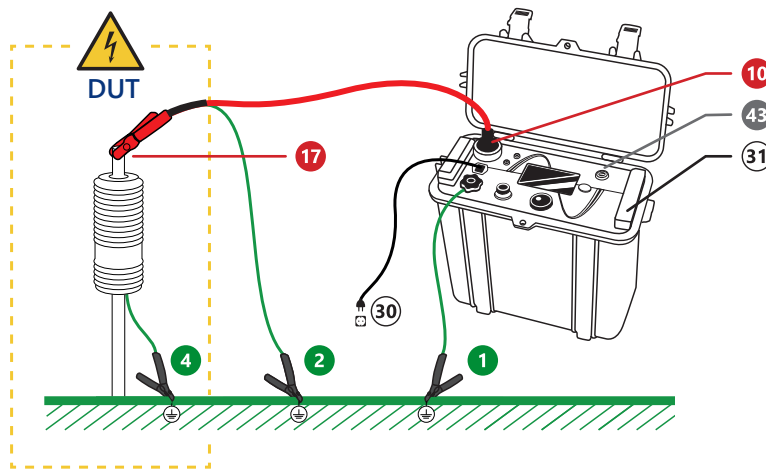

HVA28, HVA28TD

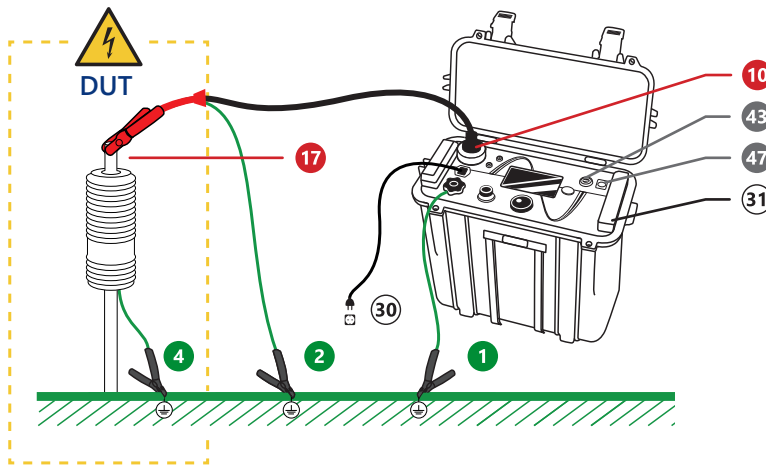

HVA34-1, HVA34TD-1
HVA45, HVA45TD

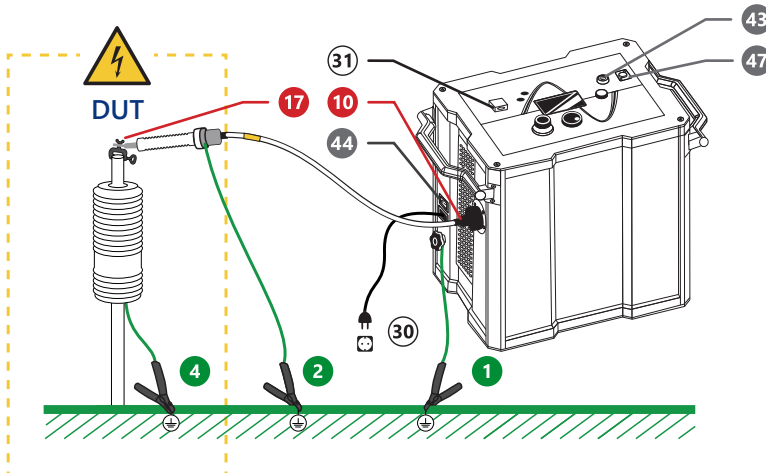

HVA68TD

Procedure steps:

| | |
|-----------|--|
| S1 | <p>Connect all earthing cables.</p> <p>Discharge and earth the DUT complying with local safety regulations. Connect the earthing cable to the HVA earthing connector 1. Prepare earthing for measurement 4.</p> |
| S2 | <p>Connect power supply 30.</p> |
| S3 | <p>Connect all HV cable connections.</p> <ul style="list-style-type: none"> • Screw the HV test lead into the HVA HV output connector 10. • Connect the grounding clamp of the HV test lead 2 to protection earth. <p>Attention!</p> <p>The grounding clamp of the DUT adapter is for over-voltage protection only and does not provide safe earthing of the cable shield.</p> <ul style="list-style-type: none"> • Connect the other end of the HV test lead to the DUT 17. |
| S4 | <p>Verify connections.</p> <p>Check that all cables are attached securely.</p> |
| S5 | <p>Configure interlock plug.</p> <p>Verify that the HV emergency adapter is connected 47.</p> <p>If operating with remote controls (optional):</p> <p>Connect external lamps or remote switches</p> |
| S6 | <p>Configure communication port.</p> <p>For USB data transfer mode, insert USB flash drive 31.</p> |
| S7 | <p>Turn "ON" the HVA main switch 44 (if applicable, e.g. HVA68TD).</p> |
| S8 | <p>Turn key switch 43 to "ON" position.</p> |
| S9 | <p>The HVA system automatically boots.</p> <p>Start-up default screen appears.</p> <p>Select appropriate option from default screen and proceed to appropriate section for further instructions.</p> |

6 Test procedure

6.1 Test modes overview

At the smartVLF® series you can choose between a manual mode and an auto test mode. At the manual mode you set your test parameters at the beginning (or during) the test and the parameters will be not saved. At the auto test mode you use pre-programmed test sequences. The HVA test set will drive the parameters from the test sequence. The test sequences can be created on the device or the PC. Details are discussed in chapter 6.4 Creating an auto test sequence.

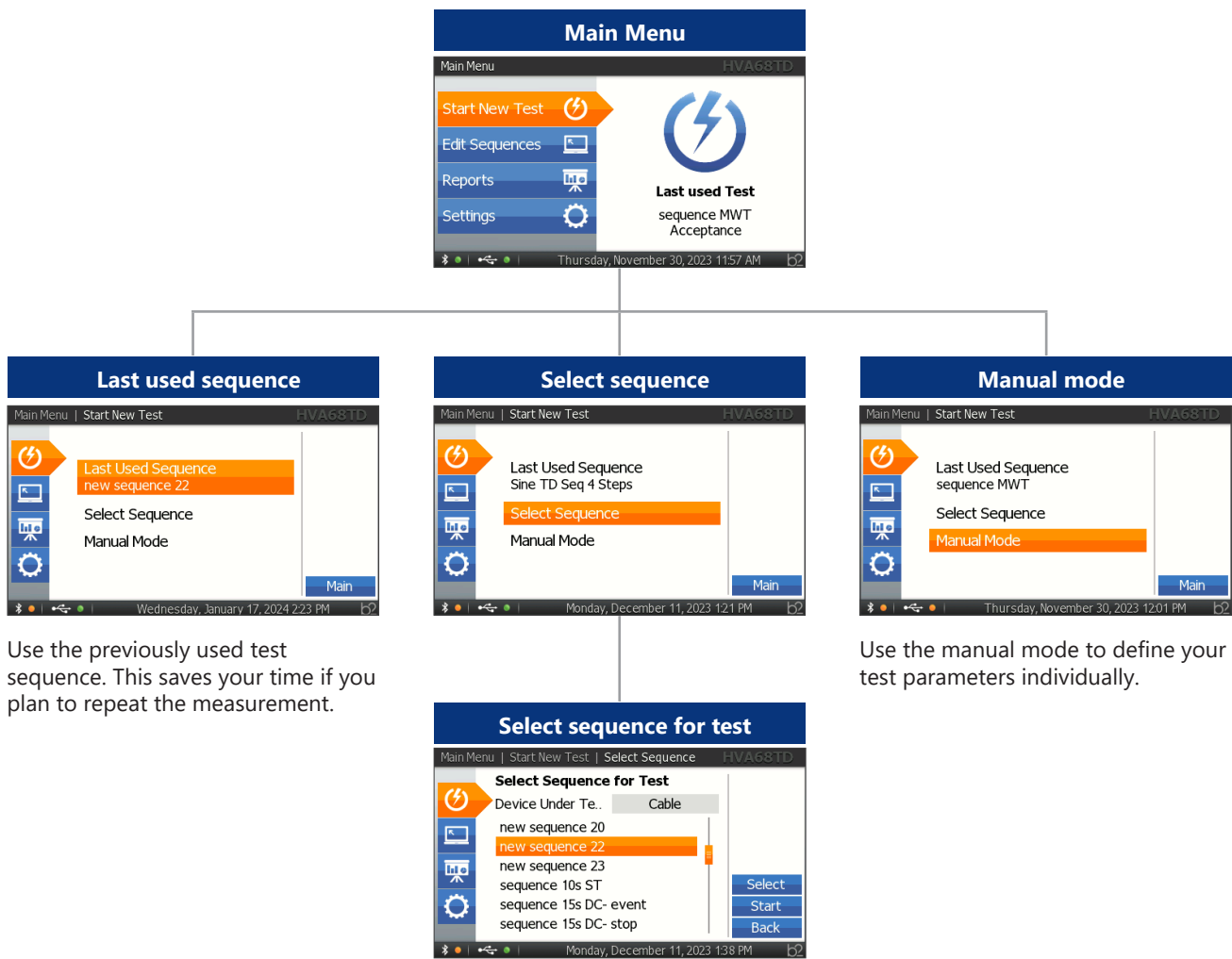

Use the previously used test sequence. This saves your time if you plan to repeat the measurement.

Use the manual mode to define your test parameters individually.

Select a pre-defined test sequence from the list.

6.2 Manual mode overview



6.2.1 Setting report parameters for a manual test mode

When starting a manual test, first step is to state the parameters for reporting. As depicted on the previous page, you can decide among **basic reporting**, **extended reporting** or **disabled reporting**. To set your reporting choice, go to **Settings / Instrument Setup / Reporting** or go to 4.2.1 Instrument setup, step IS5: Reporting for further information. For information on each reporting parameter, please go to Chapter 7.2: Reporting parameters.

Basic Report

If under **Settings / Instrument Setup / Reporting** you select "Basic" option, these are the parameters you are asked to fill in.

Remark:
Propag. velocity (v) appears for test sets with APL functionality only.

Confirm with the "Next" button.

Main Menu | Start a New Test | Report Details HVA68TD

| | |
|----------------------|------------|
| Report Title | TEST3 |
| Device Under Test | Cable |
| Voltage Rating | 2.0 kV |
| Insulation | XLPE |
| Propag. velocity (v) | 160.0 m/μs |
| Phase | A |

Back Next

Thursday, November 30, 2023 12:52 PM b2

Extended Report

If under **Settings / Instrument Setup / Reporting** you select "Extended" option, there are more parameters you are asked to fill in. However, you do not have to fill in every field.

Remark:
Propag. velocity (v) appears for test sets with APL functionality only. It will be used if an arc occurs. Specifying a line length also helps the APL to determine more precise results.

Confirm with the "Next" button.

Main Menu | Start a New Test | Report Details HVA68TD

| | |
|----------------------|----------------|
| Report Title | TEST3 |
| Device Under Test | Cable |
| Voltage Rating | 10.0 kV |
| Insulation | XLPE |
| Propag. velocity (v) | 160.0 m/μs |
| Phase | ABC |
| Company Name | B2 ELECTRONICS |

Thursday, November 30, 2023 1:29 PM b2

Main Menu | Start a New Test | Report Details HVA68TD

| | |
|-------------------|----------------|
| Company Name | B2 ELECTRONICS |
| Region Name | VORARLBERG |
| Station Name | STATION A |
| Line Length | 10000 Meter |
| Size of DUT | --- |
| Manufacturer Name | --- |
| Work Order | WO 123/23 |

Thursday, November 30, 2023 1:47 PM b2

Main Menu | Start a New Test | Report Details HVA68TD

| | |
|-------------------|-------------|
| Station Name | STATION A |
| Line Length | 10000 Meter |
| Size of DUT | --- |
| Manufacturer Name | --- |
| Work Order | WO 123/23 |
| Operator Name | ALEX |

Back Next

Thursday, November 30, 2023 1:28 PM b2

6.2.2 Characteristics of different output modes

When you complete the report details, you are ready to set up your measurement. Press the “Setup” button on the screen that appears on your test set next and select an output mode to carry out the HV testing:

Manual Test Mode Setup

Press the “Setup” button (on the right) to be able to set up the test parameters for your test.

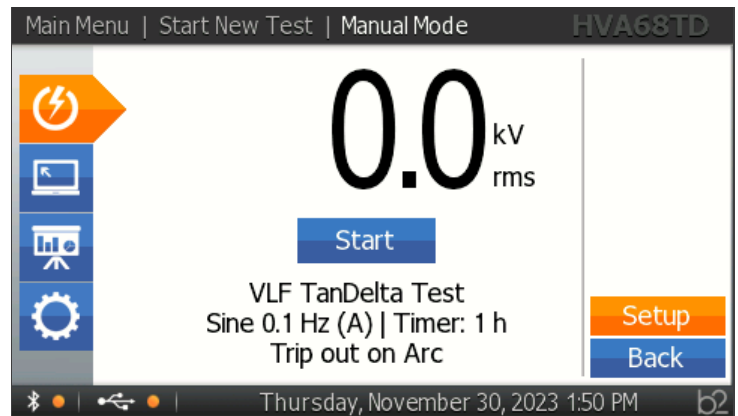

VLF Withstand Test

- Suitable for testing of extruded cables (e.g. XLPE) and other DUTs.
- Waveform: sine or square.
- Measured values are shown as RMS.

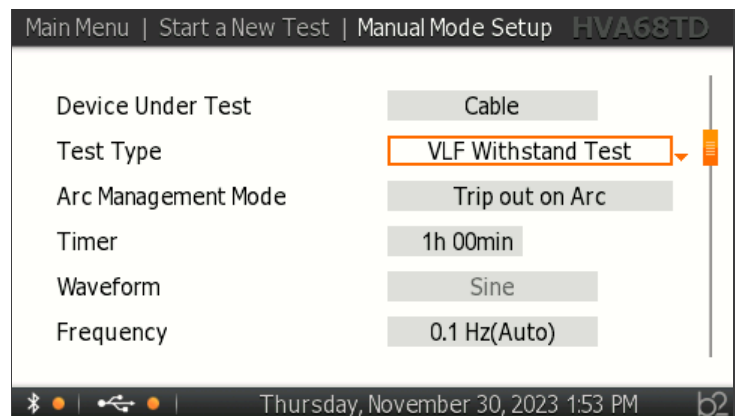

VLF Tan Delta Test

- Measures TD value of DUT according to selected standards and/or custom limits.
- “Burn on Arc” arc management mode: available only for test sets with APL functionality.
- Waveform: sine.
- Measured values are shown as RMS; TD in E-3.

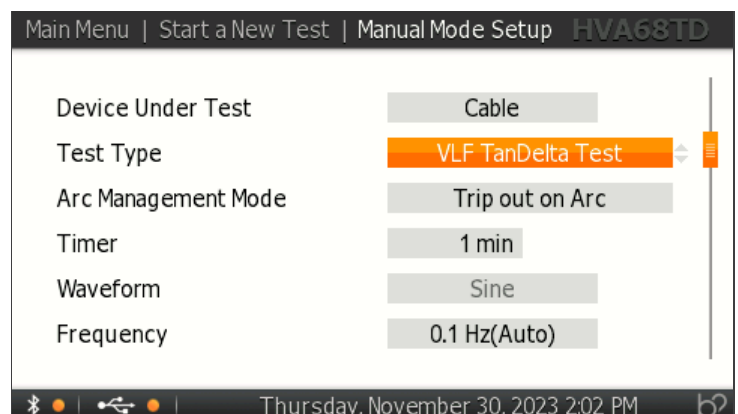

DC Test

- Single-polarity output. DUT is polarised (negative / positive) with respect to ground.
- NOT recommended for testing of extruded cables (e.g. XLPE).
- Measured value: dielectric loss of DUT (incl. leakage current across terminations).
- Most commonly used: DC-.

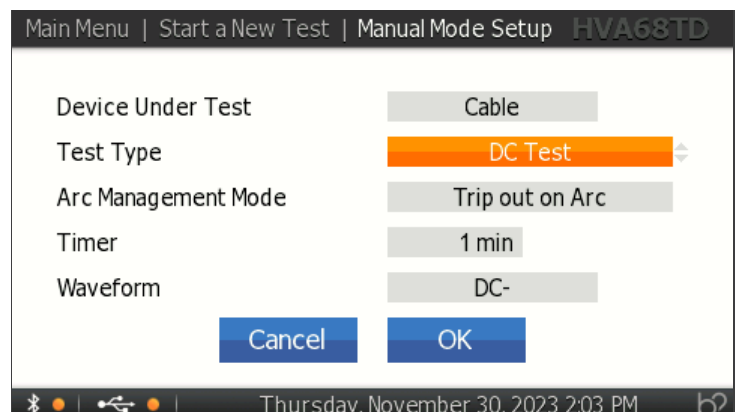

Sheath Test

- Duration is user defined.
- Max. test voltage: 10 kV
- Trip current range: 0.1-5.0 mA

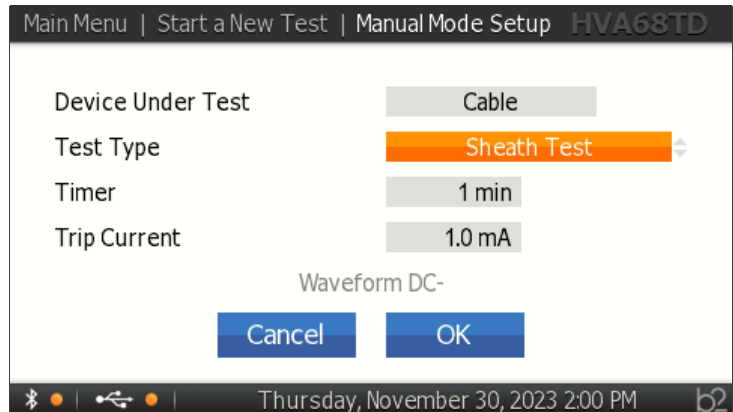

Sheath Fault Location

- Duration is user defined.
- Pulse is user defined.
- Available pulse ratios: 1:3 / 4s, 1:5 / 4s, 1:5 / 6s, 1:9 / 6s

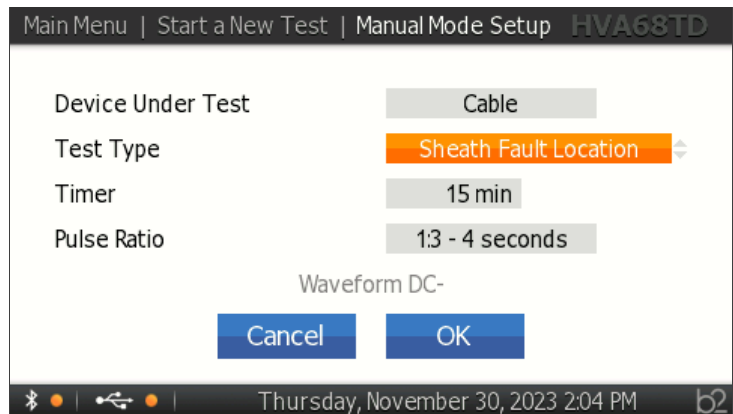

Vacuum Bottle Test

- Available in both manual and automatic test modes.
- Rise rate and trip current are user defined.
- Measured values are shown as peak voltage.
- NOT suitable for testing with DC above DUT voltage rating (X-ray hazard).

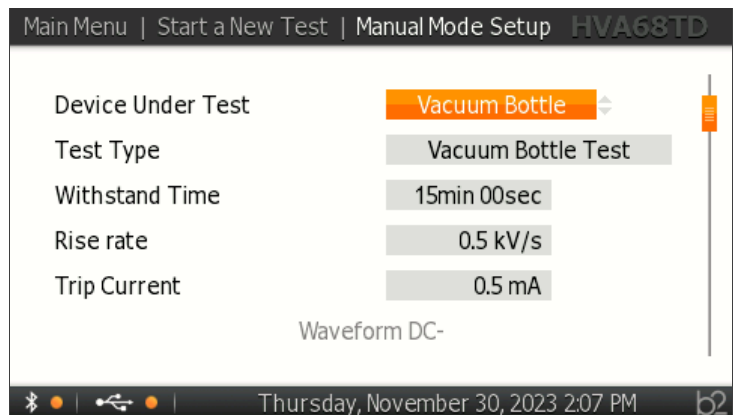

After setting up your test details, you are ready to start with the measurement. However, if you need more help on setting up the parameters for specific test types mentioned in this section, please follow the instructions in chapter 6.2.3 on the next pages.

Start the measurement

Press the "Start" button to proceed with the measurement.

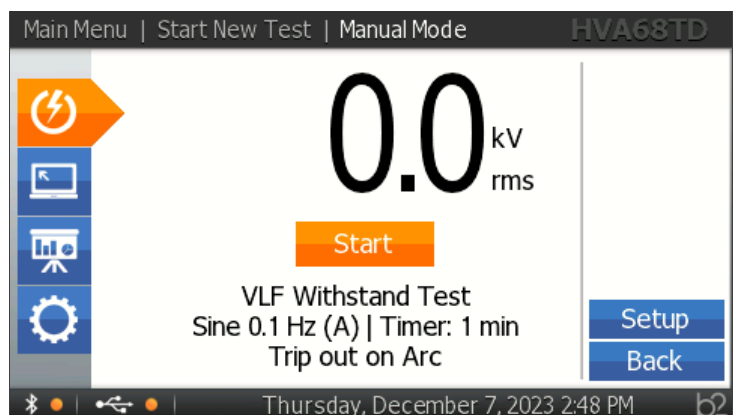

6.2.3 Manual test parameters

Select the DUT

Set the device to be tested.

The options are:

- Cable
- Motor
- Generator
- Transformer
- Switchgear
- Vacuum Bottle

Remark:

If reporting was activated, DUT type was defined there and cannot be adapted at this setup.

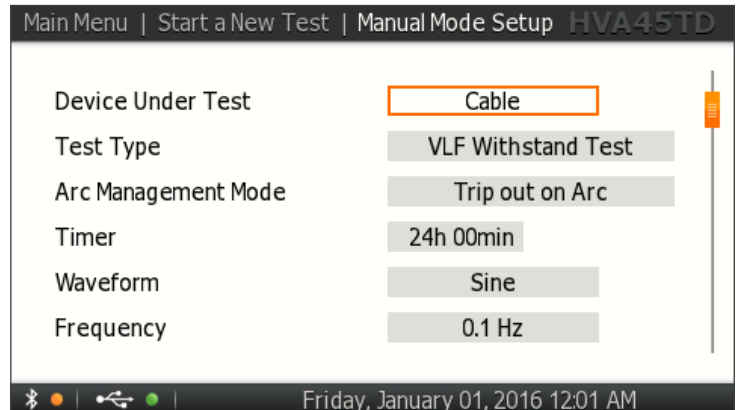

Set the arc management

Select one of the following:

- Trip out on arc
- Burn on arc

“Burn on Arc” arc management mode: make sure that the appropriate dwell time is selected (in the range 1 to 5 minutes).

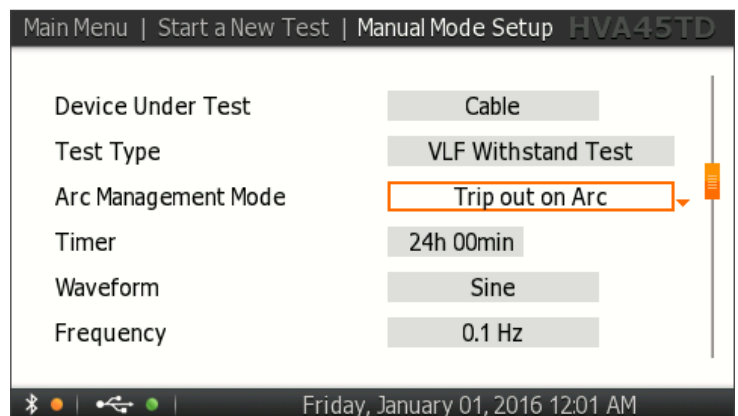

Set the test duration

Set the duration of the test.

There is a range to fit in.

- min. test duration: 1 minute
- max. test duration: 24 hours

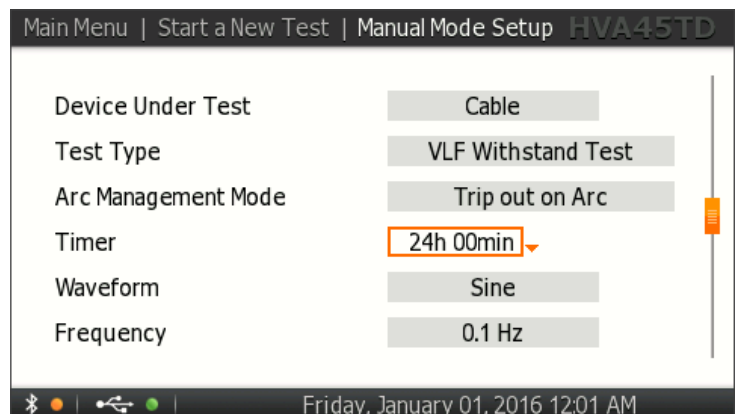

Set the waveform

Depending on the selected test type, the options are:

- Sine wave
- Square wave
- DC
- DC+
- DC-

Remark:

NOT applicable for VLF TD test, sheath test, sheath fault location and vacuum bottle test.

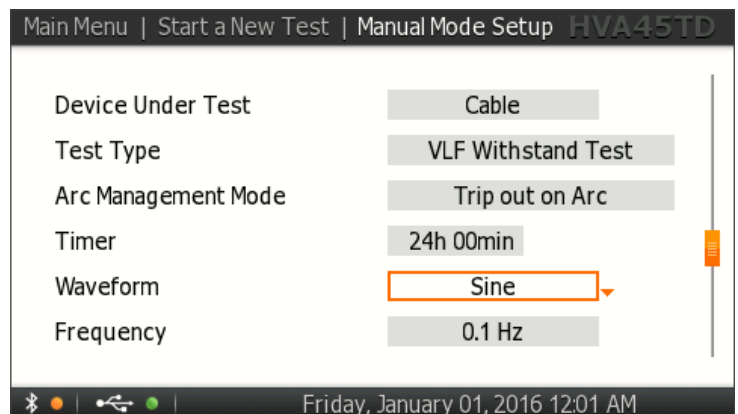

Set the frequency

Choose between these options:

- 0.1 Hz/Auto: recommended setting that automatically maintains the frequency as close to 0.1 Hz as possible.
- fixed frequency can be set from 0.01 Hz to 0.1 Hz in steps of 0.01 Hz.

Remark:
NOT applicable for DC test, sheath test, sheath fault location and vacuum bottle test.

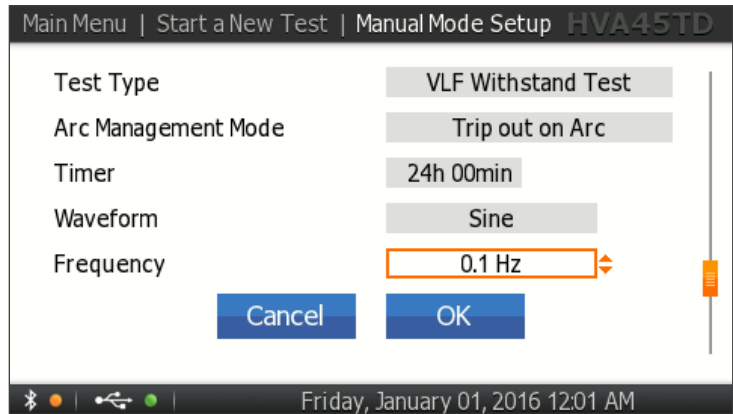

Set trip current

Set trip current and testing time:

- trip current: 0.1-5.0 mA
- test. time: 1 min-10 min

Remark:
Applicable for sheath test and vacuum bottle test.

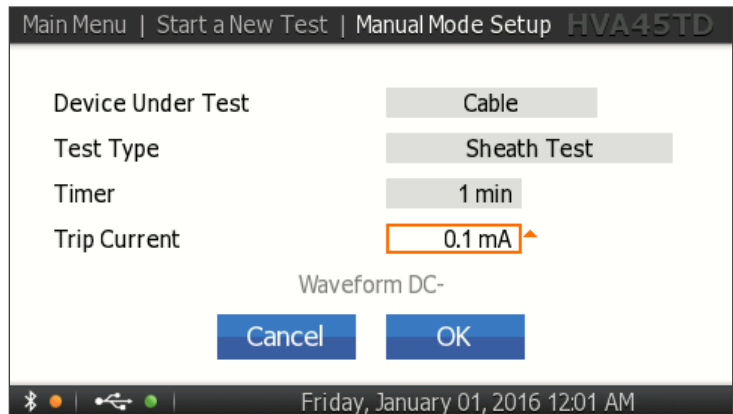

Set pulse/period

Set pulse/period and testing time:

- 1:3 / 4 s
- 1:5 / 4 s
- 1:5 / 6 s
- 1:9 / 6 s

Remark:
Applicable only for sheath fault location.

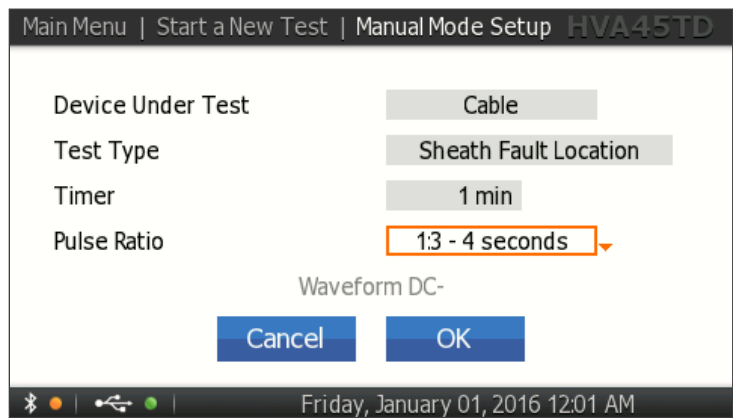

Confirm your settings

To start a test, please confirm your settings with the "OK" button.

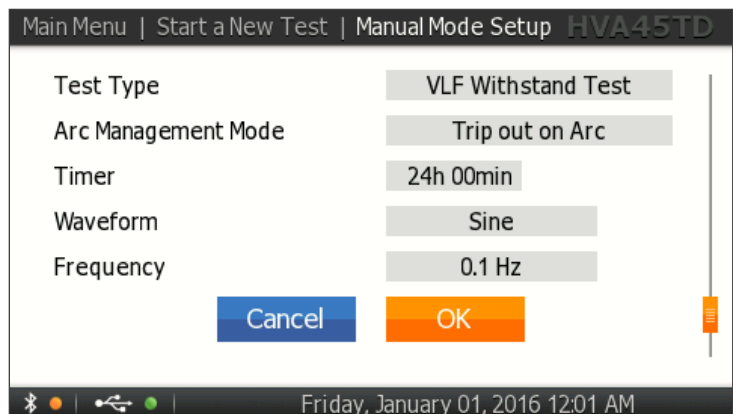

Pre-set test voltage

Entering the test voltage before activating the manual mode test by pressing "Start" is optional. In manual mode, the voltage can be set once the test has been initiated.

To set the test voltage, rotate the navigation knob until you reach the voltage value. The dot in upper right hand corner indicates that the test voltage is in pre-set mode. To accept the value, push in the knob. The dot in upper right hand disappears, indicating that the test voltage is set.

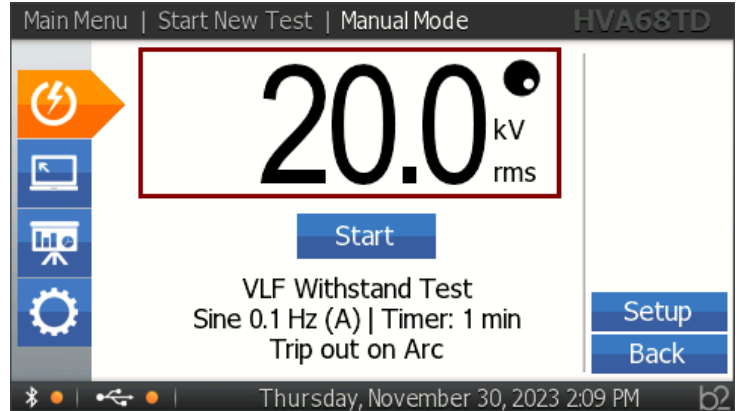

6.2.4 Running a manual test

Start the test

In order to start the test, press the "Start" button (it turns orange).

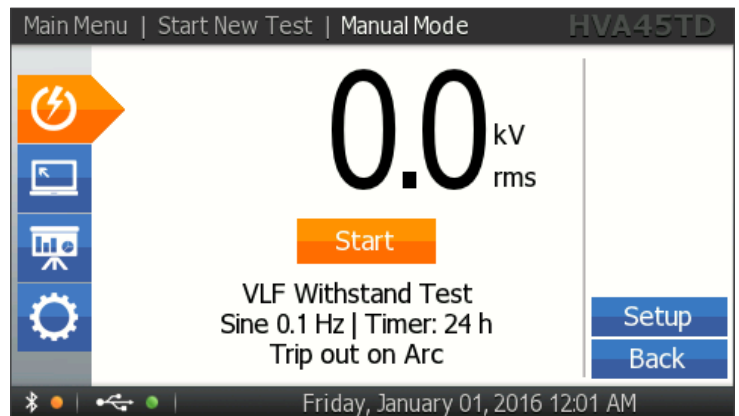

HV activation

Once the activation screen appears, press the HV switch 40 within 10 seconds.

Remark:
If the HV switch is not activated within 10 seconds, the "Manual Mode" screen will reappear.



Test start-up

This is an indication that the HVA test set is initializing the test.

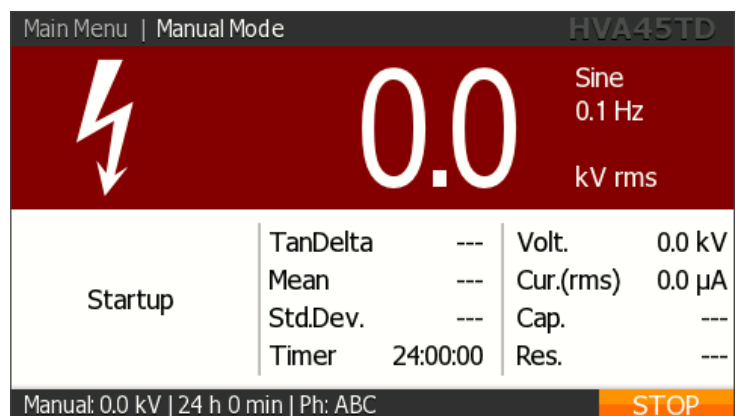

Set the test voltage

If there is not already a test voltage pre-set or you want to modify the voltage value, rotate the navigation knob to set the voltage value.

The value will be updated, if the knob is not rotated for 2 sec.

The selection and the navigation knob will disappear at the voltage value and the new set voltage will be displayed in the left bottom corner.

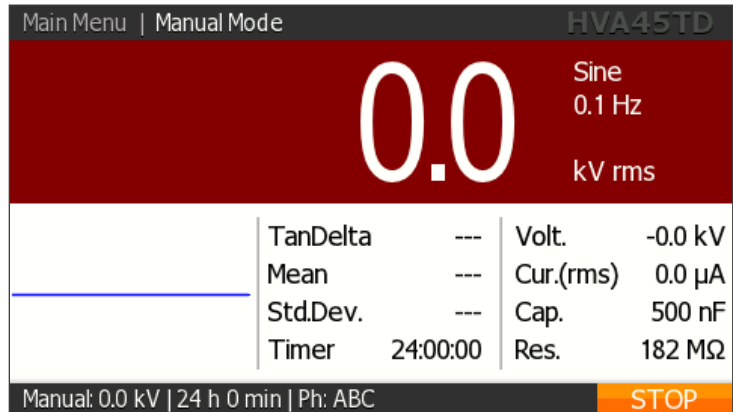

Test is running

Test begins automatically.

The timer value in the fourth line indicates the remaining testing time.

The bottom line of the screen (the black stripe) displays the pre-set values.

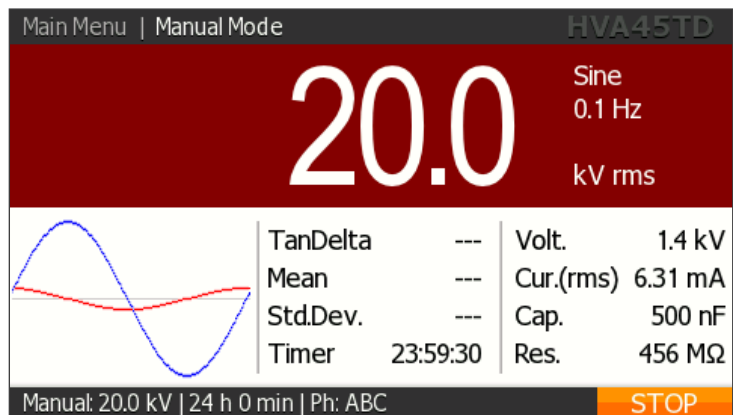

6.2.5 Test summary - test successful

This example depicts the VLF withstand test. Test summary for all other tests is depicted in the same manner.

Test Successful summary

Display indicates successful end of manual test. Further options are displayed on the right side. You may:

- test the next phase
- start a new test
- view the corresponding report
- go back to the main menu

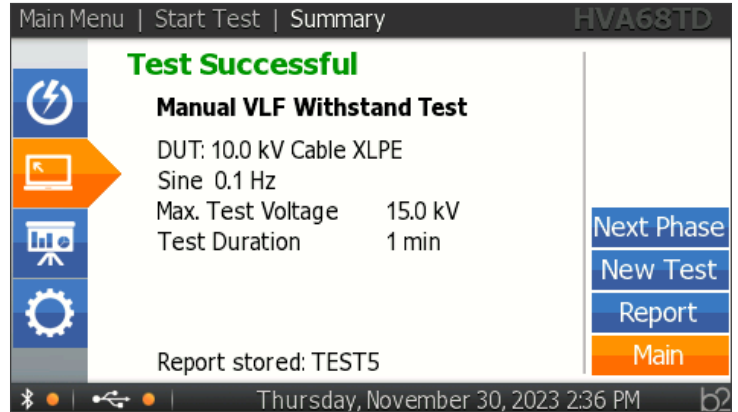

6.2.6 Test summary - test failed

These examples depict the VLF withstand test. Test summary for all other tests is depicted in the same manner.

The line on arc location/APL appears only for test sets with APL functionality included.

Test failed summary 01

Display indicates that the test failed with a short test summary.

Information on arc location:
Test failed, arc was located.
Result written in green: SCF > 4
(See Glossary on p. 4.)

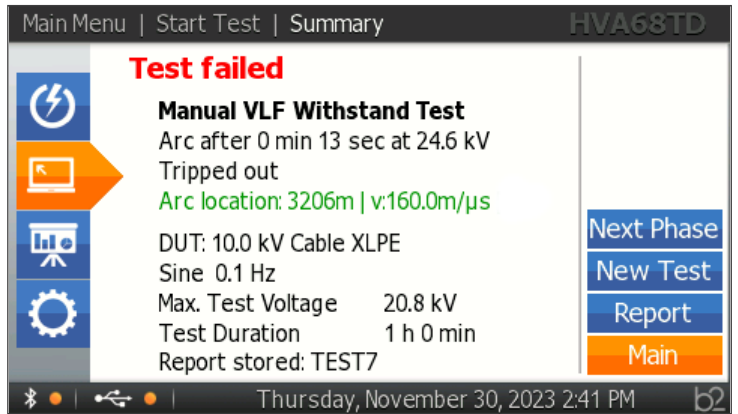

Test failed summary 02

Display indicates that the test failed with a short test summary.

Information on arc location:
Test failed, arc was located.
Result written in orange: 2 < SCF < 4
(See Glossary on p. 4.)

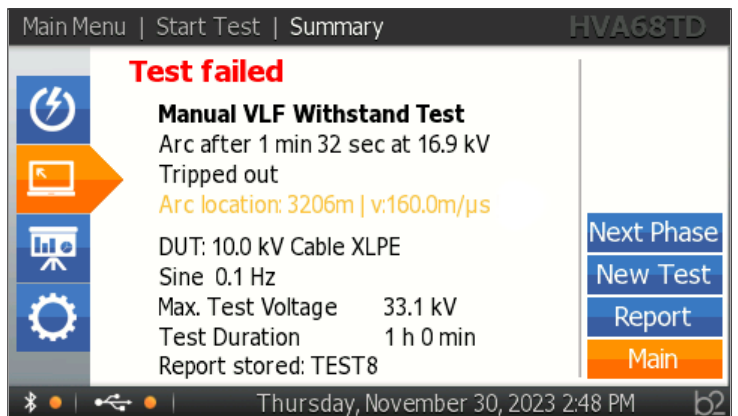

Test failed summary 03

Display indicates that the test failed with a short test summary.

Information on arc location:
Test failed, arc was not able to be located. SCF < 2
(See Glossary on p. 4.)

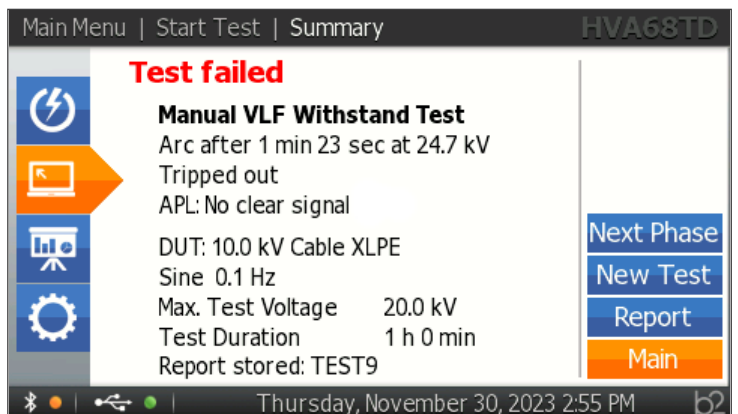

6.3 Running an auto test - overview

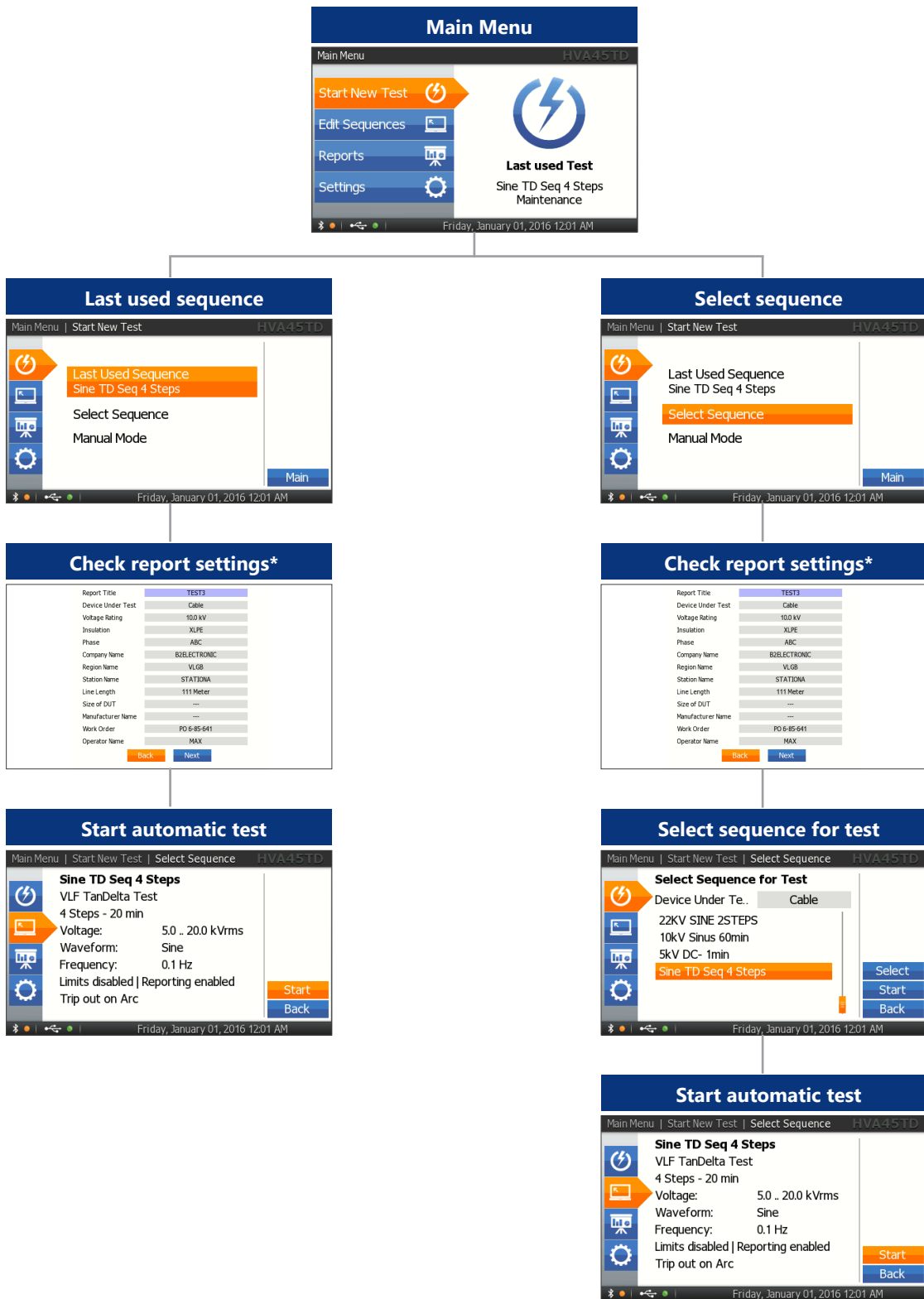

*Check report settings:
This screen appears only in case reporting has been enabled.

6.3.1 Running an auto test - last used sequence

In order to run a test with a "Last Used Sequence" it is necessary that such a sequence has been added to the test set prior to this measurement. You either created it in a manual mode (see Chapter 6.2 for further information) or you imported it via USB flash drive (see Chapter 4.1.4 or 4.2.4 for further information).

Start New Test menu

Confirm that you plan to start a new test.

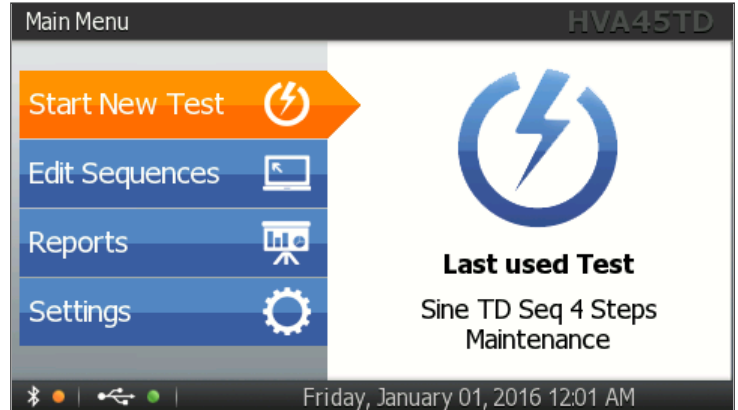

Select sequence menu

Choose this option to proceed with the same test sequence as was last used.

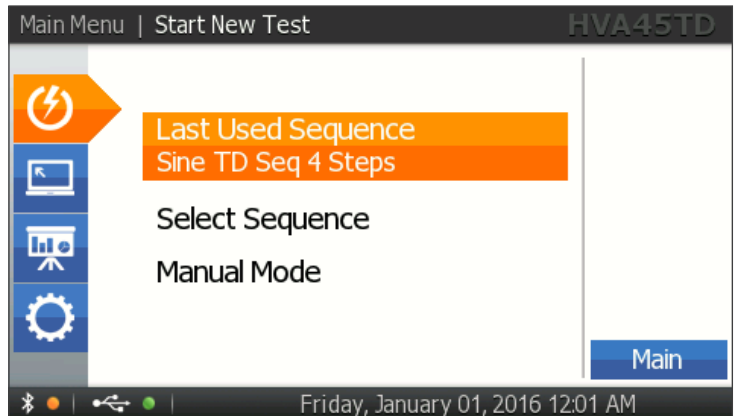

Check report settings

Report settings for the selected sequence appear here. You may modify the lines, if you would like to make some changes.

Remark:
These are the report parameters for the extended report.
Basic report settings: "Settings" / "Instrument Setup" / "Reporting"

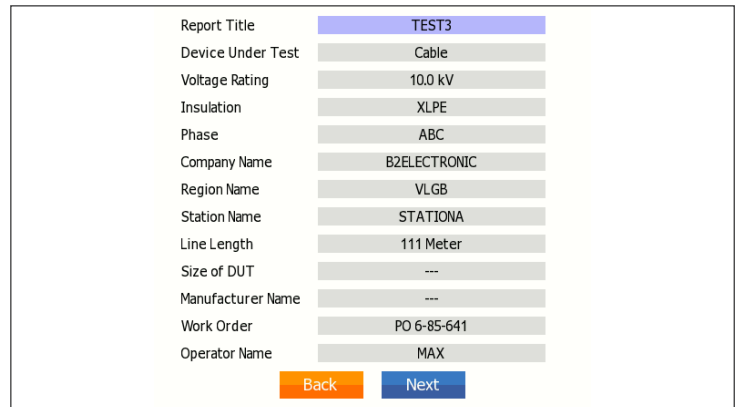

Sequence summary

The summary of the sequence parameters appears.

Press the "Start" button to proceed with the measurement.

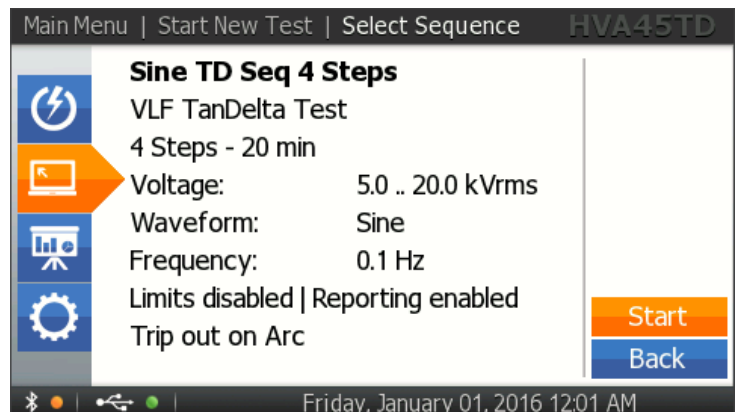

HV activation

Once the activation screen appears, press the HV switch within 10 seconds.

Remark:
If the HV switch is not activated within 10 seconds, the "Manual Mode" screen will reappear.

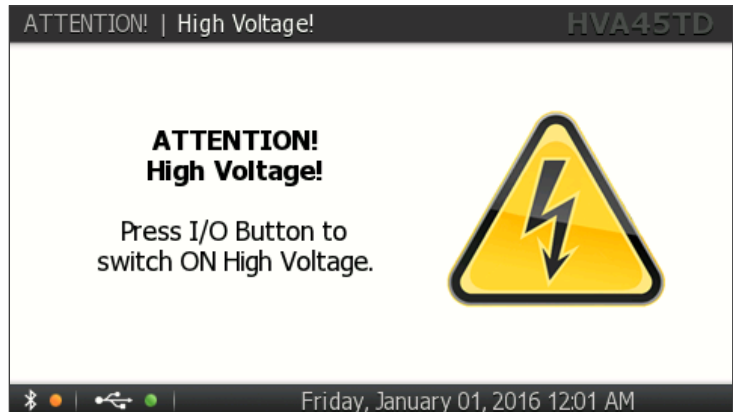

Test start-up

This is an indication that the HVA test set is initializing the test.

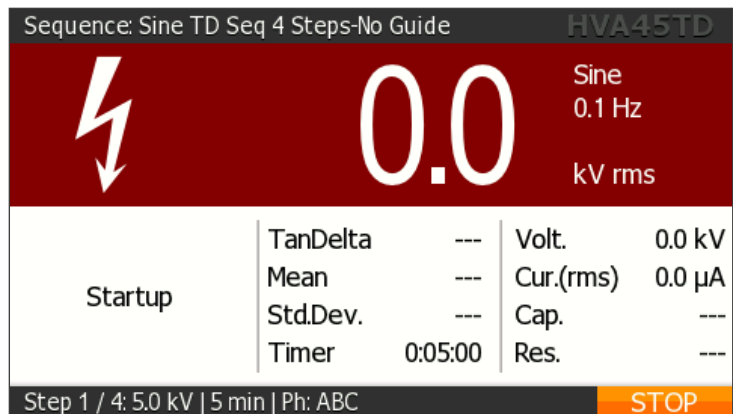

Test is running

Test begins automatically. According to the test sequence the pre-set test voltage values and steps will be applied.

The timer value in the fourth line indicates the remaining testing time.

The information in the footer are the pre-set values.

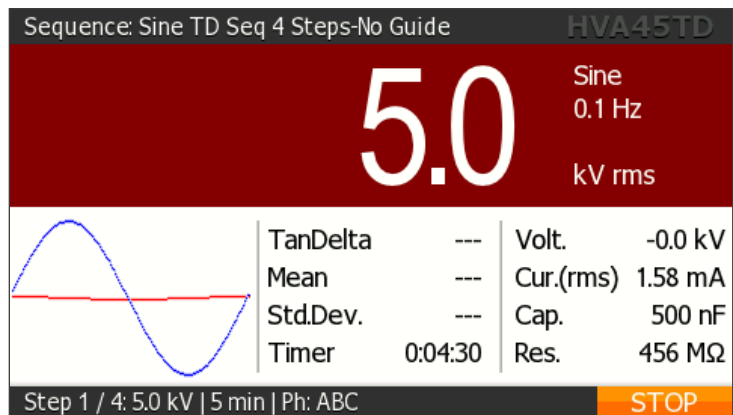

Test summary

Display indicates end of auto test. Further options are displayed on the right side. You may:

- test the next phase
- start a new test
- view the corresponding report (if reporting is enabled and test type is not sheath fault location)
- go back to the main menu

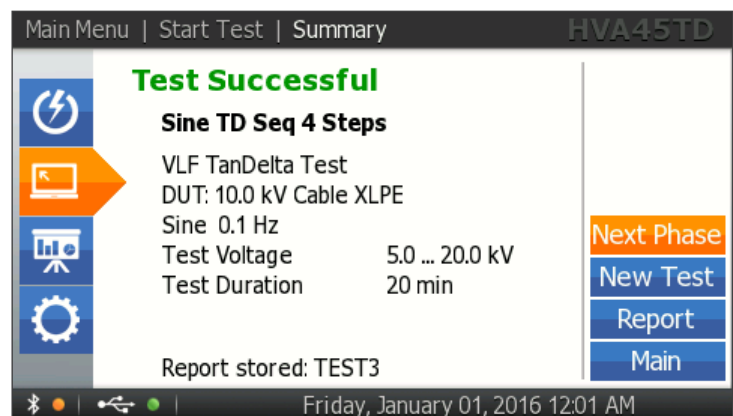

6.3.2 Running an auto test - select a sequence from the list

In order to "Select Sequence" to run a test it is necessary that such a sequence has been added to the test set prior to this measurement. You either created it in a manual mode (see Chapter 6.2 for further information) or you imported it via USB flash drive (see Chapter 4.1.4 or 4.2.4 for further information).

Select sequence menu

In the "Start New Test" menu, choose this option to go to the selection of all available test sequences.

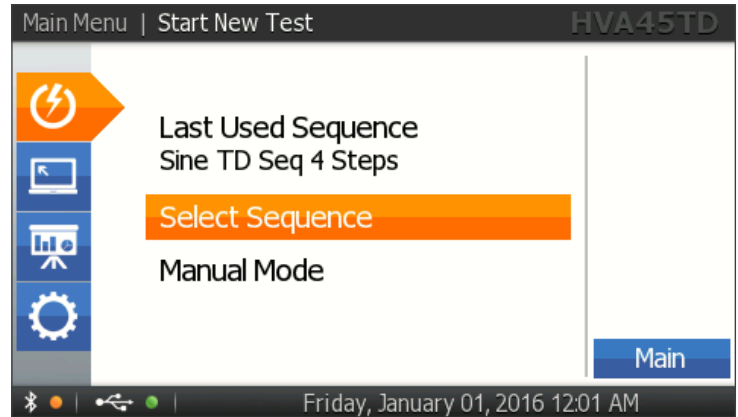

Set the report details

First, check the parameters for the reporting.

Note:

These are the report parameters for the extended report.

Basic report example: p. 40

Basic report settings: "Settings" / "Instrument Setup" / "Reporting"

Confirm with the "Next" button at the bottom of the screen.

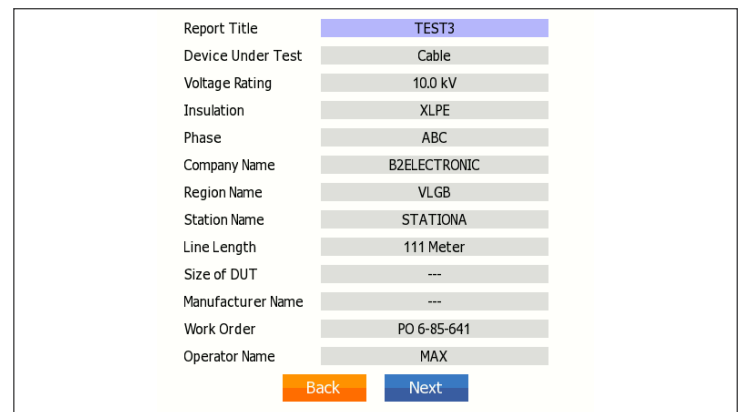

Select the sequence

Dependent on the Device Under Test you can select the sequence from the list and press "Start" button.

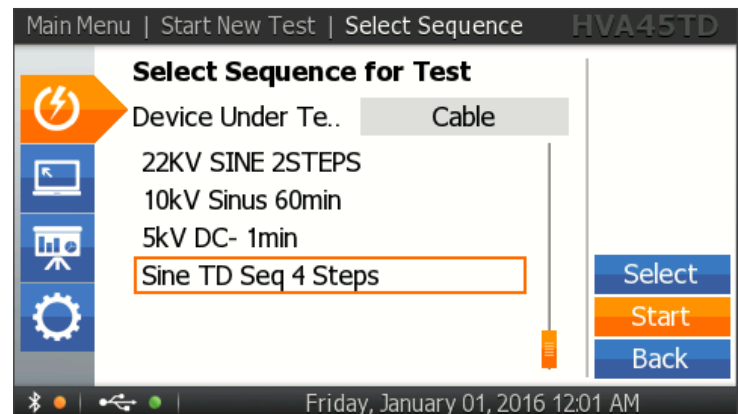

Sequence summary

The summary of the sequence parameters appears.

Press the "Start" button to proceed with the measurement.

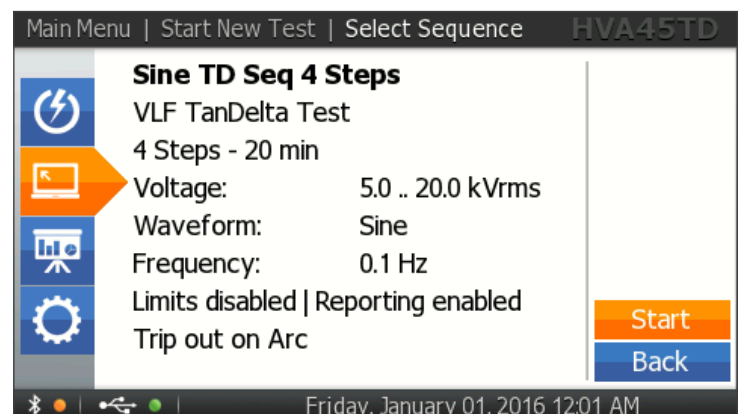

HV activation

Once the activation screen appears, press the HV switch within 10 seconds.

Remark:
If the HV switch is not activated within 10 seconds, the previous screen will reappear.

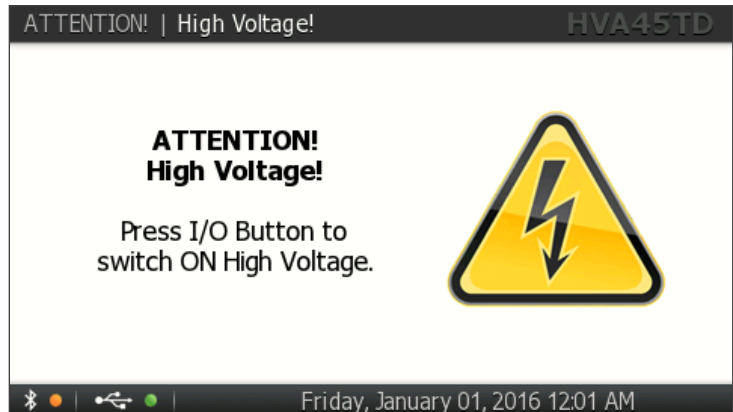

Test start-up

This is an indication that the HVA test set is initializing the test.

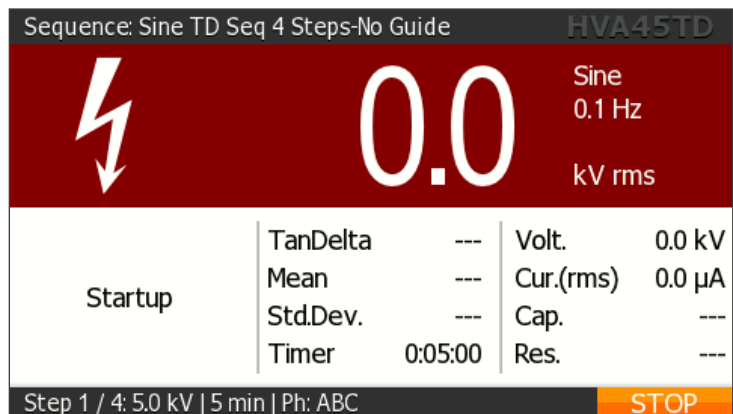

Test is running

Test begins automatically. According to the test sequence the pre-set test voltage values and steps will be applied.

The timer value in the fourth line indicates the remaining testing time.

The information in the footer are the pre-set values.

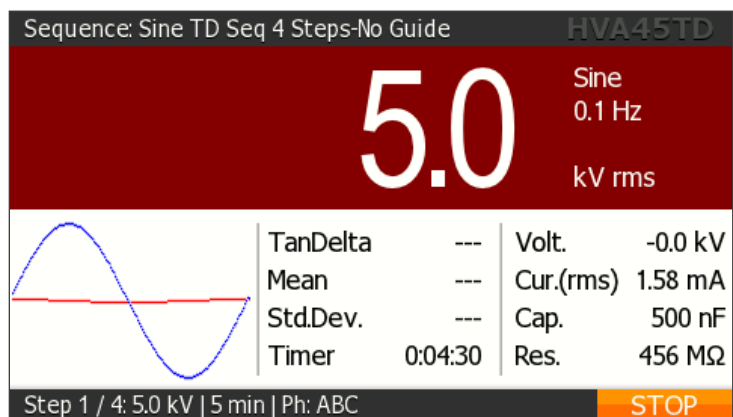

Test summary

Display indicates end of automatic test.

Further options are displayed on the right side. You may:

- test the next phase
- start a new test
- view the corresponding report
- go back to the main menu

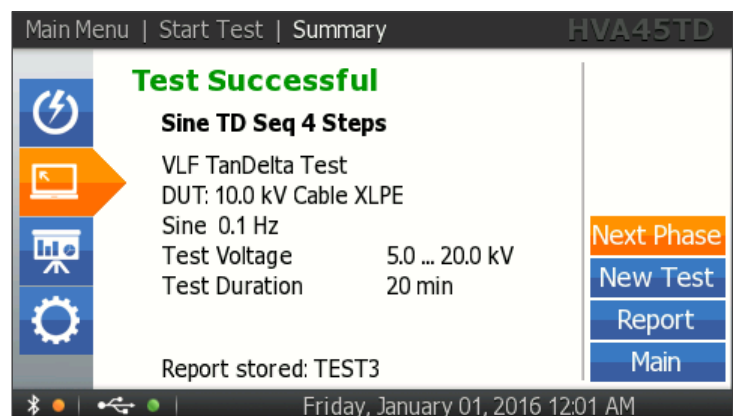

6.4 Creating an auto test sequence - overview

This HVA test mode facilitates satisfying specific requirements (e.g. IEEE, IEC standards) when testing and allows to program customizable test sequences that can be recalled at any time. The test sequence can be configured, modified and saved at any time before testing.



see chapter 6.4.1 Configuring a new auto test sequence

see chapter 6.4.2 Modifying an existing auto test sequence

6.4.1 Configuring a new auto test sequence

Edit Sequences menu

To configure a new sequence, we start at the "Edit Sequences" menu.

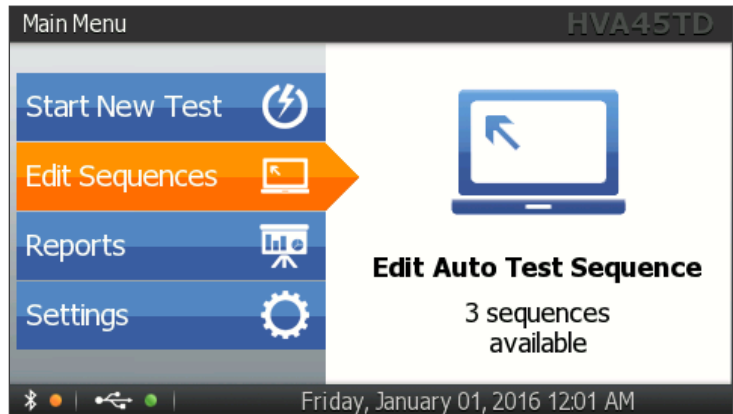

Create a new sequence

Pick a sequence from the list and on the right side, click on the "New" button.

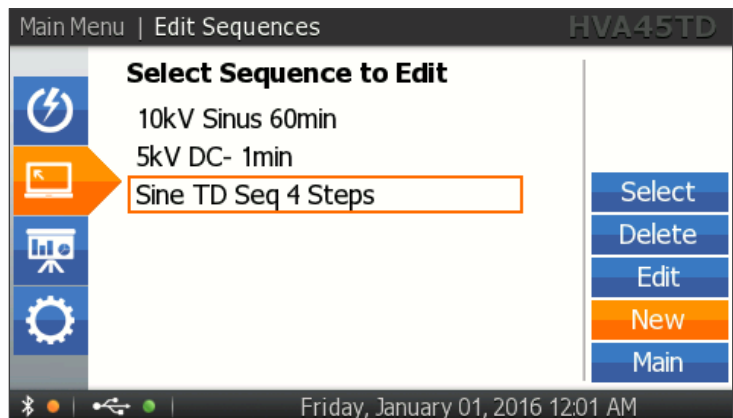

Sequence info: Title

The title you type in will appear in the list of available sequences later on.

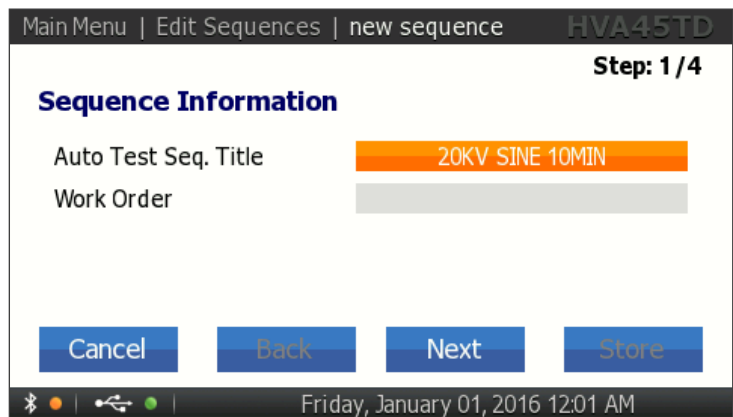

Sequence info: Work order

Type in the work order.

Remark:
This field is only optional but can be useful for the reporting.

To continue, press "Next" button.

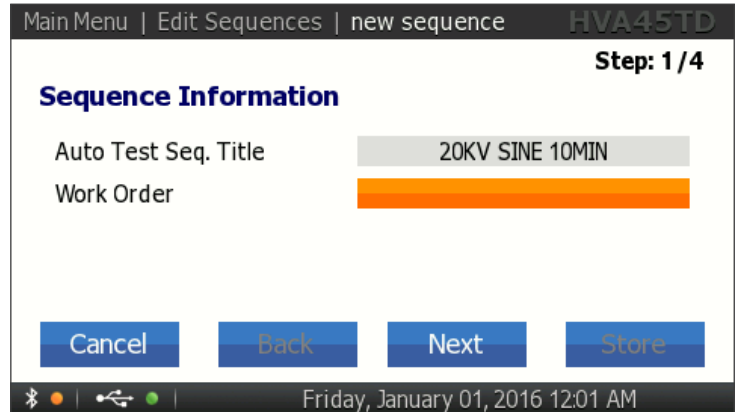

DUT

Set the device to be tested.
The options are:

- Cable
- Motor
- Generator
- Transformer
- Switchgear
- Vacuum Bottle
- Other

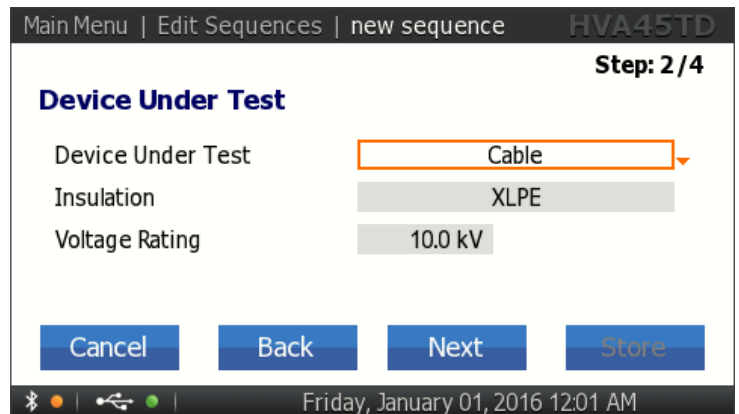

DUT: Insulation

Set the cable insulation type:

- XLPE
- TRXLPE
- PILC
- EPR
- EPR (black) / (pink) / (dis. res.)
- PE
- PVC
- HYBR
- Other

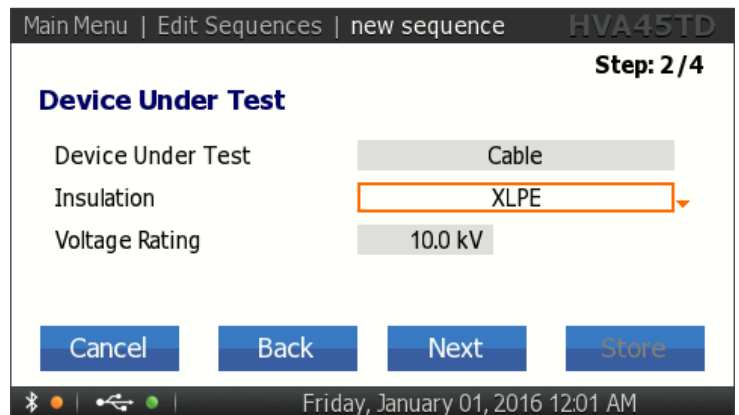

DUT: Voltage rating

The possible range is 0 to 50 kV.

Remark:
This is a characteristic of the DUT.
Based on this value we can then calculate U_0 .

To continue, press "Next" button.

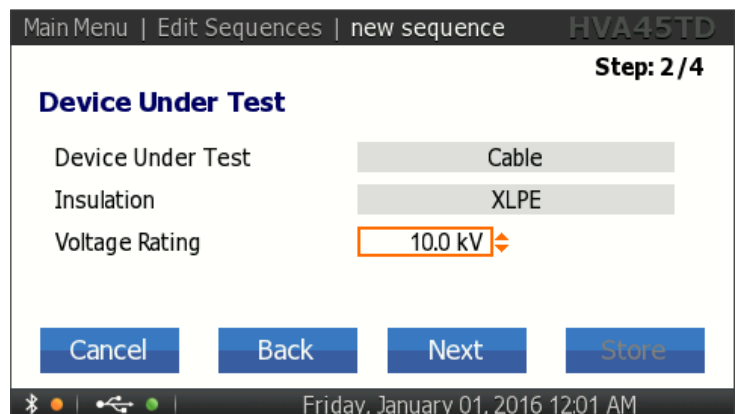

Test specification: Test type

Select an appropriate test.

- VLF Withstand test
- VLF Tan Delta test
- MWT
- DC test
- Sheath test

Remark:

Test type is dependent on DUT type or on test guide.

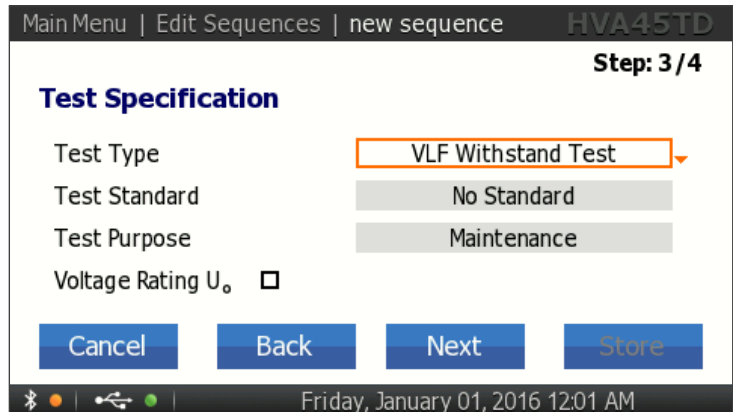

Test specification: Test standard

Set the test standard, e.g.:

- HD620
- IEEE400.2-2013 Int
- IEEE400.2-2013
- Q GDW 11838-2018
- No standard

Remark:

If you select a test standard / guide, some of the parameters are locked. E.g. IEEE 400.2 -> no DC test possible

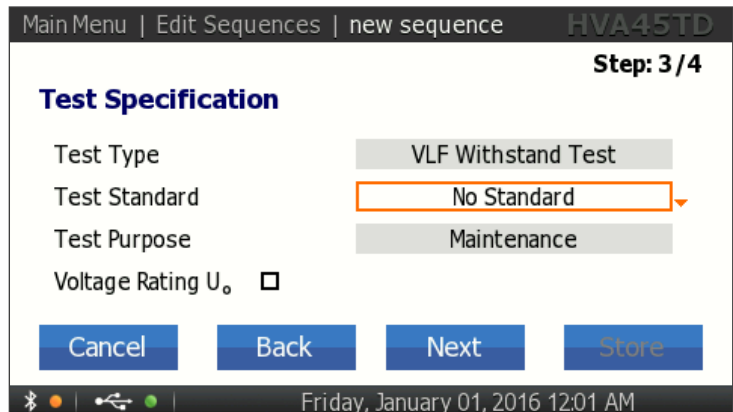

Test specification: Test purpose

Select appropriate test purpose:

- Maintenance
- Acceptance
- Installation

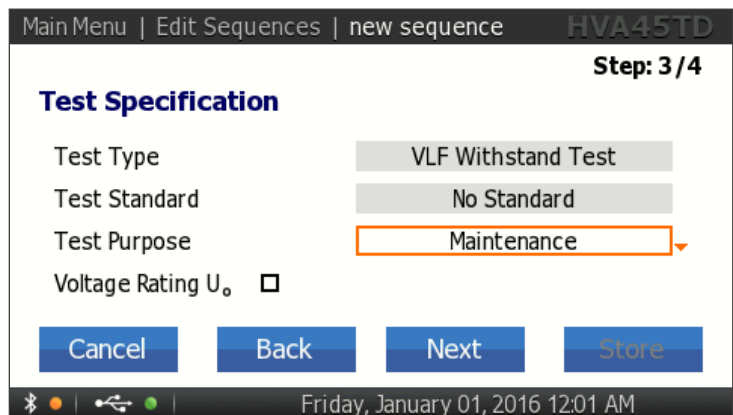

Test specification: U₀

Check this box, if you want to refer to the voltage rating U₀ for definition of the test step voltage. Depending on the DUT type, determine whether to use a three-phase calculation or a one-phase calculation of U₀. Based on the U value, the device calculates a U₀ value that can be edited here.

To continue, press "Next" button.

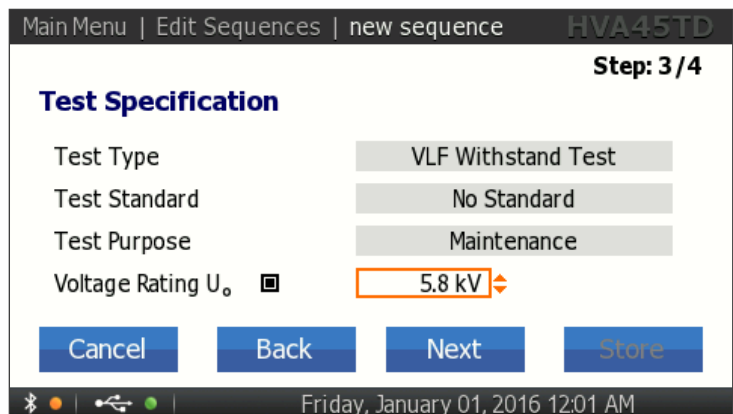

Test limits: Arc Management

Select an arc management mode.

- Trip out on Arc
- Burn on Arc

For Burn on arc mode only

fix the dwell time:

- Min. dwell time: 1 min
- Max. dwell time: 5 min

Main Menu | Edit Sequences | new sequence HVA45TD

Step: 4/4

Test Limits

| | | |
|----------------------------|-------------|---------|
| Arc Management Mode | Burn on Arc | 1 min ▲ |
| Overload during test | No Action | |
| Voltage not reached | No Action | |
| Min. Insulation Resistance | No Action | |

Cancel Back Next Store

Friday, January 01, 2016 12:01 AM

Test limits: Overload

Set action to be taken in case of overload:

- No Action (default)
- Fail: Runs to end
- Fail: Immediate Stop

Main Menu | Edit Sequences | new sequence HVA45TD

Step: 4/4

Test Limits

| | | |
|----------------------------|-------------|-------|
| Arc Management Mode | Burn on Arc | 1 min |
| Overload during test | No Action ▼ | |
| Voltage not reached | No Action | |
| Min. Insulation Resistance | No Action | |

Cancel Back Next Store

Friday, January 01, 2016 12:01 AM

Test limits: Voltage not reached

Set action to be taken in case of overload:

- No Action (default)
- Fail: Runs to end
- Fail: Immediate Stop

Main Menu | Edit Sequences | new sequence HVA45TD

Step: 4/4

Test Limits

| | | |
|----------------------------|---------------------|-------|
| Arc Management Mode | Burn on Arc | 1 min |
| Overload during test | No Action | |
| Voltage not reached | Fail: Immed. Stop ▲ | |
| Min. Insulation Resistance | No Action | |

Cancel Back Next Store

Friday, January 01, 2016 12:01 AM

Test limits: Min. insul. resistance

Set action to be taken in case minimum insulation resistance is reached:

- No Action (default)
- Fail: Runs to end
- Fail: Immediate Stop

The resistance value can be set in the box beside the action.

To store the sequence, press the "Store" button. Store

Main Menu | Edit Sequences | new sequence HVA45TD

Step: 4/4

Test Limits

| | | |
|----------------------------|-------------------|---------|
| Arc Management Mode | Burn on Arc | 1 min |
| Overload during test | No Action | |
| Voltage not reached | Fail: Immed. Stop | |
| Min. Insulation Resistance | Fail: Runs to end | 10 MΩ ▲ |

Cancel Back Next Store

Friday, January 01, 2016 12:01 AM

The sequence which you have just configured is going to be added to the list with sequences, under a title you specified in step: 1/4. After you have stored the test sequence the HVA will show you an overview of the sequence where you can check and edit the settings. There you can also edit the test parameters for the different voltage steps. See 6.4.2 Modifying an existing auto test sequence on the next pages for further information.

6.4.2 Modifying an existing auto test sequence

In order to modify an existing sequence, there must already be some sequences / a sequence available in the "Edit Sequences" menu. It can then be overwritten according to the following procedure:

Edit Sequences menu

To modify an existing sequence, we start at the "Edit Sequences" menu.

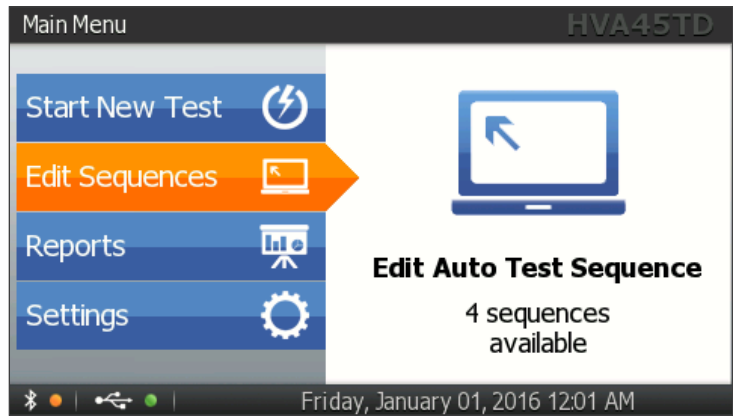

Edit an existing sequence

Pick a sequence from the list and on the right side, click on the "Edit" button.

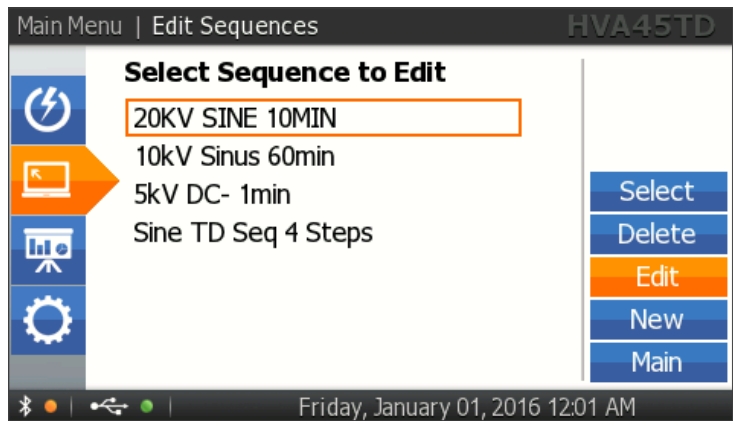

Sequence info: Title

Activate the keyboard and edit the title for your new sequence.

Later, the new sequence will appear in the list of available sequences under this title.

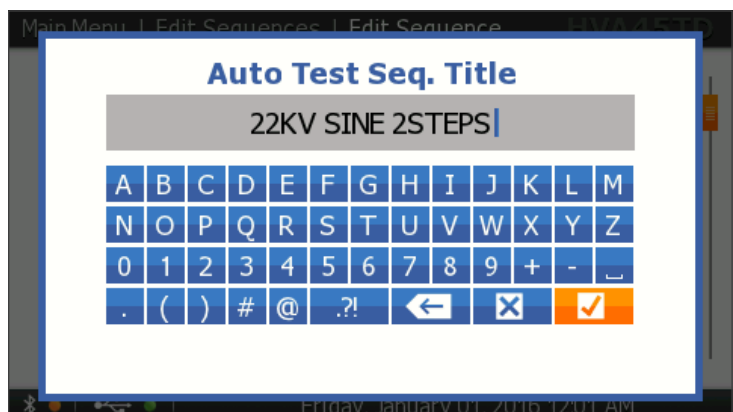
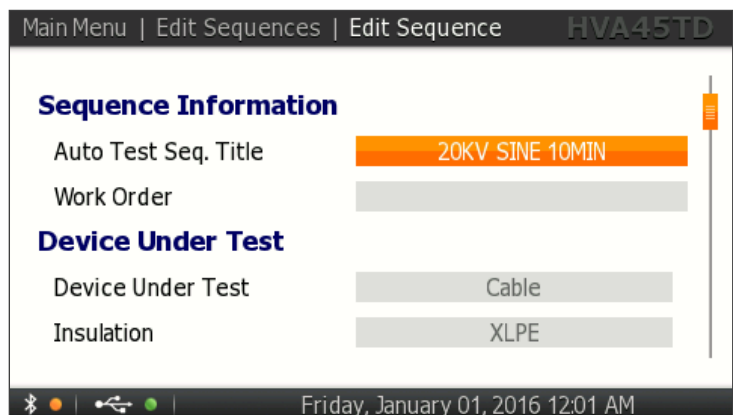

The next parameters are identical to the ones introduced in chapter 6.4.1 Configuring a new auto test sequence, steps 1 through 4.

Thus, below we continue with the parameters which were not discussed in the mentioned chapter. The parameters we skip here are identical with the ones mentioned in the chapter 6.4.1 Configuring a new auto test sequence. These parameters are:

- DUT: Cable,
- Test type: VLF Withstand test,
- Test standard: No standard.

Test parameters: Period count

This parameter is dependent on selection of the standard.

- ... test duration in: [time]
- ... test duration in: [samples or periods]

In some standards, the test duration units are predetermined (i.e.: IEEE).

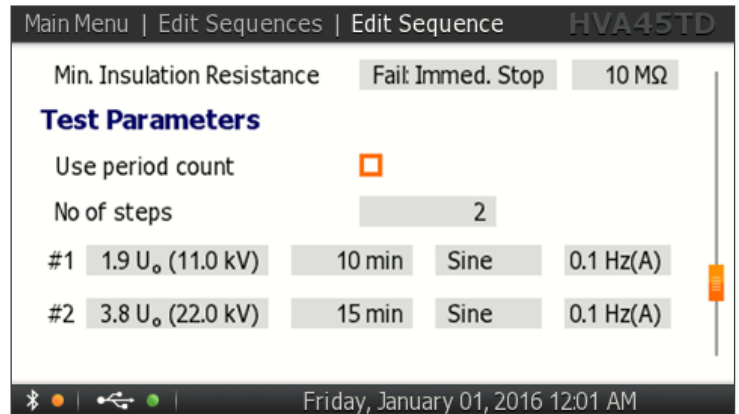

Test parameters: # of U steps

Specify the number of voltage steps to be applied to the DUT.

- Min. step count: 1 step
- Max. step count: 15 steps

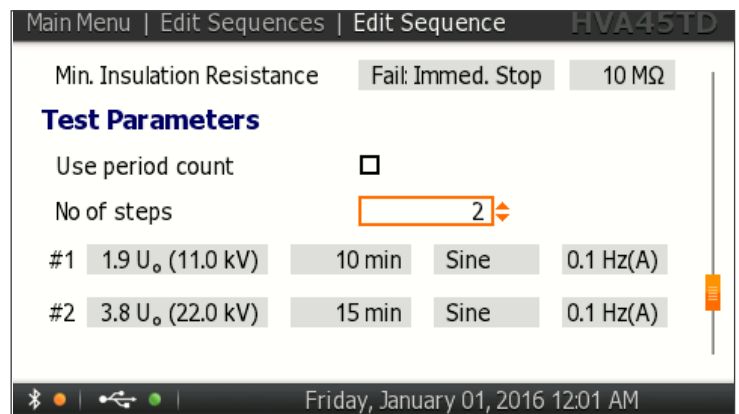

Test parameters: Test voltage

For each step, specify the test voltage.

- Min. voltage level: 0,1kV or 0,1U₀
- Max. voltage is dependent on the maximal test set voltage

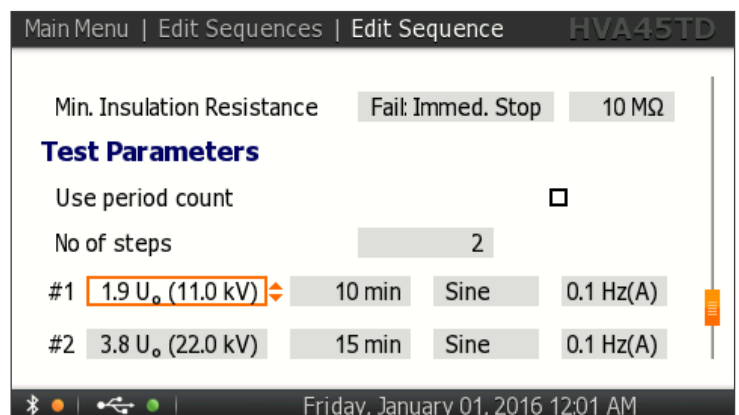

Test parameters: Test duration

For each step, specify the test duration:

- For **non-Tan Delta** test types you continue with **periods**.
- For **Tan Delta** tests you continue with **samples**.

The testing time depends on the frequency chosen.

- Min. 1 min
- Max. 24h 0 min

Sampling range: 2 to 500

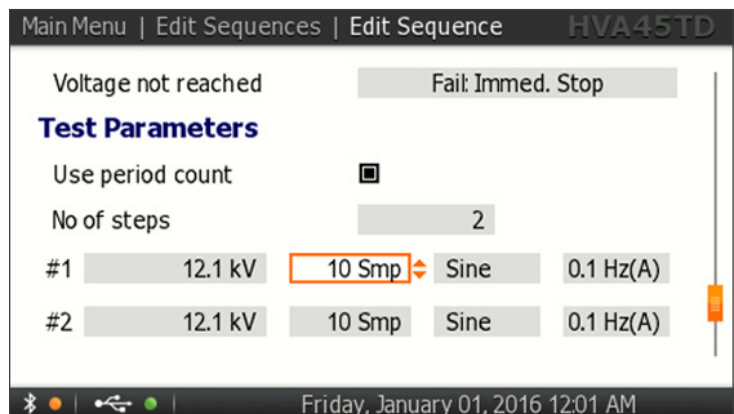
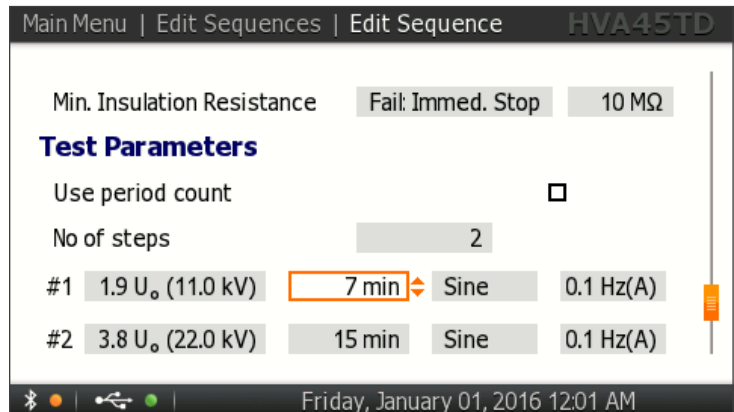

Test parameters: Waveform

For specific output modes following waveforms are available:

VLF withstand test

- Sine wave
- Square wave

VLF Tan Delta test

- Sine wave

DC test

- DC+
- DC-
- DC for a vacuum bottle test

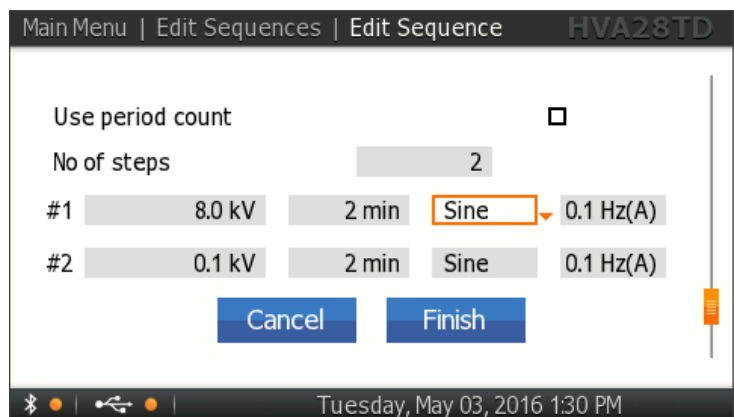

Test parameters: Frequency

For each step, set the frequency value. Choose between these options:

- 0.1 Hz(A): recommended setting that automatically maintains the frequency as close to 0.1 Hz as possible.
- fixed frequency can be set from 0.01 Hz to 0.1 Hz in steps of 0.01 Hz.

To store the sequence, press the "Finish" button.

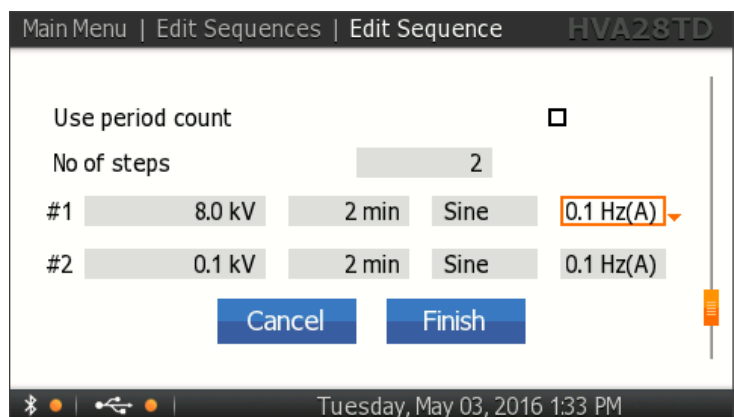

6.5 Interrupting a test

Once a test has started, it can be interrupted at any time. It is recommended to choose the appropriate interruption method for the situation.

Routine stop - standard

Throughout the duration of the test, the "STOP" symbol is highlighted on the right-hand side of the screen footer.

If you wish to interrupt the test, push in the navigation knob **41**.

- HVA software deactivates HV.
- Test stops.

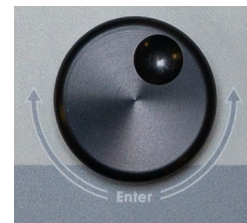
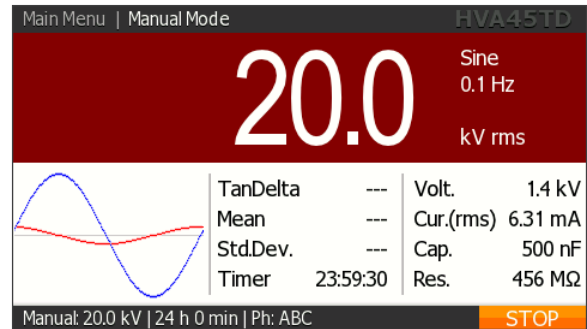

Routine stop - alternative

While the test is in progress, you can deactivate high voltage by pressing the HV switch **40**.

- HVA hardware deactivates HV.
- Test stops.



Emergency stop

In an emergency situation, at any time, press the "Emergency OFF" button **42** to shut-down the system.

- HVA hardware deactivates HV.
- Test stops.



6.6 Discharge status

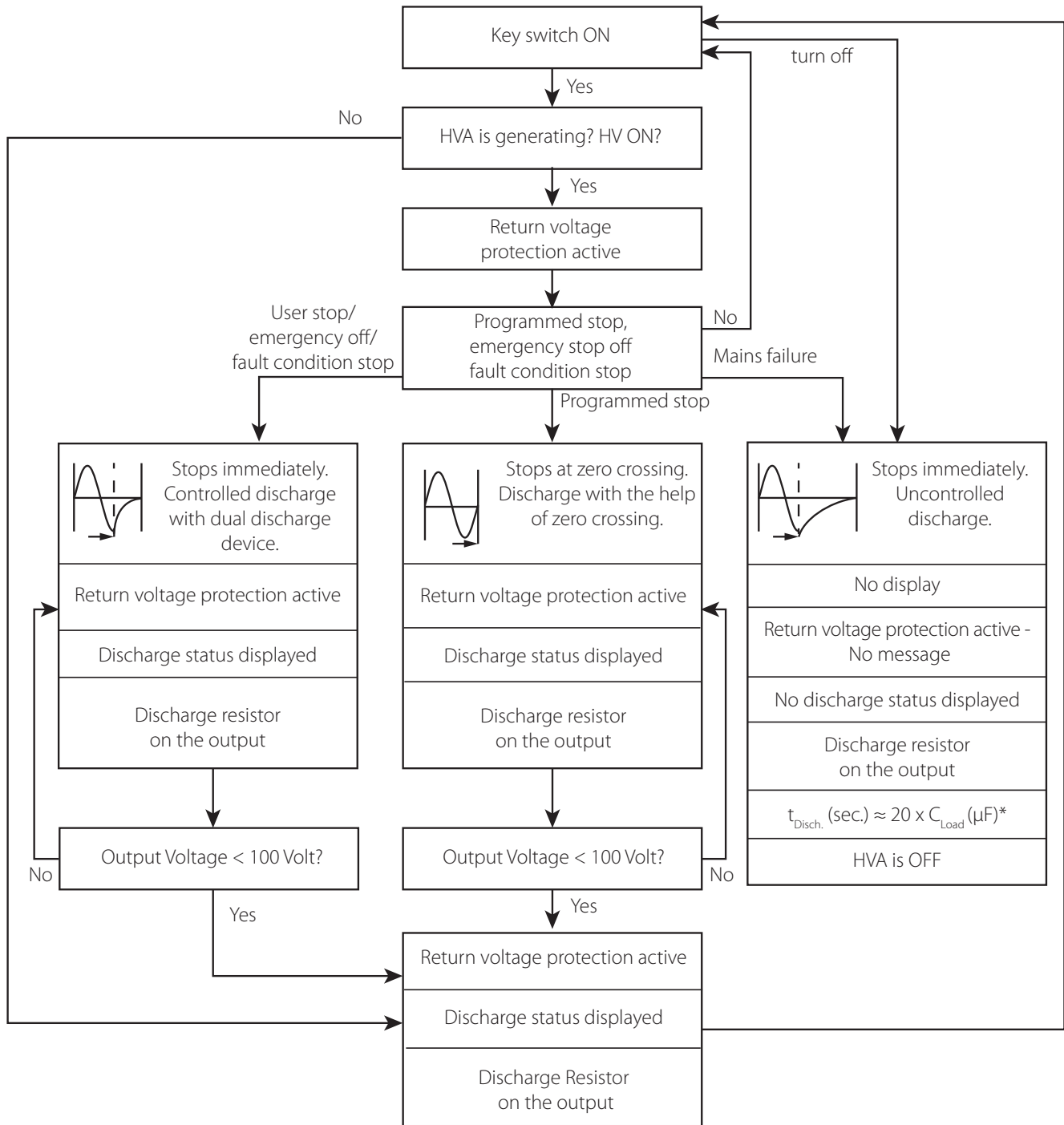

* Discharge time approximation: $t_{\text{Discharge}} \text{ (sec.)} \approx 20 \frac{\text{s}}{\mu\text{F}} \times C_L \text{ (}\mu\text{F)}$

Example: Load capacitance $C_L = 1.2 \mu\text{F}$. $t_{\text{Discharge}} \approx 20 \times 1.2 = 24 \text{ sec.}$

This is an approximation only and does not replace the safety rules.

7 Reporting

7.1 Report types

All HVA test sets from the smartVLF® series generate two report types: "Basic" or "Extended". Reporting can also be disabled. Set your reporting choice under **Settings / Instrument Setup / Reporting** or go to 4.2.1 Instrument Setup, step IS5: Reporting for further information.

Following report information is available for each of the mentioned reporting options:

| Report information | Basic reporting | Extended reporting | Disabled reporting |
|--|-----------------|--------------------|--------------------|
| Report title | ✓ | ✓ | – |
| Device under test | ✓ | ✓ | – |
| Voltage rating [kV] | ✓ | ✓ | – |
| Insulation | ✓ | ✓ | – |
| Propagation velocity (v) *only for test sets with APL functionality | ✓ | ✓ | – |
| Phase | ✓ | ✓ | – |
| Company name | – | ✓ | – |
| Region name | – | ✓ | – |
| Station name | – | ✓ | – |
| Line length [m/ft] | – | ✓ | – |
| Size of DUT | – | ✓ | – |
| Manufacturer name | – | ✓ | – |
| Work order | – | ✓ | – |
| Operator name | – | ✓ | – |

7.2 Reporting parameters

In following pages, every report information from the previous page is described in further detail.

Please note that line with propagation velocity ("Propag. velocity (v)") is depicted only on the test sets with APL functionality.

Report title: Basic & Extended

Give your report a suitable title.
For more information on how to type in the characters, please go to 4.1.3 Operating the keyboard section.

Main Menu | Start a New Test | Report Details HVA68TD

| | |
|----------------------|------------|
| Report Title | TEST3 |
| Device Under Test | Cable |
| Voltage Rating | 2.0 kV |
| Insulation | XLPE |
| Propag. velocity (v) | 160.0 m/μs |
| Phase | A |

Back Next

Thursday, November 30, 2023 12:52 PM b2

Main Menu | Start a New Test | Report Details HVA68TD

Report Title

TEST3|

| | | | | | | | | | | | | |
|---|---|---|---|---|-----|---|---|---|---|---|---|---|
| A | B | C | D | E | F | G | H | I | J | K | L | M |
| N | O | P | Q | R | S | T | U | V | W | X | Y | Z |
| 0 | 1 | 2 | 3 | 4 | 5 | 6 | 7 | 8 | 9 | + | - | ↵ |
| . | (|) | # | @ | .?! | ← | ✕ | ✓ | | | | |

Thursday, November 30, 2023 12:49 PM b2

DUT: Basic & Extended

Set the device to be tested.
The options are:

- Cable
- Motor
- Generator
- Transformer
- Switchgear
- Vacuum Bottle
- Other

Main Menu | Start a New Test | Report Details HVA68TD

| | |
|----------------------|------------|
| Report Title | TEST3 |
| Device Under Test | Cable |
| Voltage Rating | 2.0 kV |
| Insulation | XLPE |
| Propag. velocity (v) | 160.0 m/μs |
| Phase | A |

Back Next

Thursday, November 30, 2023 12:54 PM b2

Voltage rating: Basic & Extended

The possible range is 0 to 50 kV.

Remark:

This is a characteristic of the DUT.
Based on this value we can then calculate U_0 .

Main Menu | Start a New Test | Report Details HVA68TD

| | |
|----------------------|------------|
| Report Title | TEST3 |
| Device Under Test | Cable |
| Voltage Rating | 10.0 kV |
| Insulation | XLPE |
| Propag. velocity (v) | 160.0 m/μs |
| Phase | A |

Back Next

Thursday, November 30, 2023 12:56 PM b2

Insulation: Basic & Extended

Set the cable insulation type:

- XLPE
- TRXLPE
- PILC
- EPR
- EPR (black)
- EPR (pink)
- EPR (dis. res.)
- PE
- PVC
- HYBR

Main Menu | Start a New Test | Report Details HVA68TD

| | |
|----------------------|------------|
| Report Title | TEST3 |
| Device Under Test | Cable |
| Voltage Rating | 10.0 kV |
| Insulation | XLPE |
| Propag. velocity (v) | 160.0 m/μs |
| Phase | A |

Thursday, November 30, 2023 1:04 PM b2

Propag. velocity: Basic & Ext.

This characteristics is available only for DUT: Cable and appears only on test sets with APL functionality.

Set propagation velocity of the DUT.
Default value: $v=160.0 \text{ m}/\mu\text{s}$

This value influences directly the accuracy of the Arc Pre-Location result. The more accurately the propagation velocity is entered, the more accurate the Arc Pre-Location will be.

Main Menu | Start a New Test | Report Details HVA68TD

| | |
|----------------------|------------|
| Report Title | TEST3 |
| Device Under Test | Cable |
| Voltage Rating | 10.0 kV |
| Insulation | XLPE |
| Propag. velocity (v) | 160.0 m/μs |
| Phase | A |

Thursday, November 30, 2023 1:06 PM b2

Phase: Basic & Extended

Set the phase:

- A
- B
- C
- AB
- AC
- BC
- ABC

Main Menu | Start a New Test | Report Details HVA68TD

| | |
|----------------------|------------|
| Report Title | TEST3 |
| Device Under Test | Cable |
| Voltage Rating | 10.0 kV |
| Insulation | XLPE |
| Propag. velocity (v) | 160.0 m/μs |
| Phase | ABC |

Thursday, November 30, 2023 1:10 PM b2



NOTICE

Further reporting information is available only for the extended reporting. If you wish to extend the report with more information, make sure you set the reporting choice under **Settings / Instrument Setup / Reporting** as "Extended".

Company name: Extended

Type in the company name.

Remark:
This field is only optional.

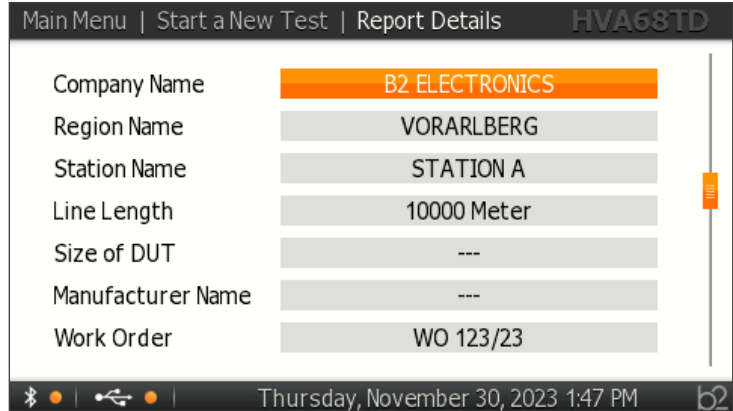

Region name: Extended

Type in the region name.

Remark:
This field is only optional.

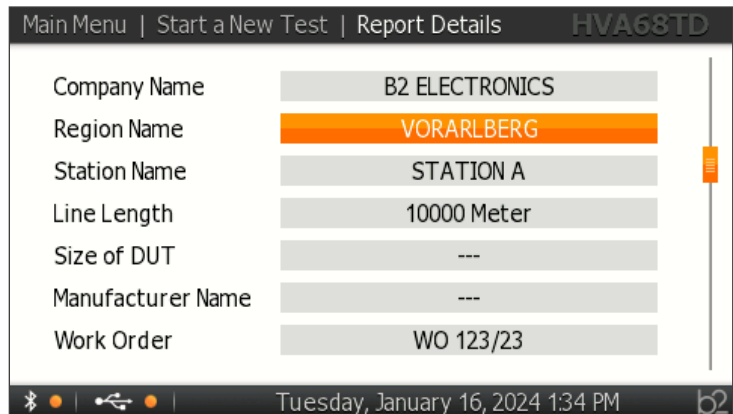

Station name: Extended

Type in the station name.

Remark:
This field is only optional.

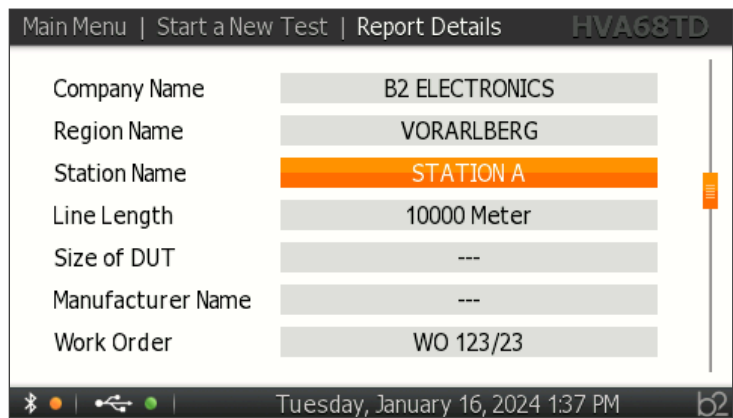

Line length: Extended

Set line length:
Default value is set to 10.000 m.

The entered value helps to narrow down the APL algorithm to identify the location of the arc. Specifying a line length also helps the APL to determine more precise results. Make sure the entered value is not smaller than the actual cable length.

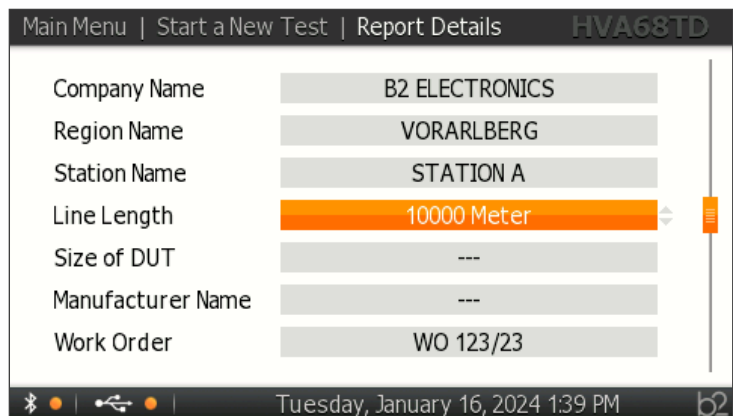

Size of DUT: Extended

Type in the size of the DUT.

Remark:
This field is only optional.

Main Menu | Start a New Test | Report Details HVA68TD

| | |
|-------------------|-------------|
| Station Name | STATION A |
| Line Length | 10000 Meter |
| Size of DUT | |
| Manufacturer Name | STU XYZ |
| Work Order | WO 123/23 |
| Operator Name | ALEX |

Back Next

Tuesday, January 16, 2024 1:47 PM

Manufacturer name: Extended

Type in the manufacturer name.

Remark:
This field is only optional.

Main Menu | Start a New Test | Report Details HVA68TD

| | |
|-------------------|-------------|
| Station Name | STATION A |
| Line Length | 10000 Meter |
| Size of DUT | |
| Manufacturer Name | STU XYZ |
| Work Order | WO 123/23 |
| Operator Name | ALEX |

Back Next

Tuesday, January 16, 2024 1:59 PM

Work order: Extended

Type in the work order.

Remark:
This field is only optional.

Main Menu | Start a New Test | Report Details HVA68TD

| | |
|-------------------|-------------|
| Station Name | STATION A |
| Line Length | 10000 Meter |
| Size of DUT | |
| Manufacturer Name | STU XYZ |
| Work Order | WO 123/23 |
| Operator Name | ALEX |

Back Next

Tuesday, January 16, 2024 2:00 PM

Operator name: Extended

Type in the operator name.

Remark:
This field is only optional.

Main Menu | Start a New Test | Report Details HVA68TD

| | |
|-------------------|-------------|
| Station Name | STATION A |
| Line Length | 10000 Meter |
| Size of DUT | |
| Manufacturer Name | STU XYZ |
| Work Order | WO 123/23 |
| Operator Name | ALEX |

Back Next

Tuesday, January 16, 2024 2:01 PM

7.3 Test report examples

On these two examples we would like to demonstrate the difference between the information included in **the extended reporting** (left) and **the basic reporting** (right).

Remark:

The information written in red and green regards distance to arc measurement possibility and is available for test sets with APL functionality only. If the test did not finish successfully, the information on arc location is always red, regardless the SCF value.

TD TEST 1
 VLF Diagnostic Report
 Sine TD Seq 4 Steps - Maintenance Test
 Auto Test
 Test failed - Arc location: 3206 m

Report Information

| | |
|---------------|-------------------|
| Date | 12/5/2023 8:53 AM |
| Company Name | B2 ELECTRONICS |
| Region | VORARLBERG |
| Station | STATION A |
| Operator Name | ALEX |
| Work Order | WO 123/23 |

Device Under Test (Cable XLPE)

| | |
|----------------------|-------------|
| Voltage Rating | 10.0 kV |
| Insulation | XLPE |
| Propag. velocity (v) | 160.0 m/μs |
| Line Length | 10000 Meter |
| Size | --- |
| Phase | ABC |
| Manufacturer Name | --- |

Equipment:

| | |
|---------|---------------|
| HVA68TD | GH5250.21Z012 |
|---------|---------------|

Test Setup

| | |
|---------------------|-----------------|
| Test Purpose | Maintenance |
| Arc Management Mode | Trip out on Arc |

| # | Test Voltage | Waveform | Frequency | Samples |
|---|--------------|----------|------------|---------|
| 1 | 5.0 kV* | Sine | 0.1 Hz (A) | 6 |
| 2 | 10.0 kV* | Sine | 0.1 Hz (A) | 6 |
| 3 | 15.0 kV* | Sine | 0.1 Hz (A) | 6 |
| 4 | 25.3 kV* | Sine | 0.1 Hz (A) | 6 |

Measurements:
 failed at step 4 after 0 Samples
 interrupted by Arc at 24.3 kV

| # | Voltage | Current | Cap. | Res. | Frequency |
|---|----------|----------|--------|--------|-----------|
| 1 | 5.0 kV* | 1.57 mA* | 500 nF | 1.8 GΩ | 0.1 Hz |
| 2 | 10.0 kV* | 3.14 mA* | 500 nF | 1.8 GΩ | 0.1 Hz |
| 3 | 15.0 kV* | 4.71 mA* | 500 nF | 1.8 GΩ | 0.1 Hz |
| 4 | 15.0 kV* | 4.71 mA* | --- | --- | 0.1 Hz |

| # | Voltage | TD [E-3] | Std.Dev. [E-3] |
|---|----------|----------|----------------|
| 1 | 5.0 kV* | 2.73 | 0.01 |
| 2 | 10.0 kV* | 2.73 | 0.01 |
| 3 | 15.0 kV* | 2.82 | 0.01 |
| 4 | 15.0 kV* | --- | 1000.0 |

*RMS value

Arc Pre-Location

| # | Distance | SCF |
|---|----------|-----|
| 1 | 3206 m | 7.6 |

TD TEST 11
 VLF Diagnostic Report
 Sine TD Seq 4 Steps - Maintenance Test
 Auto Test
 Test failed - Arc location: 3206 m

Report Information

| | |
|------|-------------------|
| Date | 12/5/2023 9:59 AM |
|------|-------------------|

Device Under Test (Cable XLPE)

| | |
|----------------------|------------|
| Voltage Rating | 10.0 kV |
| Insulation | XLPE |
| Propag. velocity (v) | 160.0 m/μs |
| Phase | ABC |

Equipment:

| | |
|---------|---------------|
| HVA68TD | GH5250.21Z012 |
|---------|---------------|

Test Setup

| | |
|---------------------|-----------------|
| Test Purpose | Maintenance |
| Arc Management Mode | Trip out on Arc |

| # | Test Voltage | Waveform | Frequency | Samples |
|---|--------------|----------|------------|---------|
| 1 | 5.0 kV* | Sine | 0.1 Hz (A) | 6 |
| 2 | 10.0 kV* | Sine | 0.1 Hz (A) | 6 |
| 3 | 15.0 kV* | Sine | 0.1 Hz (A) | 6 |
| 4 | 25.3 kV* | Sine | 0.1 Hz (A) | 6 |

Measurements:
 failed at step 4 after 0 Samples
 interrupted by Arc at 24.0 kV

| # | Voltage | Current | Cap. | Res. | Frequency |
|---|----------|----------|--------|--------|-----------|
| 1 | 5.0 kV* | 1.57 mA* | 500 nF | 1.8 GΩ | 0.1 Hz |
| 2 | 10.0 kV* | 3.14 mA* | 500 nF | 1.8 GΩ | 0.1 Hz |
| 3 | 15.0 kV* | 4.71 mA* | 500 nF | 1.8 GΩ | 0.1 Hz |
| 4 | 0.0 kV* | 0.0 μA* | --- | --- | --- |

| # | Voltage | TD [E-3] | Std.Dev. [E-3] |
|---|----------|----------|----------------|
| 1 | 5.0 kV* | 2.73 | 0.01 |
| 2 | 10.0 kV* | 2.73 | 0.01 |
| 3 | 15.0 kV* | 2.82 | 0.01 |
| 4 | 0.0 kV* | --- | 1000.0 |

*RMS value

Arc Pre-Location

| # | Distance | SCF |
|---|----------|-----|
| 1 | 3206 m | 7.6 |

On these two examples we would like to demonstrate the difference between the reports when **test finished successfully** (left) and when **test failed** (right).

Remark:

The information written in red and green regards distance to arc measurement possibility and is available for test sets with APL functionality only.

| TEST5 | | | | | |
|--------------------------------|--------------------|----------|------------|----------|-----------|
| VLF Withstand Report | | | | | |
| Manual Test | | | | | |
| Test finished successfully | | | | | |
| Report Information | | | | | |
| Date | 11/30/2023 2:35 PM | | | | |
| Company Name | B2 ELECTRONICS | | | | |
| Region | VORARLBERG | | | | |
| Station | STATION A | | | | |
| Operator Name | ALEX | | | | |
| Work Order | WO 123/23 | | | | |
| Device Under Test (Cable XLPE) | | | | | |
| Voltage Rating | 10.0 kV | | | | |
| Insulation | XLPE | | | | |
| Propag. velocity (v) | 160.0 m/μs | | | | |
| Line Length | 10000 Meter | | | | |
| Size | --- | | | | |
| Phase | ABC | | | | |
| Manufacturer Name | --- | | | | |
| Equipment: | | | | | |
| HVA68TD | GH5250.21Z012 | | | | |
| Test Setup | | | | | |
| Arc Management Mode | Trip out on Arc | | | | |
| # | first Voltage | Waveform | Frequency | Duration | |
| 1 | 15.0 kV* | Sine | 0.1 Hz (A) | 1 min | |
| Manual max. Voltage 15.0 kV | | | | | |
| Measurements: | | | | | |
| Test finished successfully | | | | | |
| # | Voltage | Current | Cap. | Res. | Frequency |
| 1 | 15.0 kV* | 1.11 mA* | 118 nF | 966 MΩ | 0.1 Hz |
| *RMS value | | | | | |

| TEST7 | | | | | |
|--|--------------------|----------|------------|----------|-----------|
| VLF Withstand Report | | | | | |
| Manual Test | | | | | |
| Test failed - Arc location: 3206 m | | | | | |
| Report Information | | | | | |
| Date | 11/30/2023 2:41 PM | | | | |
| Company Name | B2 ELECTRONICS | | | | |
| Region | VORARLBERG | | | | |
| Station | STATION A | | | | |
| Operator Name | ALEX | | | | |
| Work Order | WO 123/23 | | | | |
| Device Under Test (Cable XLPE) | | | | | |
| Voltage Rating | 10.0 kV | | | | |
| Insulation | XLPE | | | | |
| Propag. velocity (v) | 160.0 m/μs | | | | |
| Line Length | 10000 Meter | | | | |
| Size | --- | | | | |
| Phase | ABC | | | | |
| Manufacturer Name | --- | | | | |
| Equipment: | | | | | |
| HVA68TD | GH5250.21Z012 | | | | |
| Test Setup | | | | | |
| Arc Management Mode | Trip out on Arc | | | | |
| # | first Voltage | Waveform | Frequency | Duration | |
| 1 | 0.0 kV* | Sine | 0.1 Hz (A) | 1 h | |
| Manual max. Voltage 20.8 kV | | | | | |
| Measurements: | | | | | |
| failed at step 1 after 0 min 13 sec interrupted by Arc at 24.6 kV | | | | | |
| # | Voltage | Current | Cap. | Res. | Frequency |
| 1 | 0.0 kV* | 0.0 μA* | --- | --- | 0.1 Hz |
| *RMS value | | | | | |
| Arc Pre-Location | | | | | |
| # | Distance | SCF | | | |
| 1 | 3206 m | 7.6 | | | |

When the test fails on the HVA68TD test set, there are more options how the test report will be depicted:

- test failed, correlation factor for calculating a pre-location of the arc is high**
 Test report to this situation is depicted on the right side; information on the result is written in red and the detected Arc Pre-Location in green.
- test failed, correlation factor is just moderate**
 Test report to this situation is very similar to the one on the right side; information on the result is written in red and the detected Arc Pre-Location is written in orange.
- test failed, arc was not able to locate**
 Test report to this situation is very similar to the one on the right side; however, there is no information on Arc Pre-Location at the top and at the bottom of the report.

7.4 Report management

Reports can be viewed directly on the HVA display and can be exported on a USB flash drive (see 4.2.4 Data administration for more details) or downloaded to b2 ControlCenter via Bluetooth. Below are the options how you can manage the created reports:

Reports main menu

From the main menu, select "Reports"

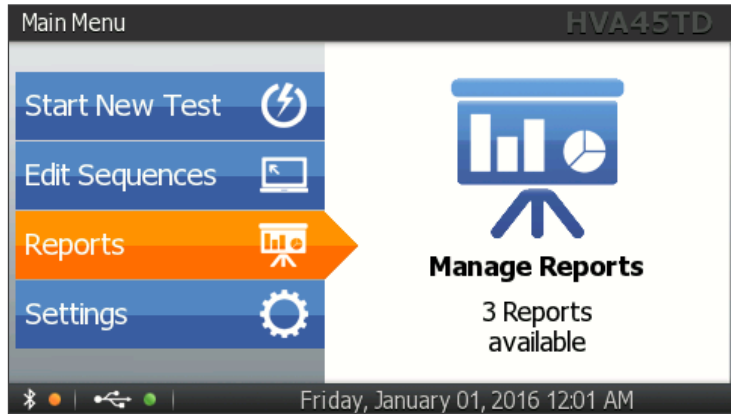

Select a report

Here, all available reports are listed. On the right side are blue tabs with all the possibilities that come with the selected report.

Select a report and confirm your selection with the "Select" button. Only then can you with this particular report use further options from the bar on the right.

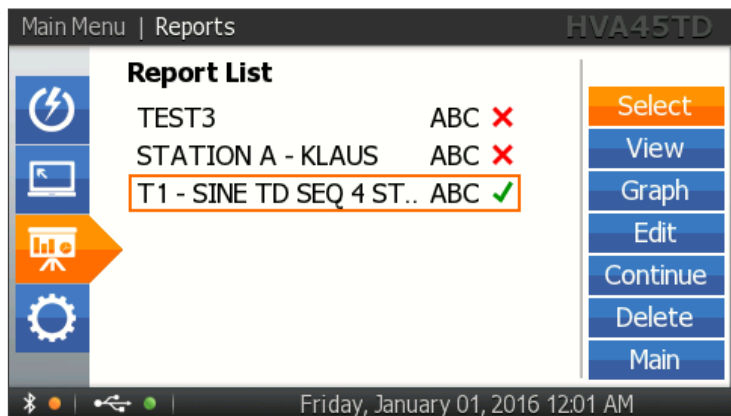

View a report

Select "View" for viewing the report on the HVA screen. The whole report appears, as shown on examples on previous two pages.



T1 - SINE TD SEQ 4 STEPS

VLF Diagnostic Report
Sine TD Seq 4 Steps - Maintenance Test
Auto Test
Test finished successfully

Report Information

| | |
|---------------|-------------------|
| Date | 1/1/2016 12:01 AM |
| Company Name | B2ELECTRONIC |
| Region | VLGB |
| Station | STATIONA |
| Operator Name | MAX |

View a graph

Select "Graph" for viewing the TD graph on the HVA screen. The name of the graph is the name of the report.

Remark:
Only possible, if you use a TD unit.

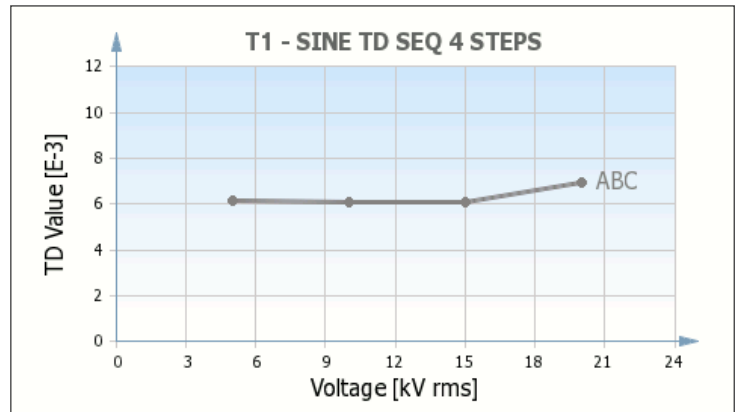
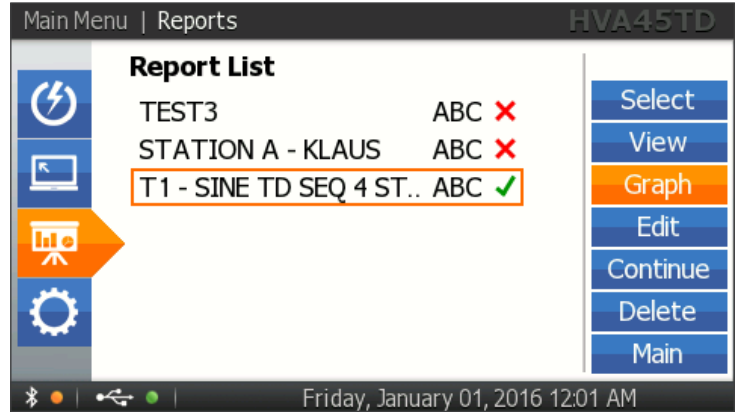

Edit a report

- the name of the report
- the phase of the report

The name of the report is edited via the keyboard. Go to chapter 4.1.3 Operating the keyboard, if you need more information on the use of the keyboard.

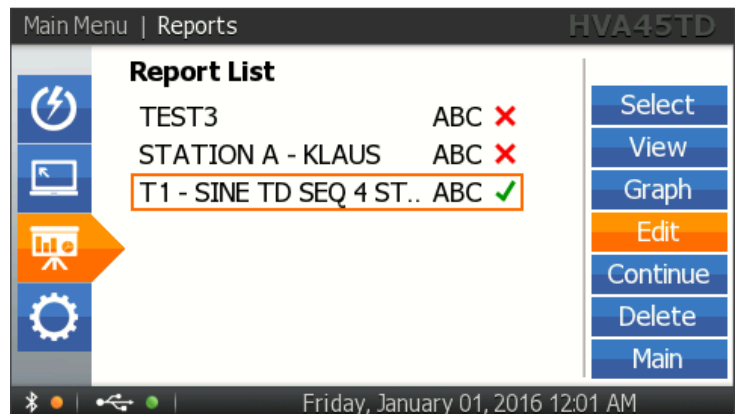

Edit a report - Report title

The name of the report is edited via the keyboard. Go to chapter 4.1.3 Operating the keyboard, if you need more information on the use of the keyboard.

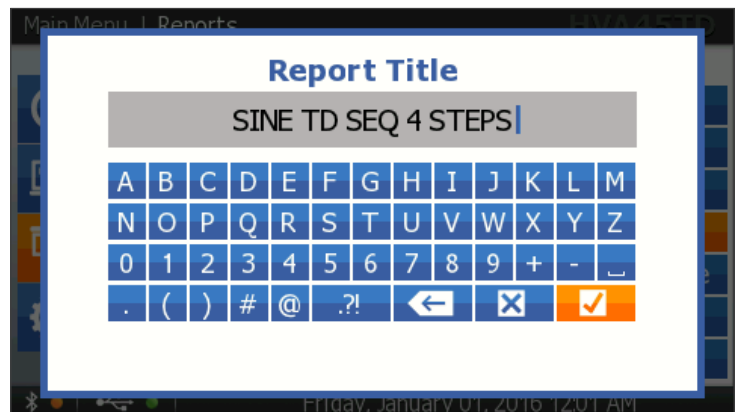

Edit a report - Change phase

To change a phase, select from the options available in the box next to "Phase" and confirm with OK.

An informative screen that the changes were stored successfully should appear next and confirm this operation.

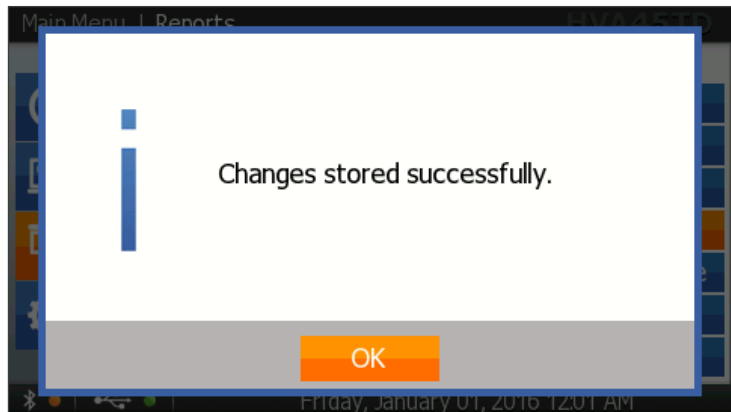
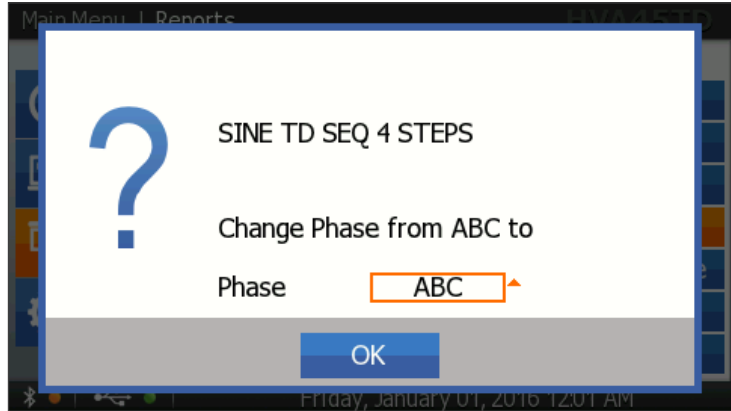

Continue with the measurement

Select "Continue" to continue with the measurement. First, select the phase to be tested. The phase last measured is indicated.

This functionality allows you to start a measurement on a three-phase system at one time and finish it later.

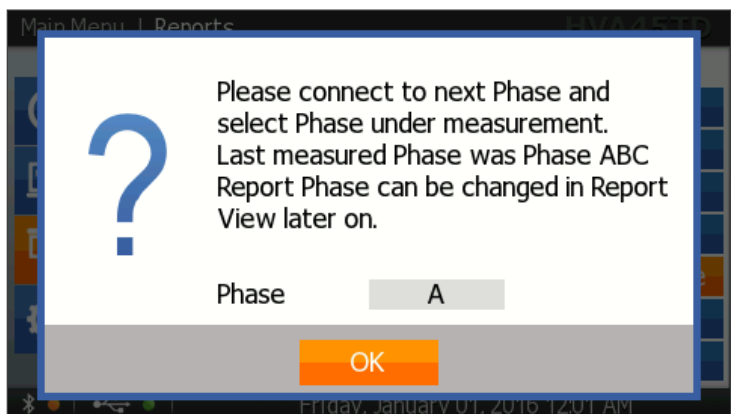
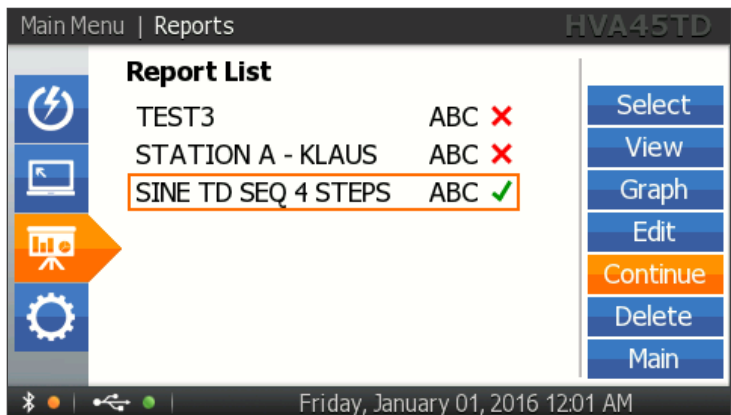

Delete a report

Select "Delete" for two delete options.

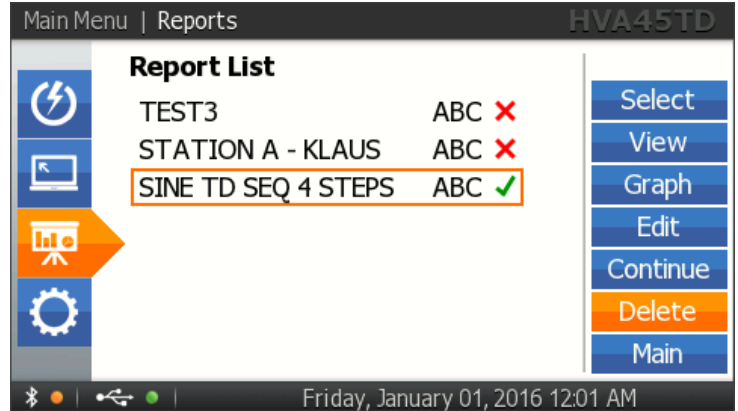

Delete a report - Delete All

If you select "Del All", the system is about to delete all stored reports. A second screen appears, asking you to confirm your action.

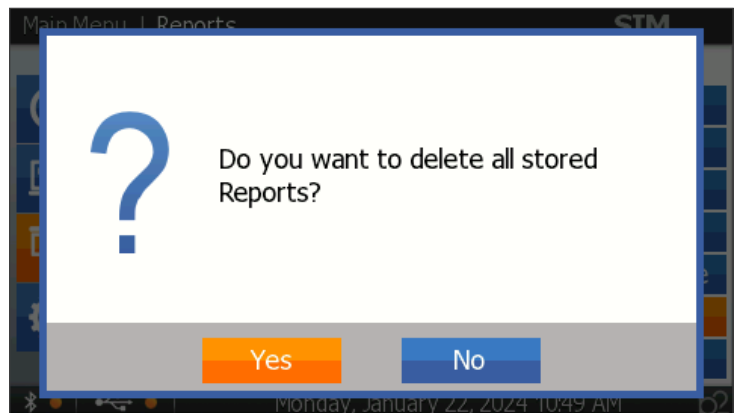
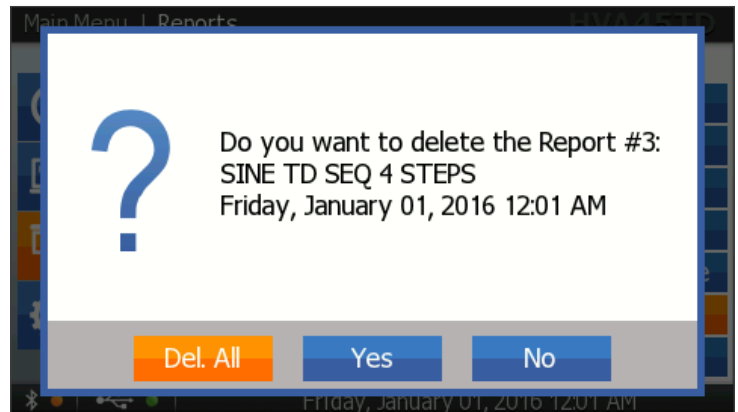

Delete a report - Yes

If you select "Yes", this particular report will be deleted.

Remark:
No further screen appears asking you to confirm your action.

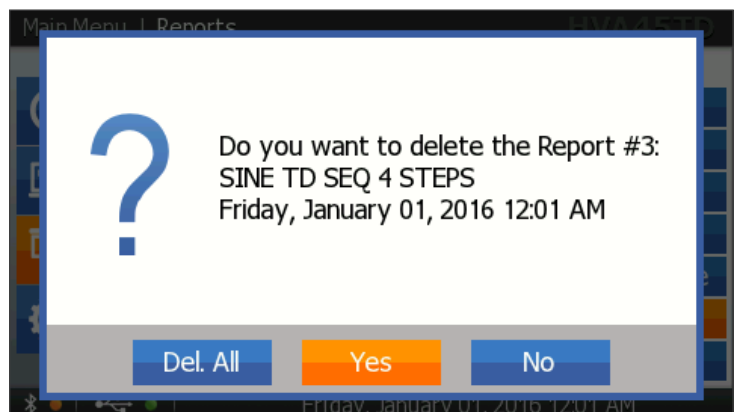

Delete a report - No

If you select "No", this report remains unharmed and report list screen with all available reports and options on the right side appears.

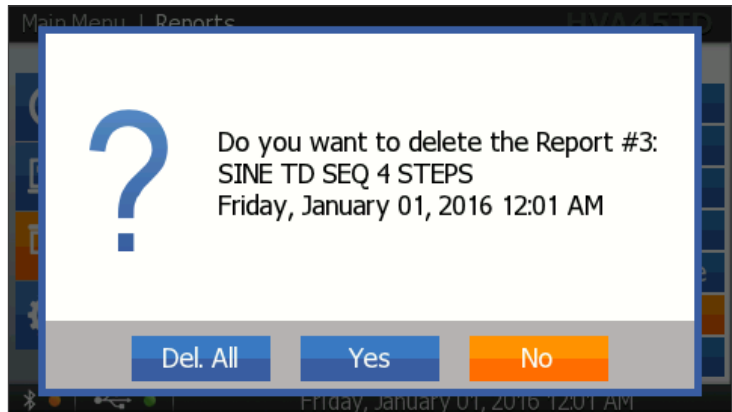

Main

If you don't plan to proceed any activity with the reports from the report list, press "Main" and return to the main menu.

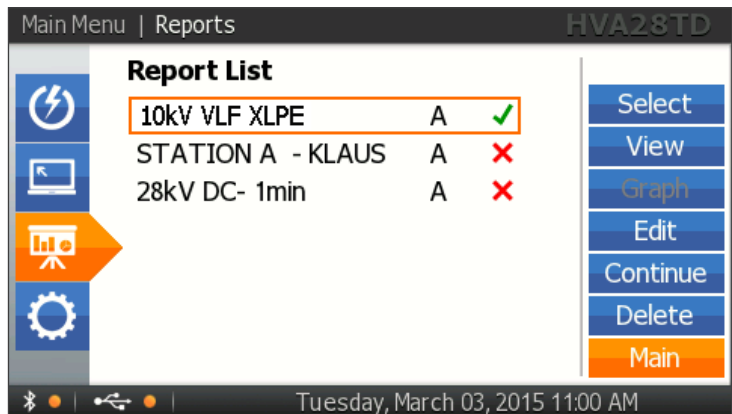

This page is intentionally left blank.

8 Disconnection procedure

DANGER

Electric shock hazard

Disconnection procedures must comply with local safety regulations. Make sure you obey the five safety rules in the order listed in chapter 2.1 on page 8!

- Cables must be connected according to the sequence below!
- Before disconnecting the test lead, DUT must be discharged and earthed!
- Earth connections must be removed last!

Disconnection diagrams:

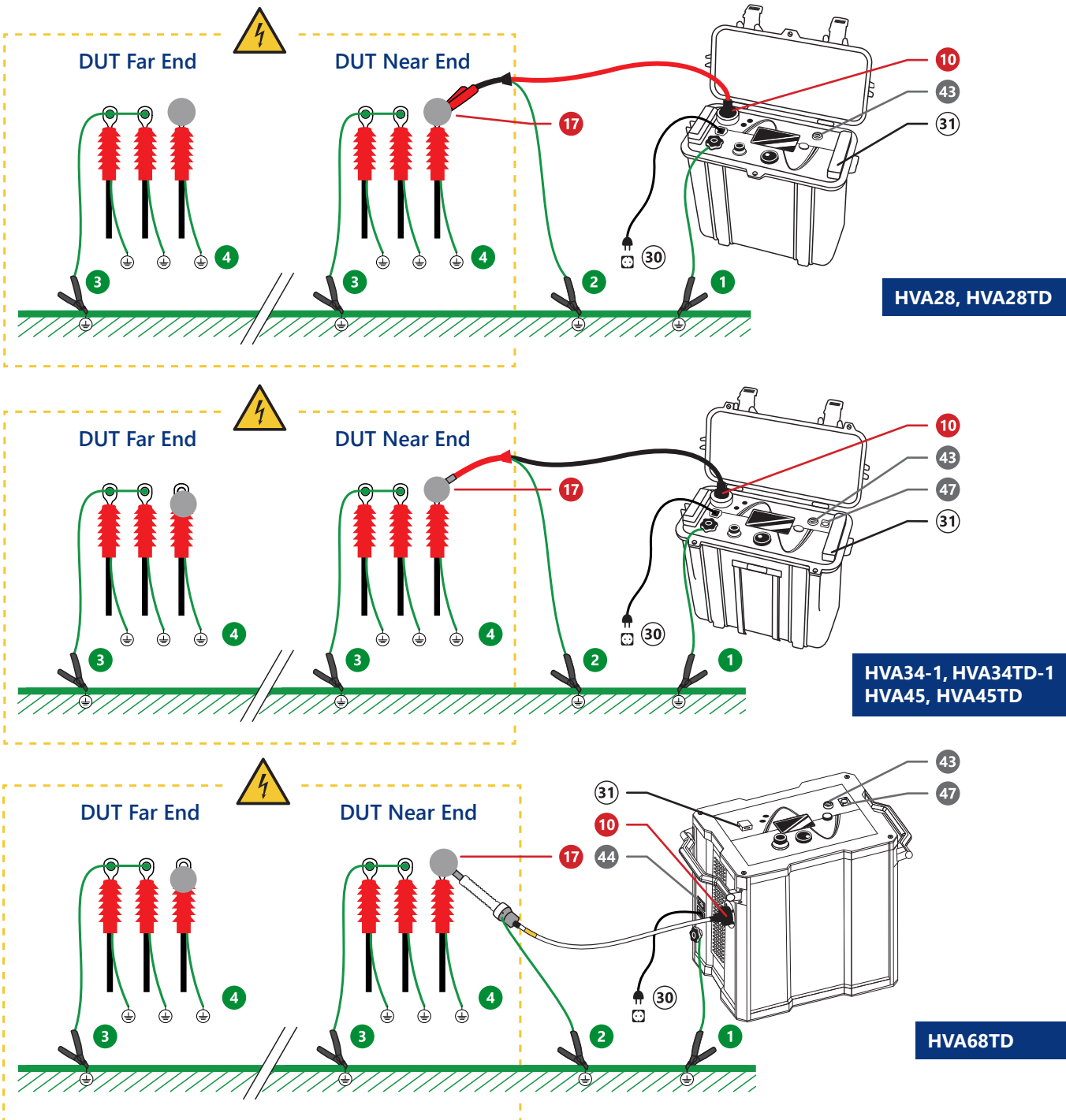

9 PC software

The HVA system is delivered with a set of Windows-based software tools in an integrated software package. The corresponding b2 ControlCenter software connects, records, analyses and reports the test results from the HVA testing instruments.

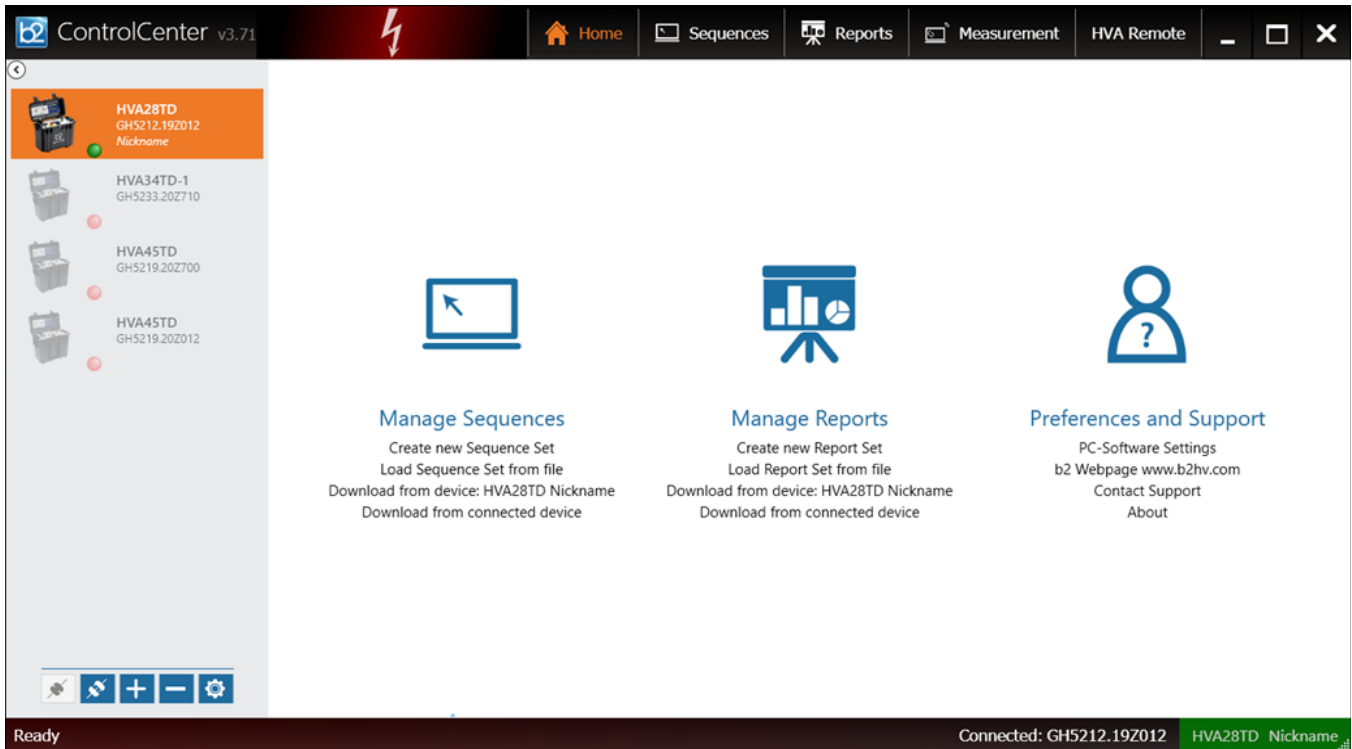

As was already discussed in chapter 4.1.4 Data transfer modes, if the HVA is connected to the b2 ControlCenter, reports and sequences can be downloaded from the HVA using the corresponding functions. See software manual for further information.

10 Additional information

10.1 Storage

Storage temperature: -25°C to +70°C

Humidity: 5 - 85% non-condensing

If the appliance is not to be used for a longer period of time, always store it in the packaging supplied.
If the appliance is stored open for shutdown and is heavily soiled, this can lead to malfunctions.

10.2 Apparatus care



DANGER

Electric Shock Hazard!

NEVER assume that equipment is safe to handle without using the necessary safety equipment and earthing procedures.

When cleaning **the equipment**, avoid spraying the control electrics directly with a high-pressure jet. If a high-pressure jet is used to clean electrical system components, this can lead to electrical faults and malfunctions.
If malfunctions are detected due to wet control electrics, operation must be stopped. Open the appliance and allow it to dry out completely. After resuming operation, check the function by running through the switch-on/switch-off procedure several times.

Clean the **HV cable / DUT adapters / test lead** connection points after use before storing.



NOTICE

Authorized personnel only!

Repairs and maintenance should only be performed by authorized b2 personnel. It is strictly prohibited to open the device and do any changes within the interior of the device.

Recommended inspection:
Annual inspection by authorised b2 staff is recommended.

10.3 Behavior at different unexpected conditions

In case of fire

If the appliance switches to a faulty state due to sparking and starts to burn, there is a risk of toxic gases being released by the burnt materials. In this case, the device has a software check that monitors the output voltage and switches it off.
Press the "Emergency OFF" button  immediately (see chapter 6.5 Interrupting a Test for more information) and disconnect the appliance from the mains. Extinguish the resulting fire with extinguishing agents approved for high-voltage technology.

If you are working in "Burn on arc" mode and the device does not switch off automatically after the pre-programmed dwell period, or after a user stop, there is a risk of sparking and fire. If such a situation is suspected, the appliance must be switched off immediately using the "Emergency OFF" button  (see chapter 6.5 Interrupting a test for more information) and disconnected from the mains.

In case of wet environment

Position the device so that it does not get wet due to the environment. If the device is set up in a wet environment or if the device is subjected to strong temperature changes in high humidity and becomes damp, this can lead to voltage flashovers: Danger to life.

When reaching dew point

Position the device so that it is not in humid environment. If the device is set up in such an environment or if the device is subjected to strong temperature changes in high humidity and becomes damp, this can lead to voltage flashovers: Danger to life. In the event of significant temperature changes with dew point formation, you must first allow the appliance to acclimatize until the moisture has completely dried out before you start commissioning.

In case of power outage

A power failure causes the visual display to go out and the operating status of the appliance to be recognized. However, the device automatically switches to a safe state.

If you in case of possible power outage decide to work with the generator, working with overvoltage during generator operation will destroy the appliance. Ensure that a low-resistance earth connection is established.

10.4 Disposal

This test set, including all its accessories, is not intended for household use. At the end of its service life, do not dispose of the test set with household waste.

For customers in EU countries (incl. European Economic Area)

b2 electronics test sets are subject to the EU Waste Electrical and Electronic Equipment Directive (WEEE directive). As part of our legal obligations under this legislation, b2 electronics offers to take back the test set and to ensure that it is disposed of by authorized recycling agents.

For customers outside the European Economic Area

Contact the authorities in charge for the relevant environmental regulations in your country and dispose of the b2 electronics test set only in accordance with your local legal requirements.

Technical Support contact:
service@b2hv.com

b2 electronics GmbH

www.b2hv.com